

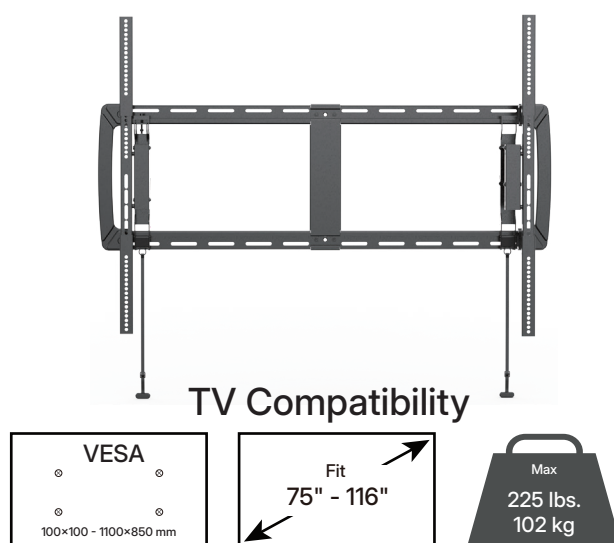

This modern ultra-large TV wall mount designed to accommodate TVs ranging from 75" to 116" with a robust weight capacity of up to 225 lbs. Its flexible VESA compatibility (100×100mm to 1150×850mm) ensures a perfect fit for a wide range of television models. This innovative wall mount features a modular panel design, allowing you to mount up to two TVs simultaneously when combining panels. With +/- 0.5" post-installation leveling adjustment. The mount also supports horizontal shift 7.5" (VESA: 600×400), so you can customize the positioning to suit your needs. Enjoy effortless installation and removal with its quick-lock mechanism, saving you time and hassle. The open wall plate design accommodates power outlets and low-voltage pass-through for clean cable management. Achieve your desired viewing angle with the mount's adjustable depth, ranging from 2.0" to 5.2" from the wall.

Features

- Fits TVs from 75" to 116" with VESA compatibility 100×100mm to 1150×850mm
- Supports up to 225 lbs for secure installation
- Post-install leveling adjustment +/- 0.5"
- Horizontal shift 7.5" (VESA: 600×400) for precise positioning
- Quick-lock structure for fast installation and removal
- Open panel design accommodates power outlets and low-voltage pass-through
- Adjustable depth: 2.0"–5.2" from the wall



Model Number: ERMLX1-01B

Warranty: 5-Year

Product Specifications	DIMENSIONS (L x W x H)	PRODUCT WEIGHT	LOAD CAPACITY	FINISH	AVAILABLE COLORS
	52.1"×34.6"×2.0"	21.3Lbs.	225Lbs.	Powder Coating	Black
	1323mm×880mm×51mm	9.68KG	102 KG		

Package Specifications	PACKAGE SIZE (L x W x H)	PACKAGE WEIGHT	PACKAGE UPC CODE	PACKAGE CONTENTS	UNITS IN PACKAGE
	30.2"×17.5"×3.2"	24.8Lbs.	810082201697	Product, Manual, Mountng Template, HDW Kits	1 Unit
768mm×445mm×82mm	11.23KG				

Master Carton Specifications	CARTON SIZE (L x W x H)	CARTON WEIGHT	CARTON BARCODE	CARTON CONTENTS	UNITS IN CARTON
	30.7"×18.4"×7.6"	52.2Lbs	10810082201696	Finished Goods	2 Units
780mm×466mm×193mm	23.68KG				

Product Dimensions

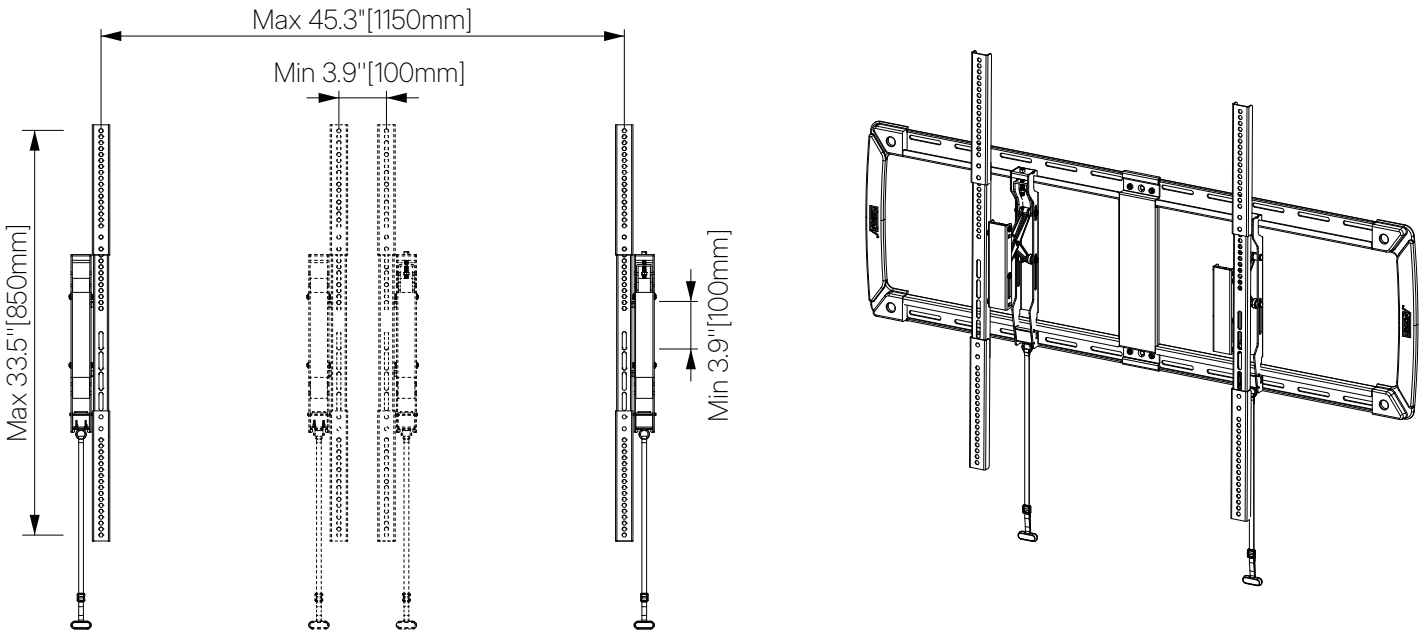

TV INTERFACE

3D VIEW

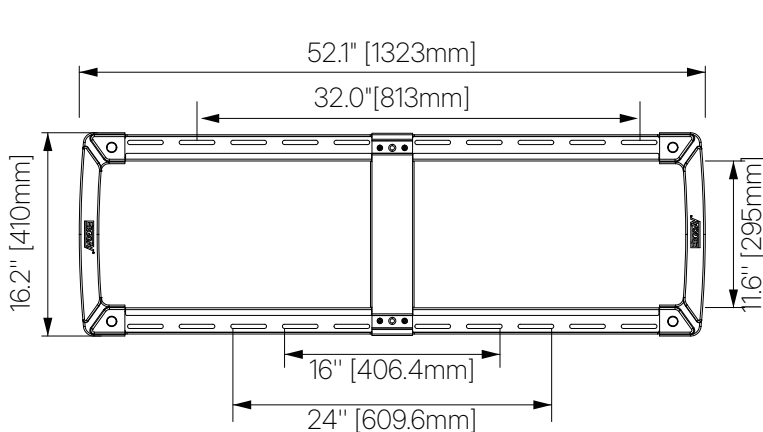

WALL PLATE

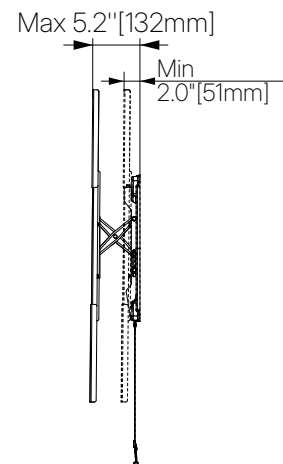

SIDE VIEW