



The ERMLM3-01B is a Medium Fixed TV Mount 19"-65" TV weighing 100 lbs of wood stud, concrete, and 80 lbs drywall. This mount has a profile of 1.7" and can be level-adjusted on one bracket. Easy three-step installation. A universal hardware bag is included in the package. The ERMLM3-01B locking mechanism is a spring lock block with magnetic adjustable cords, allowing them to be discreetly concealed in the TV, regardless of its size. ERMLM3 is UL-tested and certified.

### Features

- Fits 19"-65" TVs weighing 100 lbs of wood stud, concrete, and 80 lbs drywall.
- Low profile mount of 1.7".
- Level-adjusted on one bracket.
- Easy three-step installation.
- locking mechanism is a spring lock block with magnetic adjustable cords.
- UL-tested and certified.



### TV Compatibility

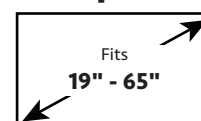
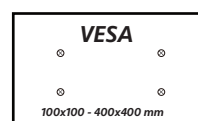

**WARRANTY:** 5-Year

Product Specifications	DIMENSIONS (W x H x D)	PRODUCT WEIGHT	LOAD CAPACITY	FINISH	AVAILABLE COLORS
	17.1" x 16.8" 1.7"	2.45lbs.	100lbs.	Powder Coating	Black
434mm x 426mm x 43mm	1.1 KG	45 kg			

## Product Dimensions

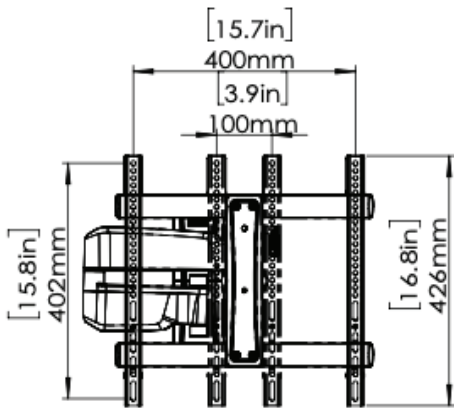

VESA: 100x100  
to 400x400

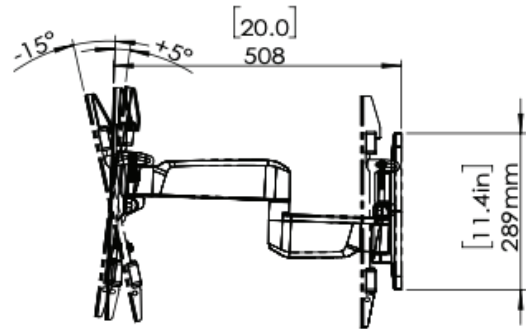

TV INTERFACE

SIDE VIEW - TILTING

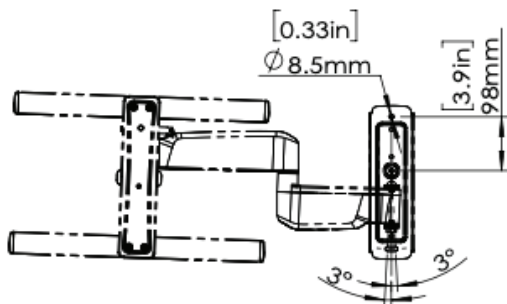

WALL PLATE

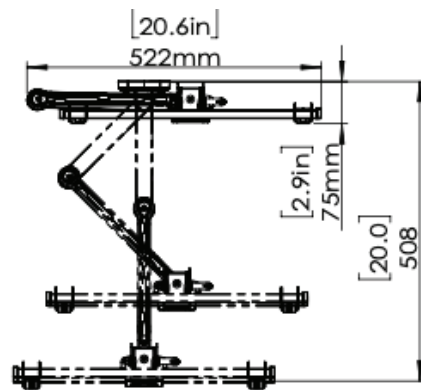

TOP VIEW