

Ship With View

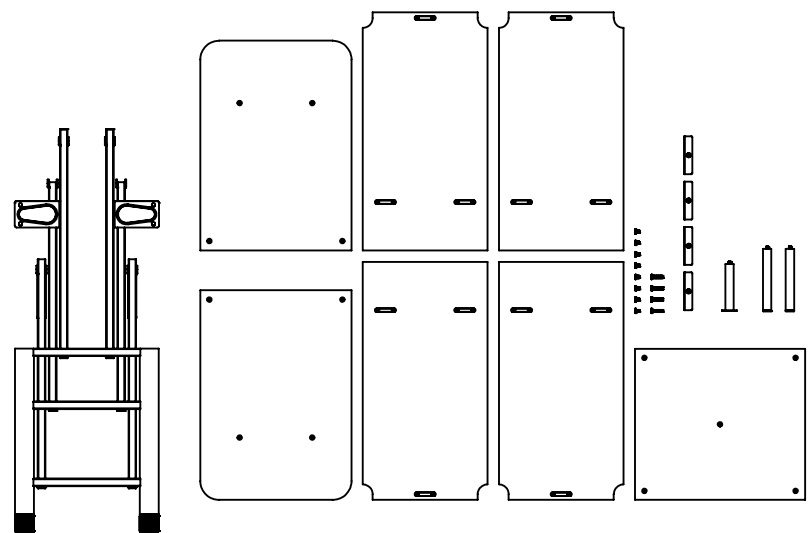

800-01596 REV00

Model Number	ERTFL1-01
Maximum Weight	300 LBS
Net Weight	59.88 LBS
Gross Weight	72.93 LBS
Product Dimension	61.42" x 15.75" x 19.68"
Packaging Dimension	46.85" x 17.32" x 10.27"

THE INFORMATION CONTAINED IN THIS DRAWING IS THE CONFIDENTIAL AND PROPERTY OF SHENZHEN BESTQI INNOVATION TECHNOLOGY CO.,LTD. ANY REPRODUCTION OR DISCLOSED WITHOUT THE WRITTEN PERMISSION OF BESTQI IS PROHIBITED.

3-D View (Capacity Weight)

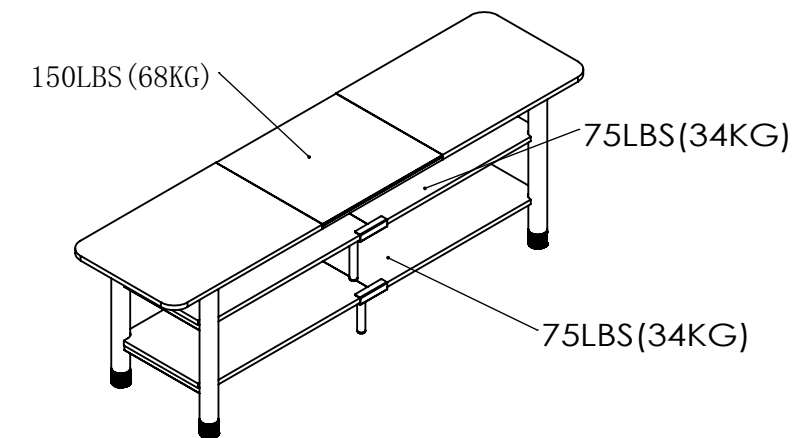

FRONT VIEW

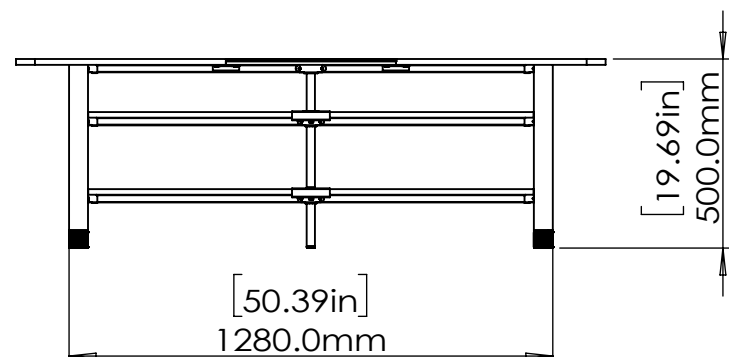

LEFT VIEW

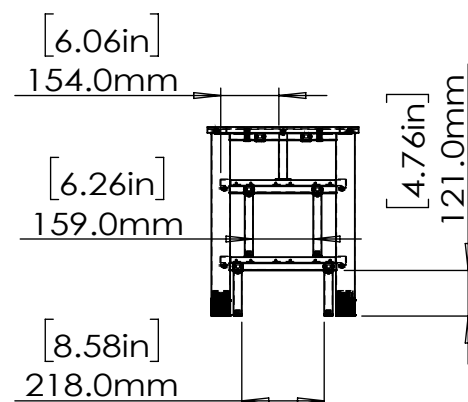

REAR VIEW

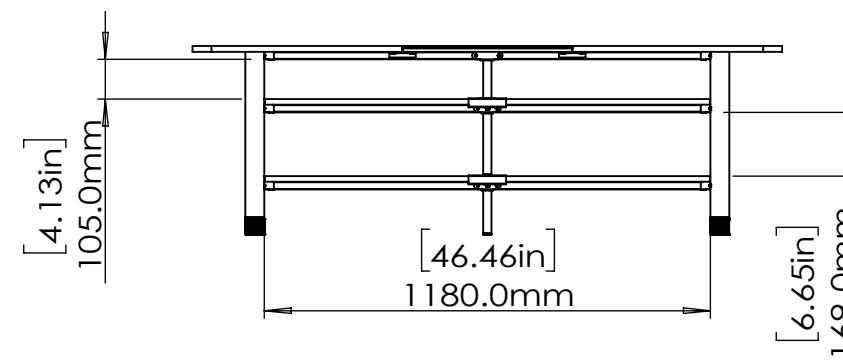

TOP VIEW

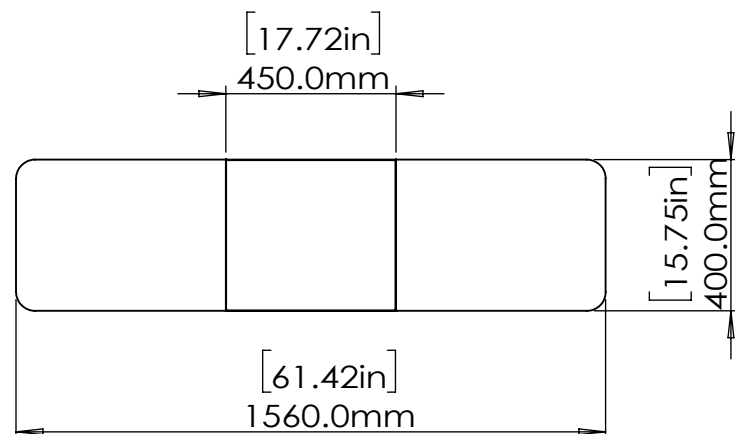

RIGHT VIEW

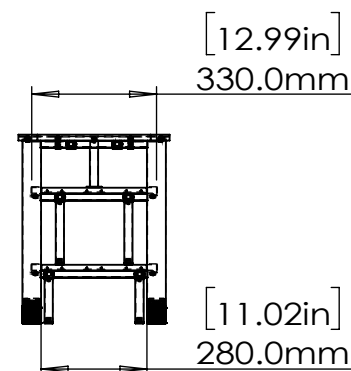

FUNCTION

