



# TV Cart Instruction Manual

(A)

English pages: 02–17

French pages: 18–33

Spanish pages: 34–49

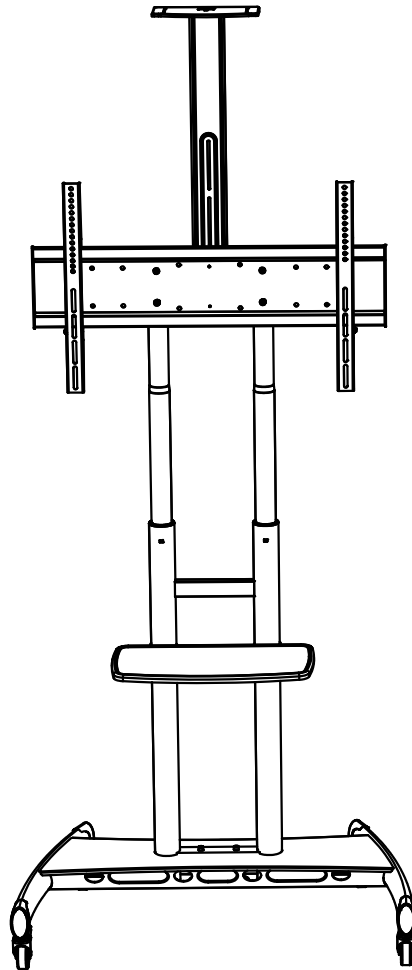

**Model: BETCXL1-01B**

## Thank You for Choosing this ErgoAV Product!

At ErgoAV, we want to add value to your AV experience by providing the highest quality products and services in the industry. If you have any concerns or comments, please contact us.

**ErgoAV Customer Care**

phone (877) 419-7832

email: [support@ergoav.com](mailto:support@ergoav.com)

website: [www.ergoav.com](http://www.ergoav.com)

address: 9501 Louisiana Ave N, #200, Brooklyn Park, MN 55445

## IMPORTANT SAFETY INFORMATION

**⚠ DANGER!** Please carefully read all instructions before attempting installation. If you do not understand the instructions or have any concerns or questions, please contact Technical Support at (877) 419-7832 or Customer Service at support@ergoav.com.

**⚠ CAUTION:** Use with products heavier than the maximum weights indicated may result in instability causing possible injury.

- Do not use this product for any purpose that is not explicitly specified in this manual.
- Use this mounting system only for its intended use as described in these instructions. Do not use additional attachments not recommended by the manufacturer.
- Do not use outdoors. This product is intended for indoor use only.
- Do not exceed any weight capacity listed in the manual for this product. Overloading audio and / or video carts with additional equipment not in specified locations, may result in death or serious injury due to the cart collapsing, instability during movement, or tipping over.
- Route cords and cables properly to avoid mechanical damage and possible trip hazards.
- Additional care should always be taken when using carts around children. Interesting objects, like a remote control or toy, placed or stored on the cart could encourage a child to climb on the cart and cause the cart to tip over. Death or serious injury may occur when children climb on audio and / or video equipment carts.
- We are not liable for damage or injury caused by improper mounting, incorrect assembly, or inappropriate use.
- SAVE THESE INSTRUCTIONS.

Before starting assembly, verify all parts are included and undamaged. Do not use damaged or defective parts. If you need replacement parts, please contact Technical Support at (877) 419-7832 or Customer Service at support@ergoav.com.

## Check the VESA Pattern of Your TV before the Installation

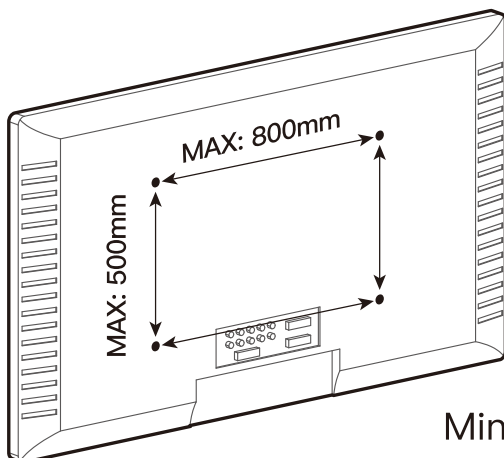

200mm	≈ 7 7/8"
300mm	≈ 11 3/4"
400mm	≈ 15 3/4"
500mm	≈ 19 11/16"
600mm	≈ 23 5/8"
700mm	≈ 27 9/16"
800mm	≈ 31 1/2"

Minimum: 200mm x 200mm / 7 7/8" x 7 7/8" (W x H)

Maximum: 800mm x 500mm / 31 1/2" x 19 11/16" (W x H)

If your TV's VESA Pattern is smaller than 200mm x 200mm or greater than 800mm x 500mm, this mount is NOT COMPATIBLE with your TV. Please contact Technical Support at (877) 419-7832 or support@ergoav.com to find a compatible mount.

# Weight Restrictions



**Top Tray Maximum Weight**  
Capacity: 10 lbs. (4.5 kg)



**TV Maximum Weight**  
Capacity: 200 lbs. (90 kg)



**Shelf Maximum Weight**  
Capacity: 10 lbs. (4.5 kg)



**MAX**  
TV mount  
200 lbs / 90 kg



**MAX**  
Shelf  
10 lbs / 4.5 kg



**MAX**  
Top Tray  
10 lbs / 4.5 kg

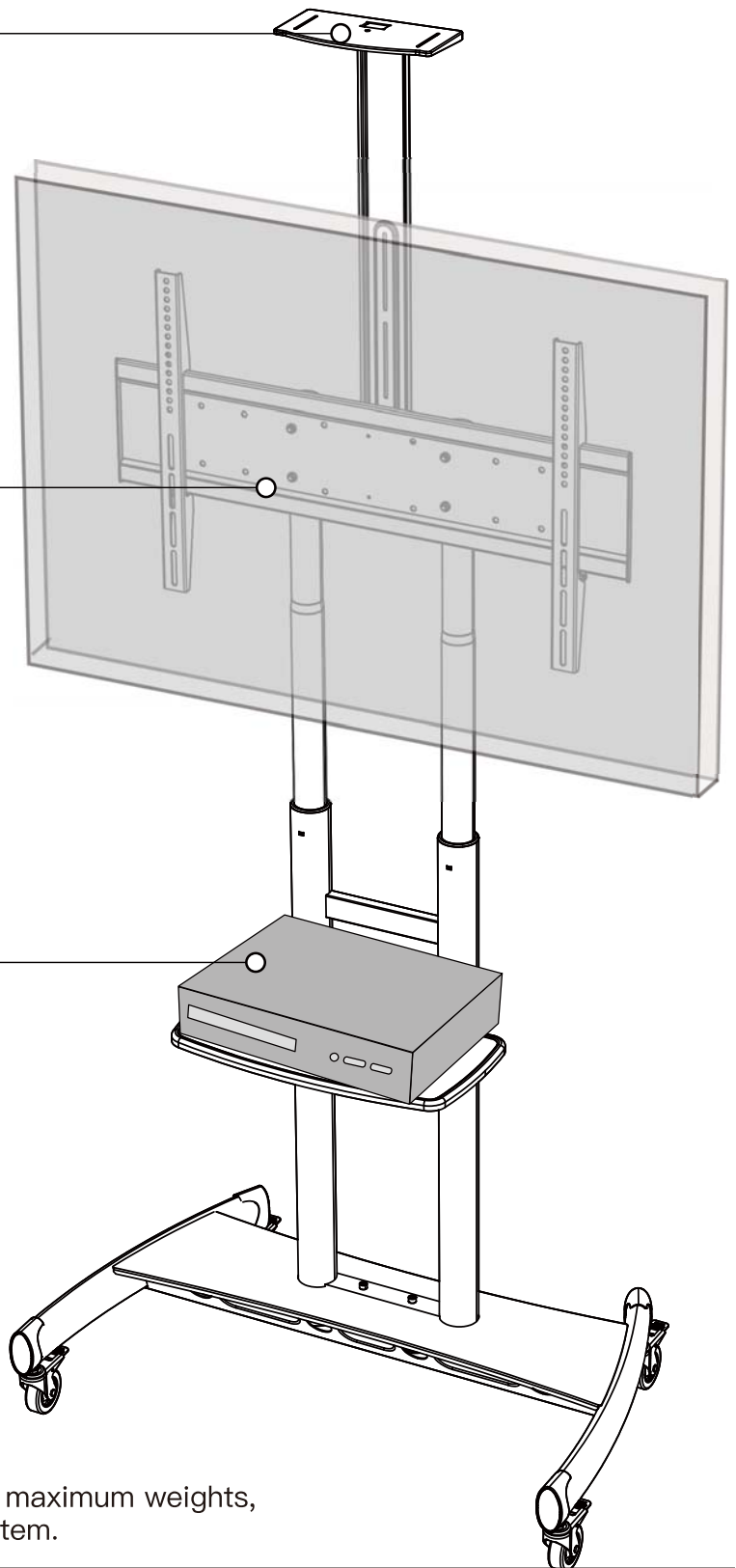

**!** If your products weigh more than the listed maximum weights, this TV cart is not compatible with your system.

## **!** WARNING

DO NOT exceed the maximum weight indicated. This mounting system is intended for use only within the weight range listed. Use with products heavier than the maximum weight limits may result in failure of the mounting system, causing potential damage and / or injury.

## Tools Needed (Not Included)



## Supplied Parts and Hardware for Step 1

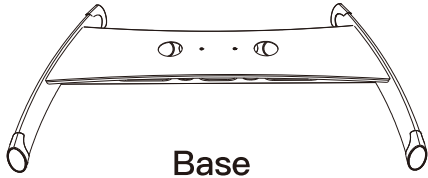

Base

**01** x 1



Caster

**02** x 4

## Step 1 Attach Casters to Base

1-1 Turn the Base [01] over so that the bottom of the Base [01] is in the up position.

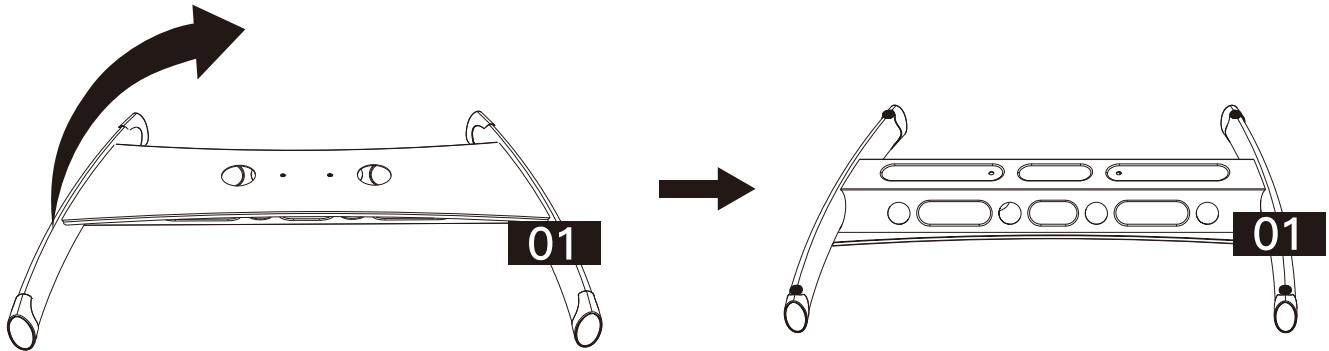

1-2. Position the Lock Tab downwards to lock the Caster [02]. Screw the Casters [02] into the Base [01] and tighten with self-supplied wrench.

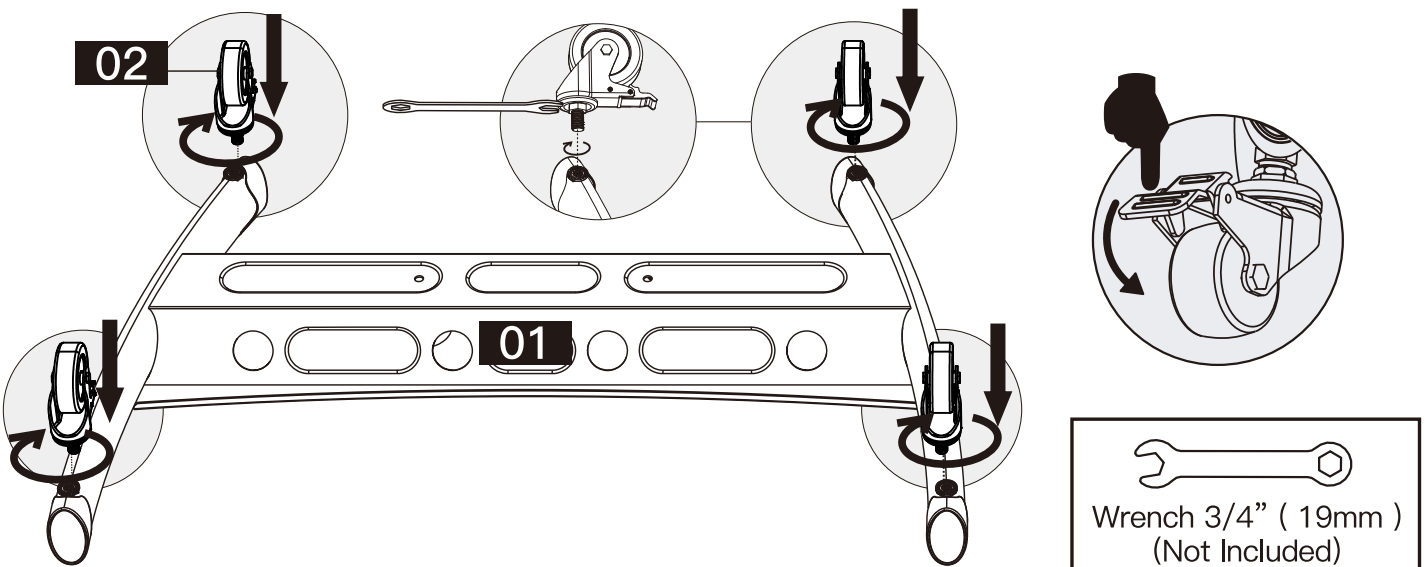

**NOTE:** To avoid movement of the Casters [02] while assembling, please lock the Casters [02].

Unlock

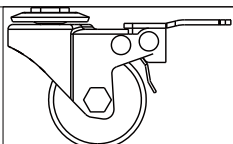

Lock

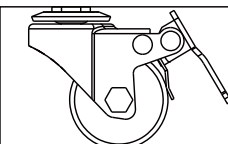



## Supplied Parts and Hardware for Step 2

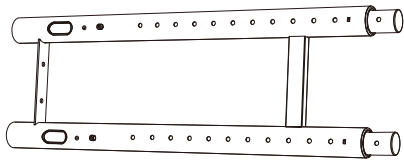

Height Adjustable Post

**03** x 1



Bolt  
M8 X 20mm  
A2 x 4



Allen Key  
M6  
E2 x 1

## Step 2 Connect Post Assembly to Base

2-1 Insert Height Adjustable Post [03] into the Base [01] as shown below. Insert two Bolts [A2] through the Height Adjustable Post [03] into the Base [01].

2-2 Insert remaining two Bolts [A2] up through Base [01] and into the threaded inserts in the bottom of the Height Adjustable Post [03]. Tighten all four Bolts [A2] with Allen Key [E2] until tight.

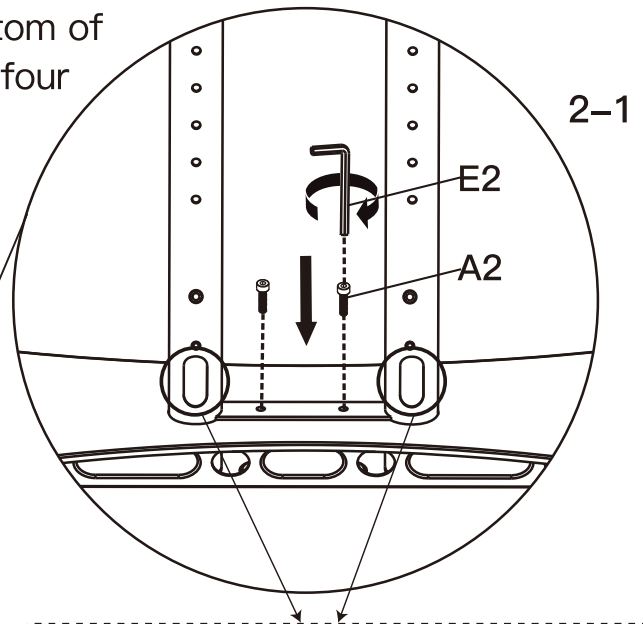
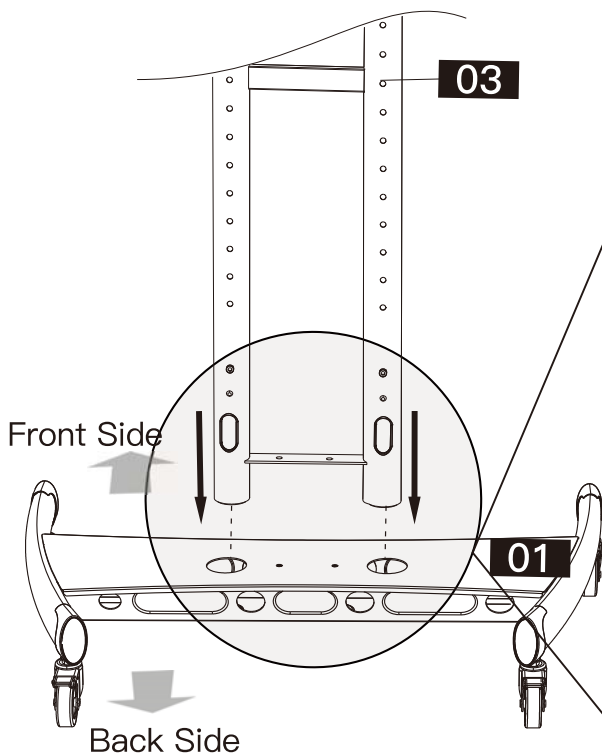

**Note:** Make sure cables management windows are facing the back of the base.

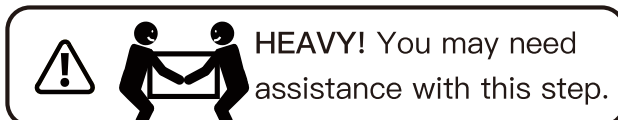
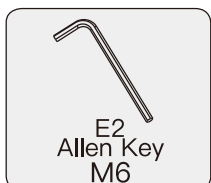
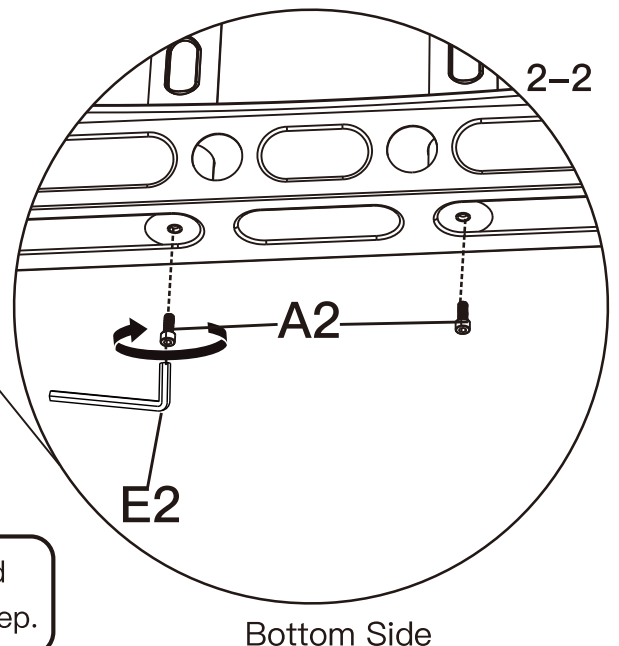

## Step 3 Adjust the Height of the Post

3-1 (Fig. 1) Unscrew pre-assembled Safety Bolt [S2] on Right Lower Poles Assembly using Allen Key [E2] and keep it for the use of step 3-4.

3-2 (Fig. 2) Use left hand thumb or index finger to depress Spring Ball [S1] located at the right lower post (Near cable window), at the same time use right hand to twist and pull right upper post (Clockwise or anti-clockwise) upwards to your desired height.

3-3 (Fig. 3) Use height label indicator on pole as guide. Then twist Upper Pole toward plunger holes direction and engaged Spring Ball [S1] into the plunger hole.

3-4 (Fig. 4) Secure Safety Bolt [S2] firmly using Allen Key [E2].

NOTE: Please do the procedures from step 3-1 to 3-4 to pull out the left upper post.

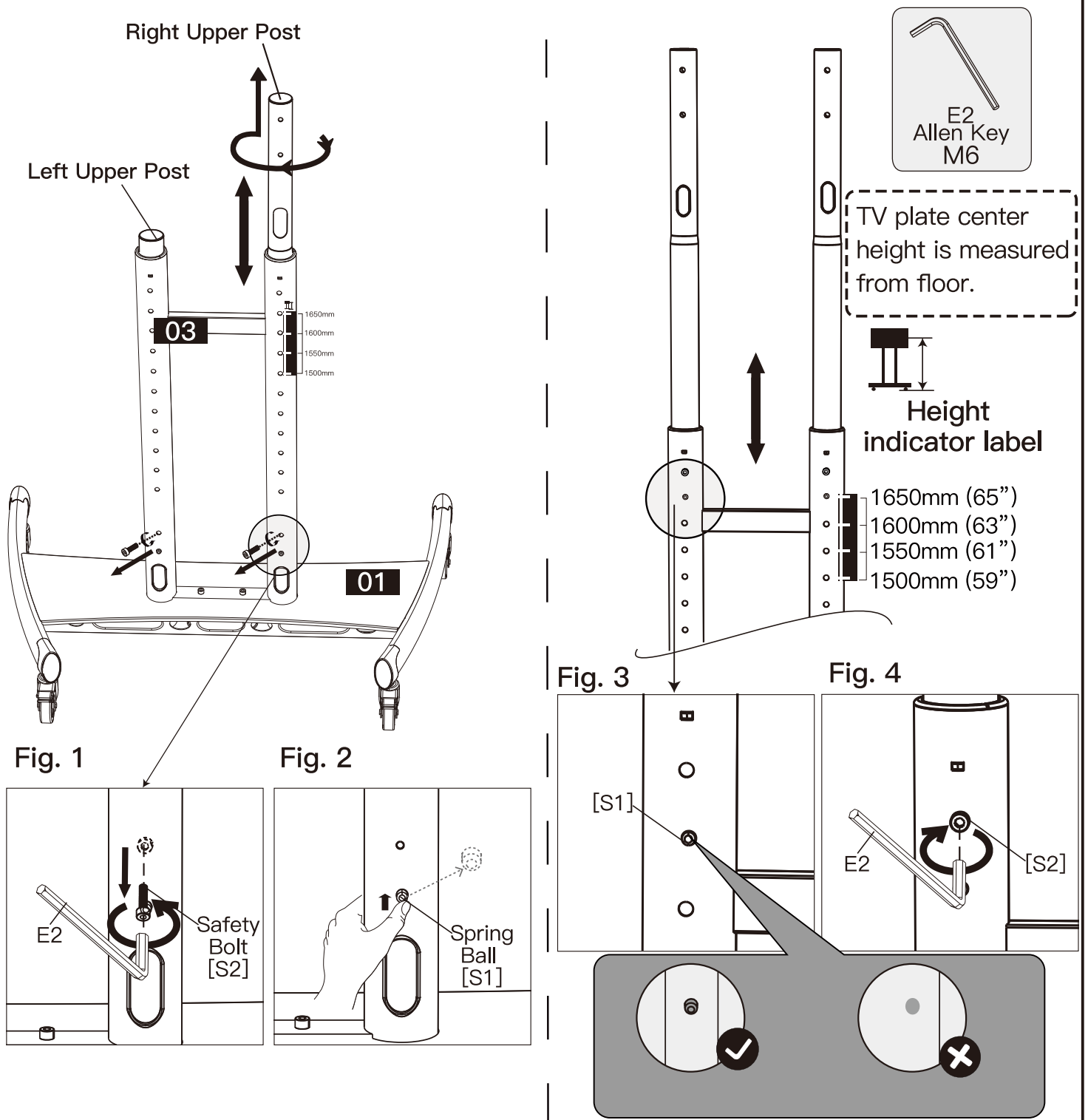

# Supplied Parts and Hardware for Step 4



Cable Cover

**04** x 2

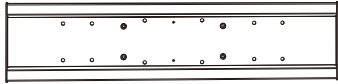

TV Plate

**05** x 1

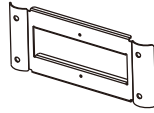

Connecting Plate

**06** x 1



Bolt  
M8 X 72mm  
B2 x 4



Spacer  
L13mm  
D2 x 4



Allen Key  
M6  
E2 x 1

## Step 4 Secure the Connecting Plate and TV Plate on Height Adjustable Post



Attach the Cable Covers [04]. Insert Bolts [B2] through Connecting Plate [06], Upper Poles, Spacers [D2] and TV Plate [05]. Tighten with Allen Key [E2] until secure.



4-2

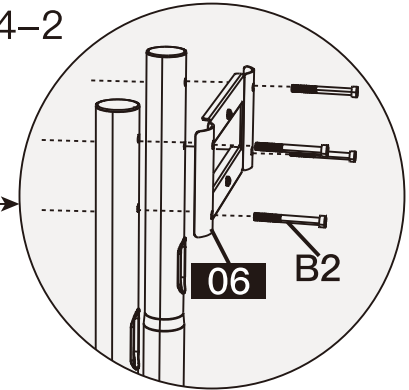

4-3

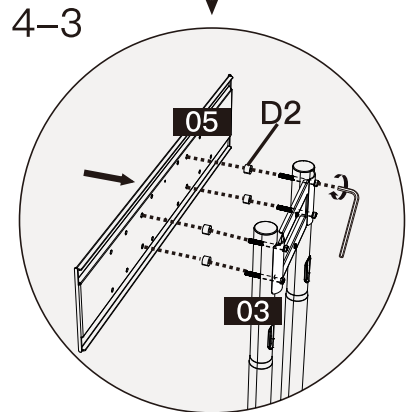

4-4

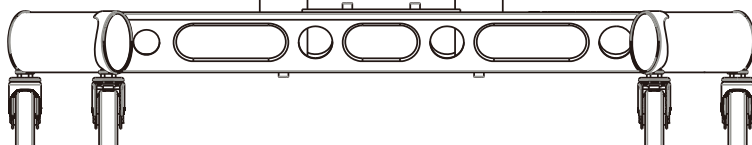
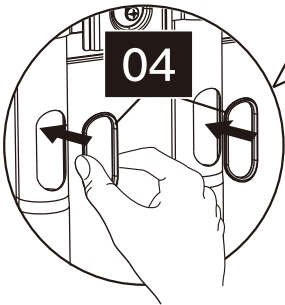
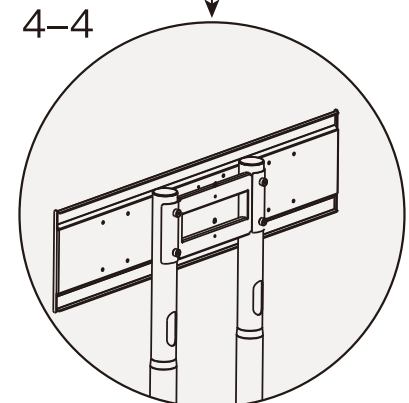

# Supplied Parts and Hardware for Step 5

NOTE: The washers and spaces shown are actual size.

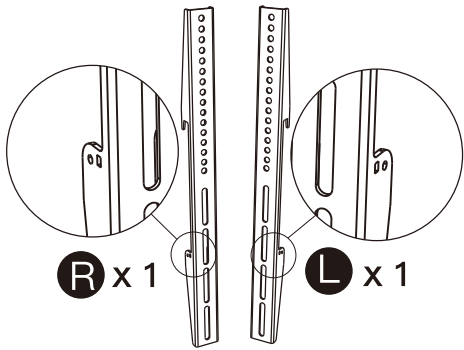

**R** x 1      **L** x 1

TV Brackets

**07**

## Washers



M4 / M6  
H1 x 4



M8  
H2 x 4

## Spacers [if needed]

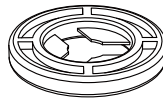

L2.5mm  
I x 8

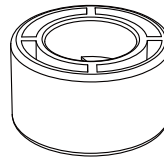

L10mm  
J x 4

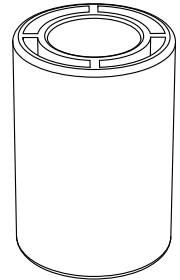

L23mm  
K x 4

## TV Bolts

[Only one size bolt fits your TV]

Note: The bolts shown are actual size.

**M4**



M4 x 30mm  
[A] x 4

**M6**

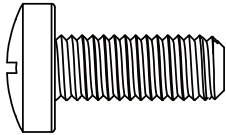

M6 x 16mm  
[B] x 4

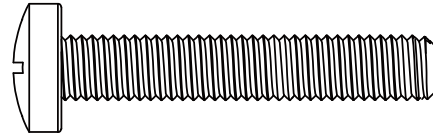

M6 x 35mm  
[C] x 4

**M8**

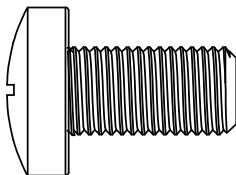

M8 x 15mm  
[D] x 4

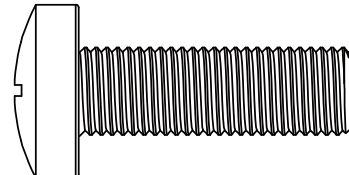

M8 x 25mm  
[E] x 4

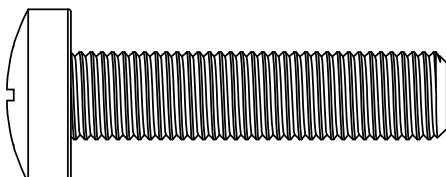

M8 x 35mm  
[F] x 4

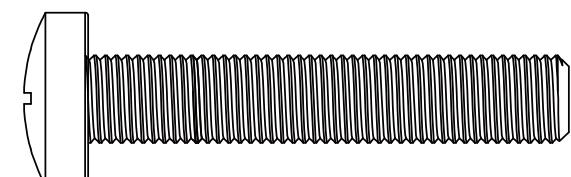

M8 x 50mm  
[G] x 4

# Step 5 Attach the TV Brackets to the TV

## Select TV Bolts

Only one size bolt fits your TV.

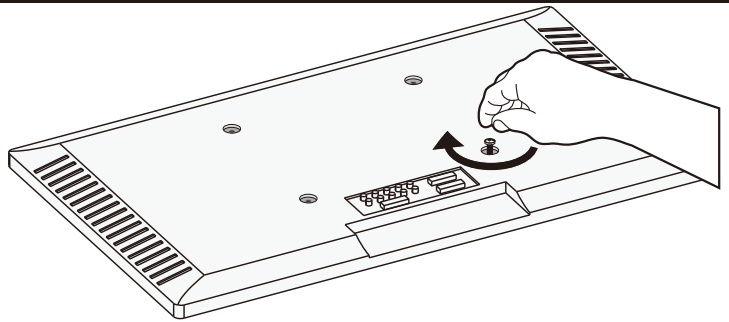
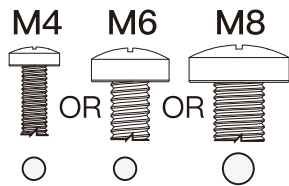

**Bolt length:** Verify adequate thread engagement with bolts or bolts / spacers combination. We recommend thread engagement of at least 5 turns.

–Too short will not hold the TV.

–Too long will damage the TV.

**NOTE:** Please do not over tighten the TV bolts to avoid damaging your TV.

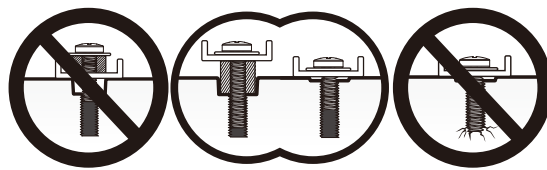

Too short

Correct

Too long

**NOTE:** If spacers are required for your installation, a combination of different spacers can be stacked to obtain a proper length. See examples in the image below. If you have any difficulty understanding how to install the TV bolts or spacers, please contact Technical Support at (877) 419-7832 or Customer Service at [support@ergoav.com](mailto:support@ergoav.com).

## Parts Needed if You Have a TV as Shown Below

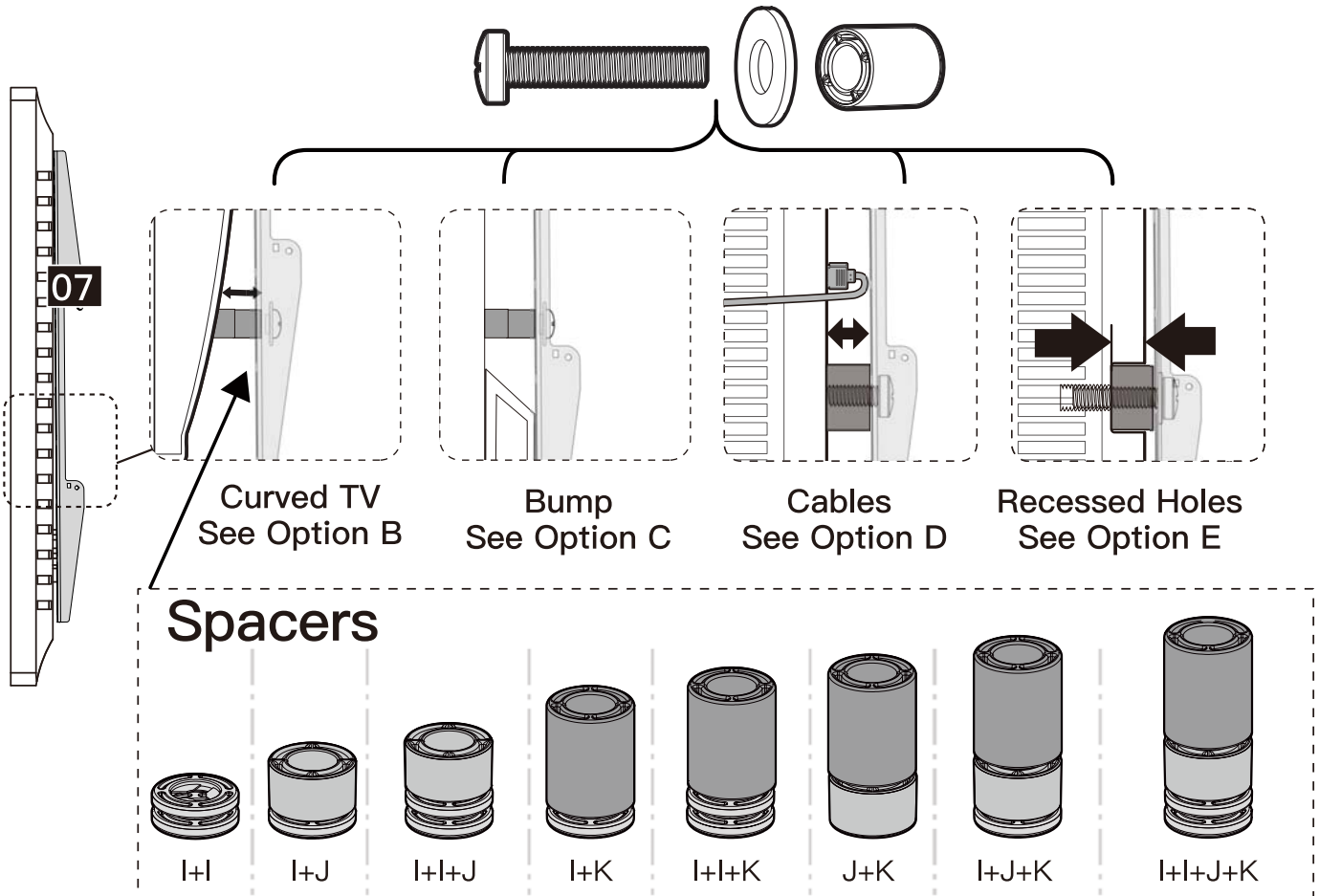

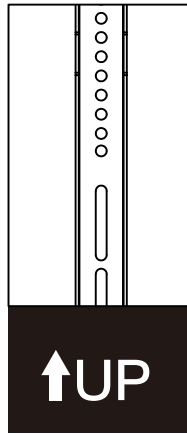
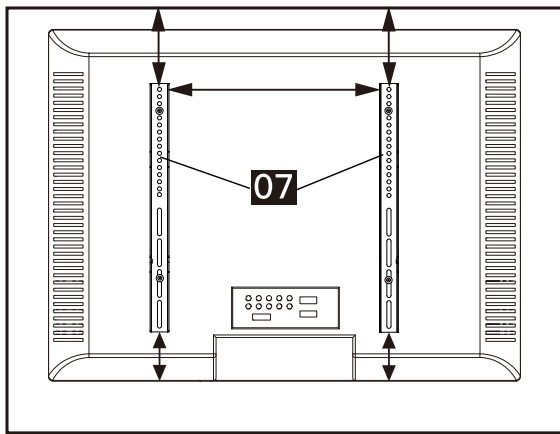

**⚠ CAUTION:** When attaching the TV Brackets [07] to the back of the TV, ensure the ends with the rounded holes are pointing towards the top of the TV and equally centered on the back of the TV.

**⚠ NOTE:** The bolt hole locations on your TV may vary in accordance of the manufacturer's design of the TV. We are only illustrating possible locations of the bolt holes.

### Option A (For Flat Back TV)

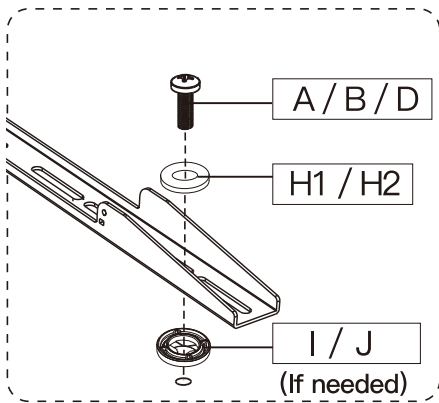

Refer Back to Spacer Instructions on Page 09, If Needed

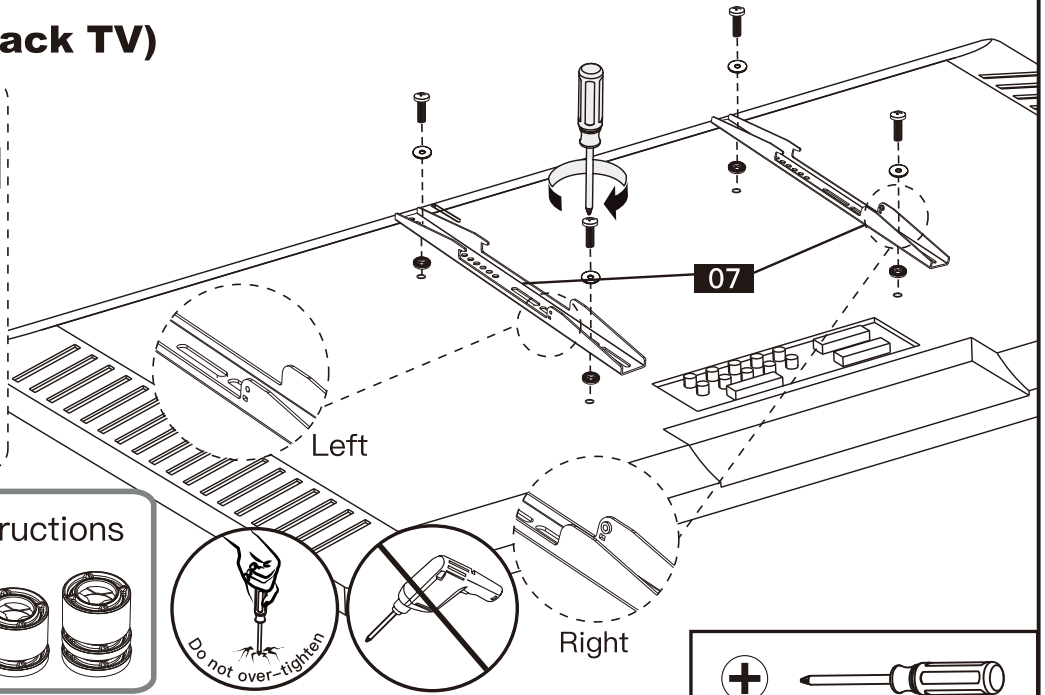

### Option B (For Curved Back TV)

The Spacers must be tall enough so that the curve on the back of the TV will not interfere with the mounting plate.

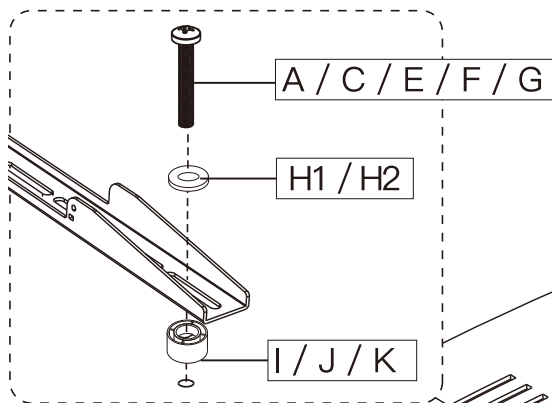

Refer Back to Spacer Instructions on Page 09, If Needed

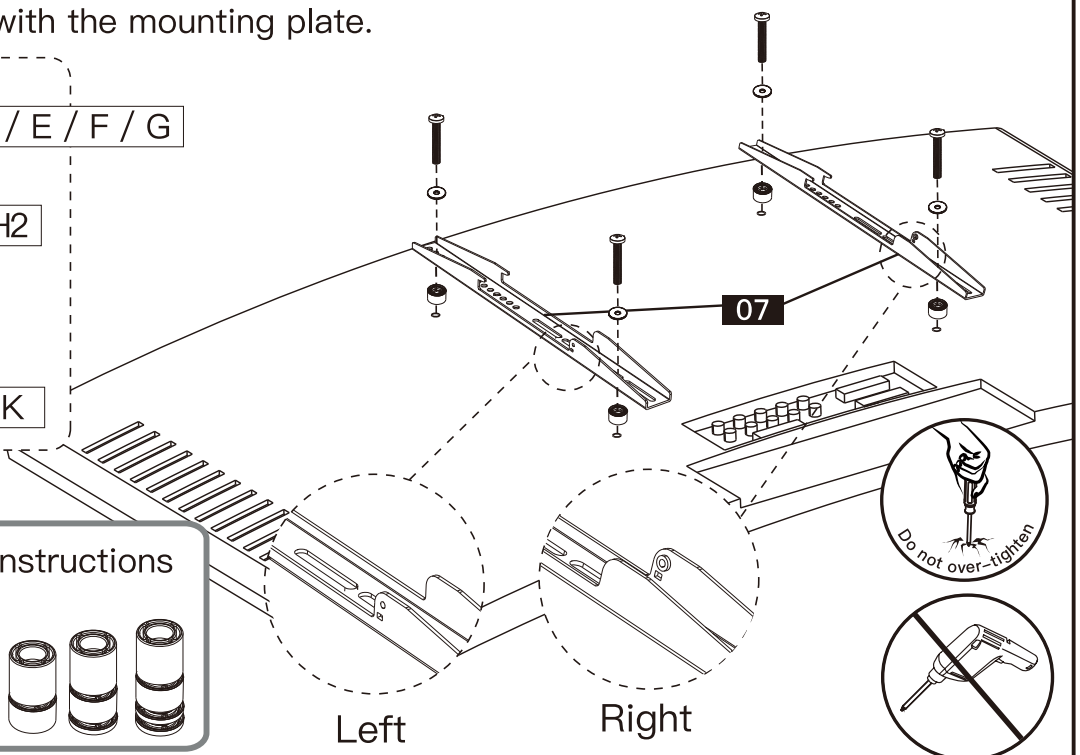



### Option C (For TV with A “Bump”)

The spacers must be tall enough so there is no gap between TV brackets and bump on the back of the TV.

 Phillips Screwdriver  
(Not Included)

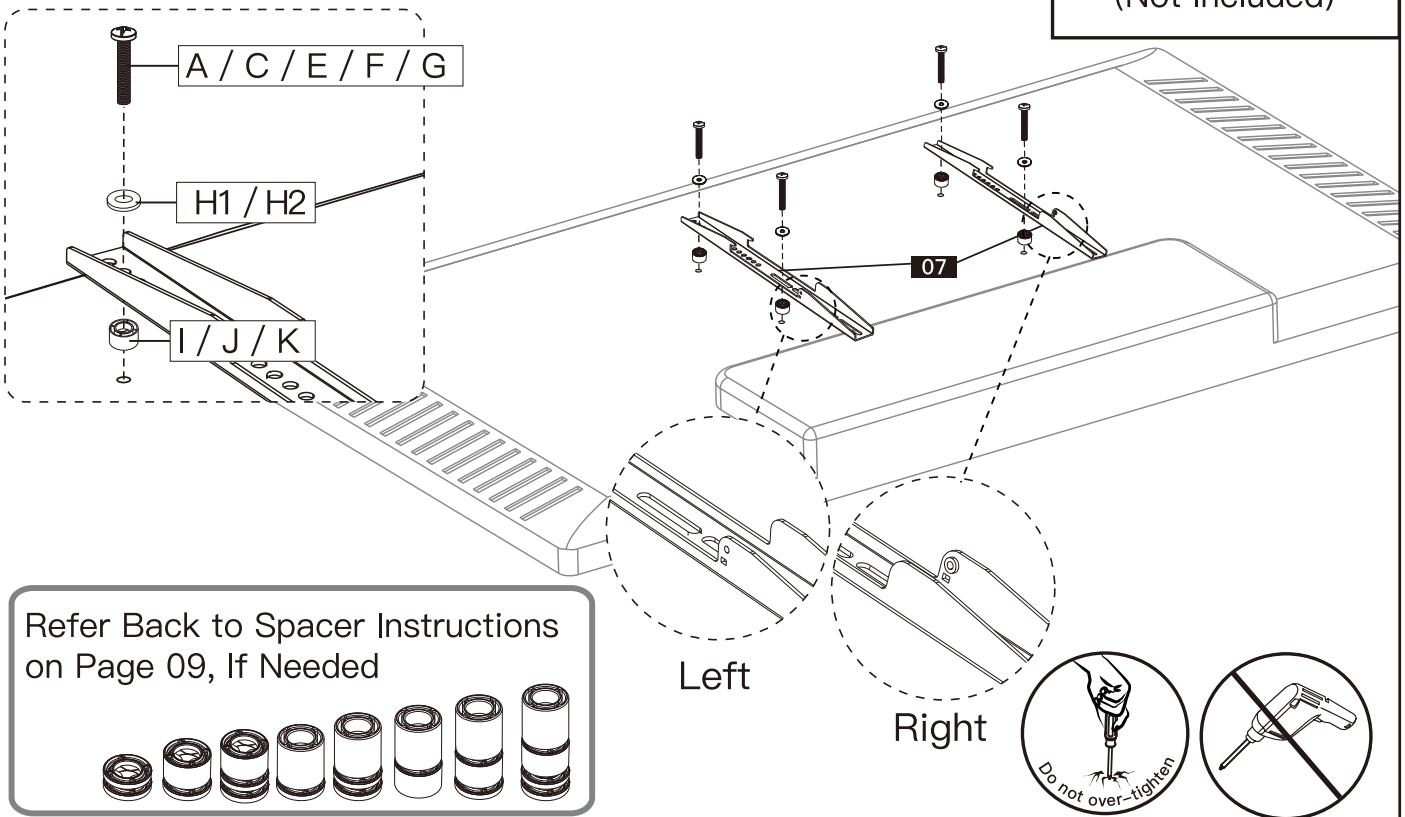

Refer Back to Spacer Instructions on Page 09, If Needed

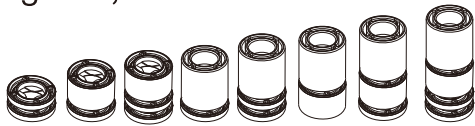

### Option D (For TV with Cable Interference)

For cable interference, use Spacers [I], [J] and [K] to create extra space between the TV and TV brackets.

 Phillips Screwdriver  
(Not Included)

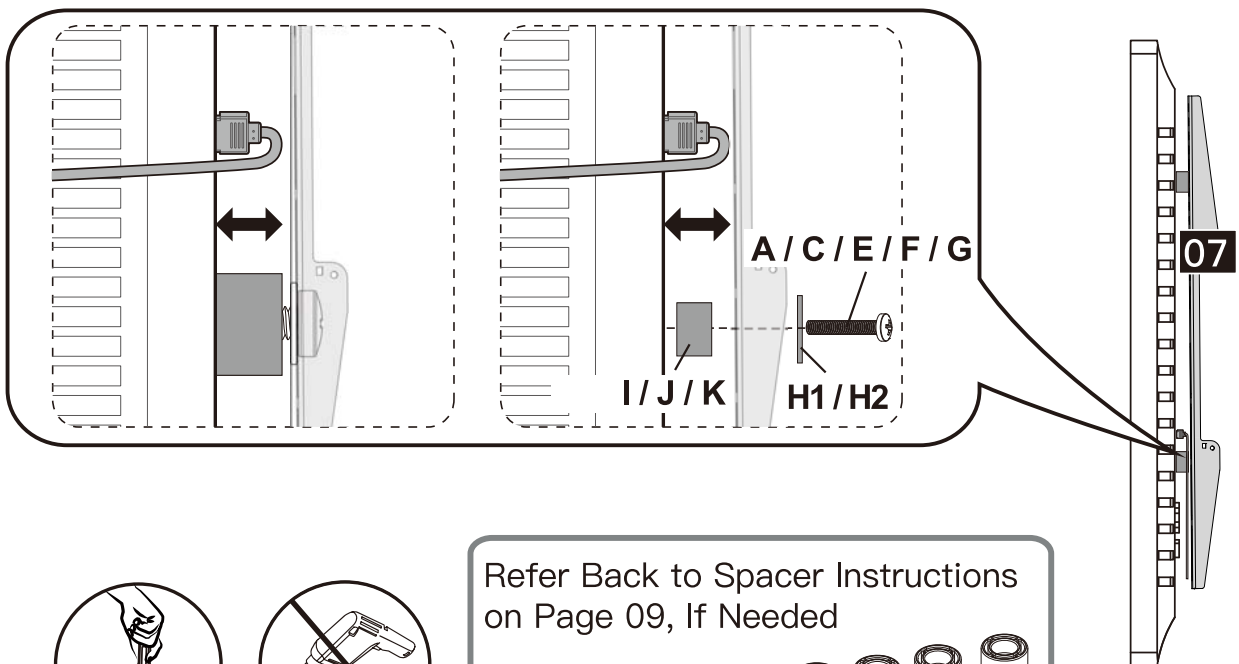

Refer Back to Spacer Instructions on Page 09, If Needed





### Option E (For Recessed Holes )

The Spacers [I], [J] and [K] need to fill in the recessed holes on the basis of the TV so that the TV brackets are as close to the TV as possible.

 Phillips Screwdriver  
(Not Included)

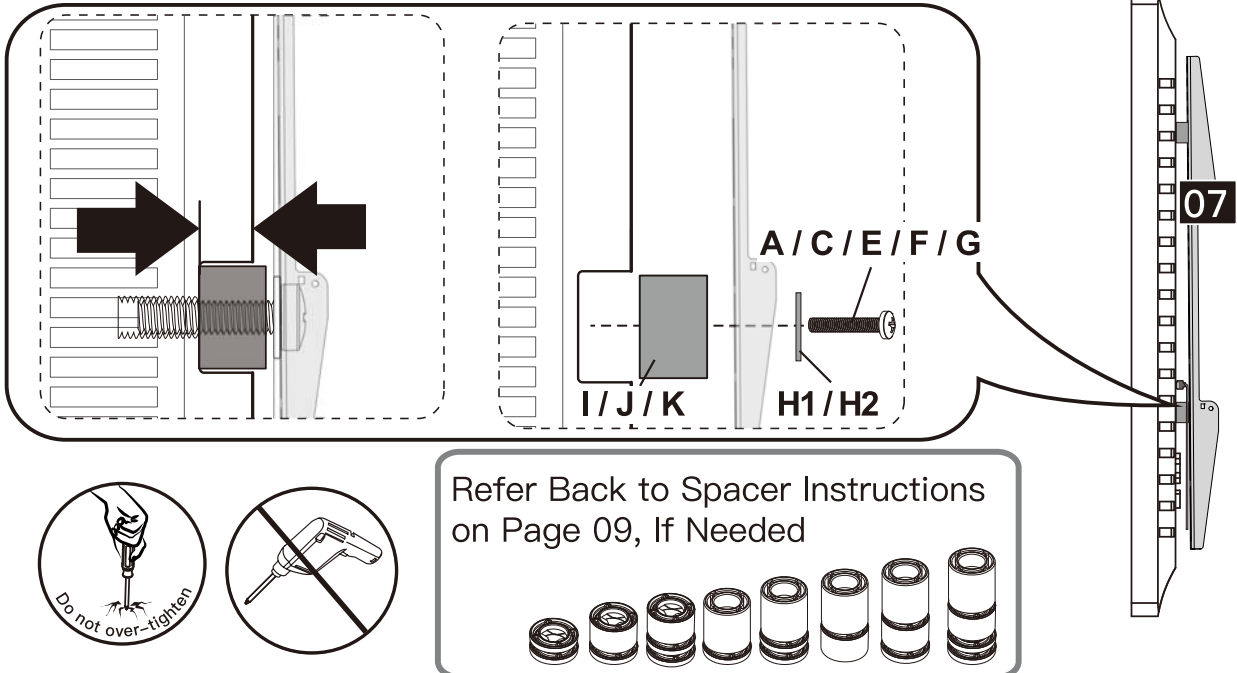

### Supplied Parts and Hardware for Step 6

-  **R** x1
-  **L** x1
- Safety Lock  
**F2**
-  Bolt  
**M5x12mm**  
**G2 x 2**

### Step 6 Hang the TV to TV Plate

6-1 Hang the TV with TV Brackets [07] onto the TV Plate [05].

**NOTE:** TV should be hung in the center of the TV Plate [05] to keep balance.

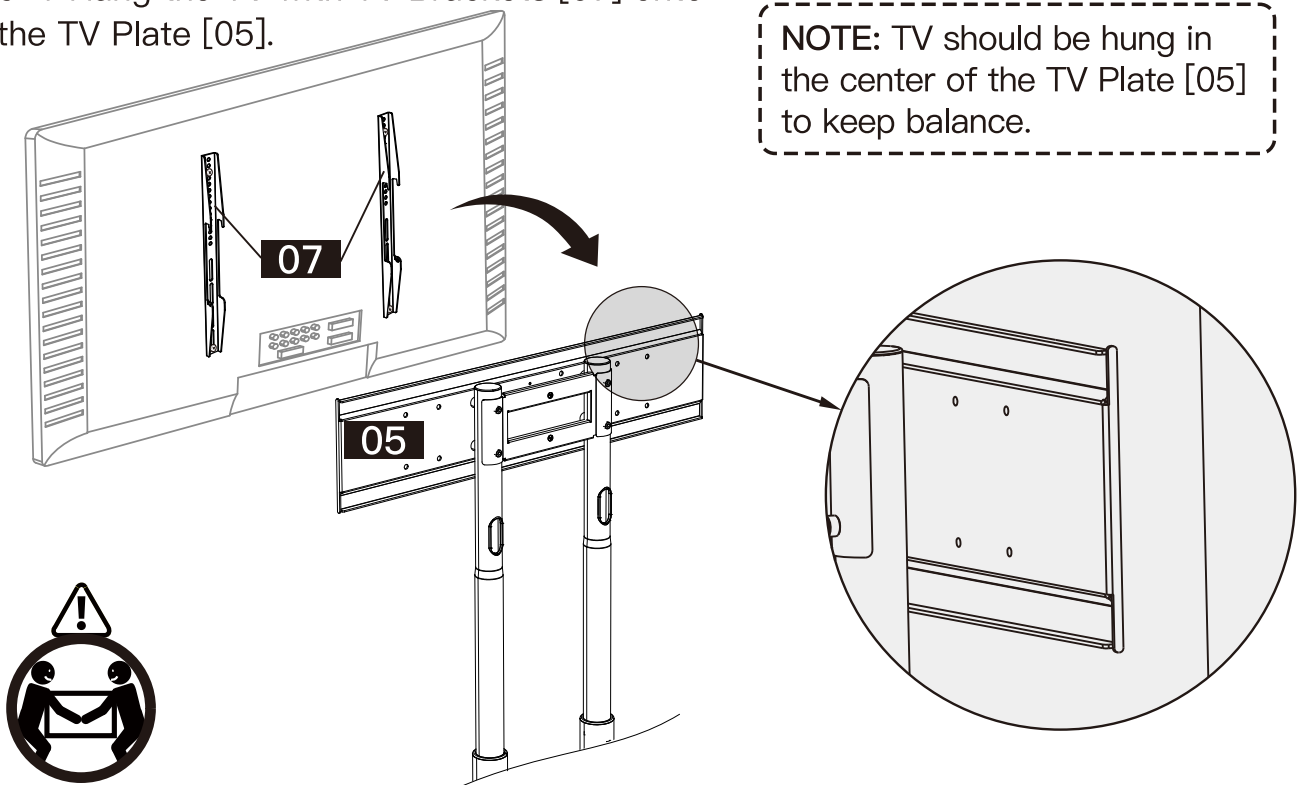

6-2 Insert Bolts [G2] through Safety Locks [F2] and thread into TV Brackets [07]. Tighten with Phillips Screwdriver.

**NOTE:**  
Move TV to center.

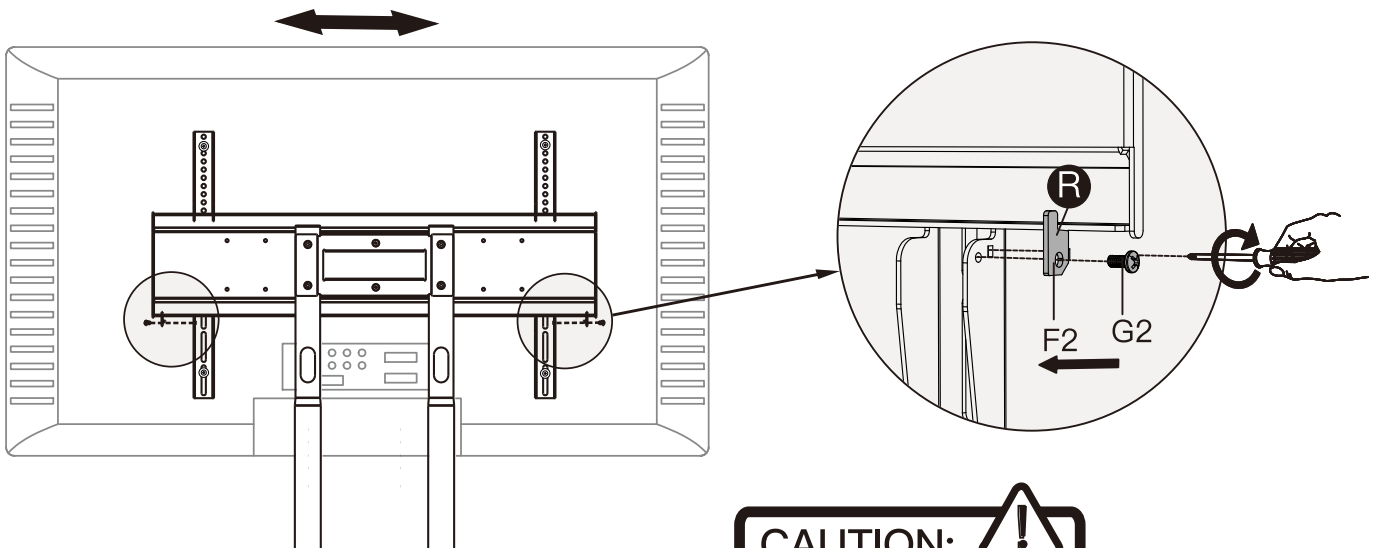

 Phillips Screwdriver  
(Not Included)

**CAUTION:**   
Ensure bolts are secured firmly.

## Supplied Parts and Hardware for Step 7

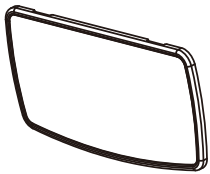

AV Shelf  
**08** x 1

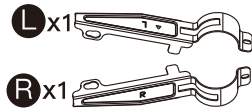

AV Shelf Supports  
**09**

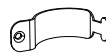

Ring  
**10** x 2



Bolt  
M8 X 20mm  
**A2** x 2



Allen Key  
M6  
**E2** x 1

## Step 7 Attach AV Tray to the Height Adjustable Post

**7-1-1**

Align the holes in the shelf Supports [09] with the bumps on the bottom of the AV Shelf [08].

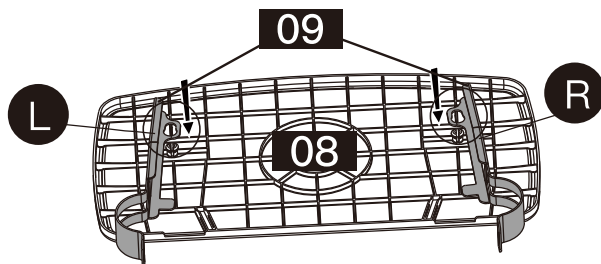

**7-1-2**

Pull the Shelf Support [09] towards the back of the AV Shelf [08] until the Shelf Support [09] is locked onto the Bump on the AV Shelf [08]. Move the ends of each Shelf Support [09] towards the center until the tabs on the AV Shelf Supports [09] are fully inserted into the slots on the AV Shelf [08].

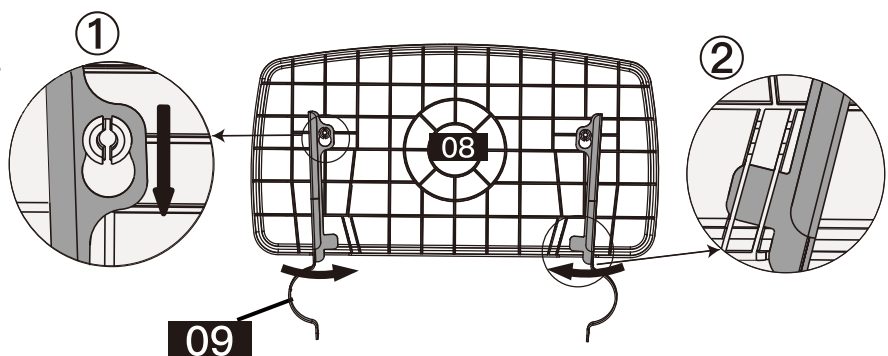

**7-1-3**

Attach a Ring [10] to each of the AV Shelf Supports [09].

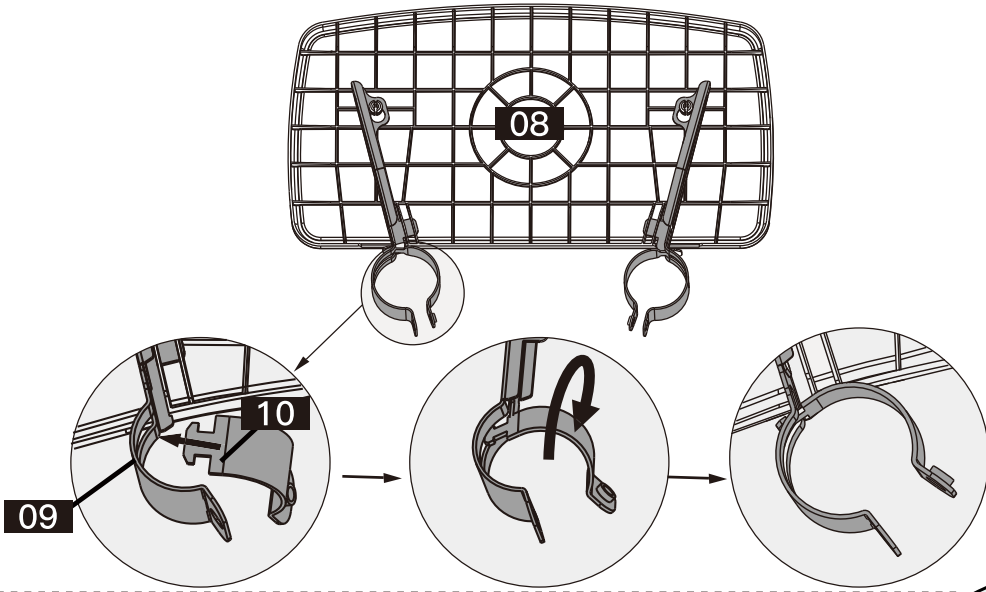

**7-2-1**

Attach the AV Shelf Assembly to the Height Adjustable Post [03].

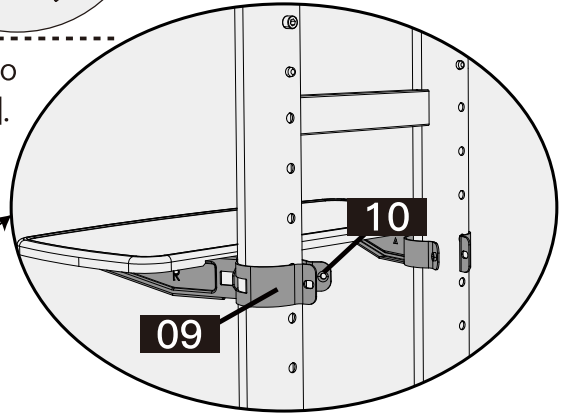
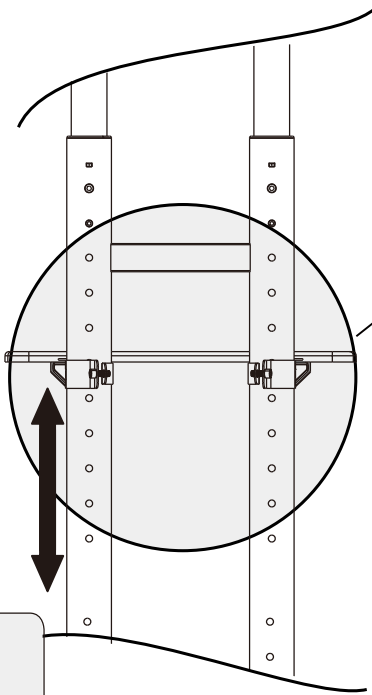

**7-2-2**

Secure the AV Shelf Assembly to the Height Adjustable Post [03] by fastening the Bolts [A2] using Allen Key [E2].

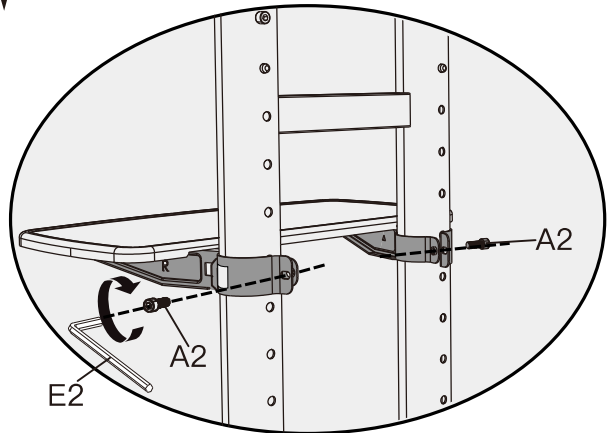

**Supplied Parts and Hardware for Step 8-9**



Video Tray Bracket

**11** x 1



Video Tray

**12** x 1



Bolt  
M5 x 10mm

**C2** x 1

## Step 8 Install the Video Tray Bracket on the Connecting Plate

8-1 Secure the Video Tray [12] on the top of Video Tray Bracket [11] using the Bolt [C2].

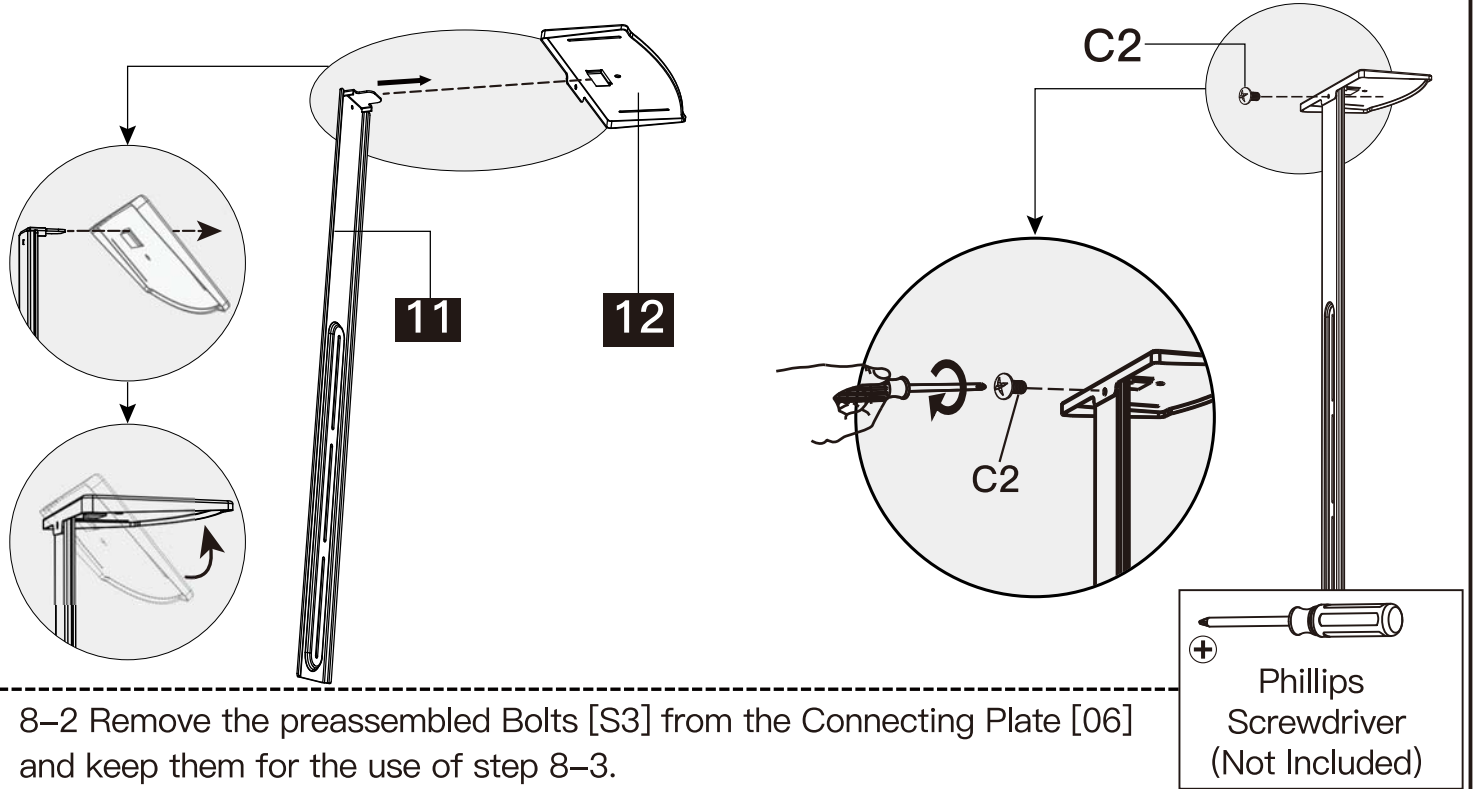

8-2 Remove the preassembled Bolts [S3] from the Connecting Plate [06] and keep them for the use of step 8-3.

8-3 Attach the the Video Tray Bracket [11] on the Connecting Plate [06] and tighten with the preassembled Bolts [S3].

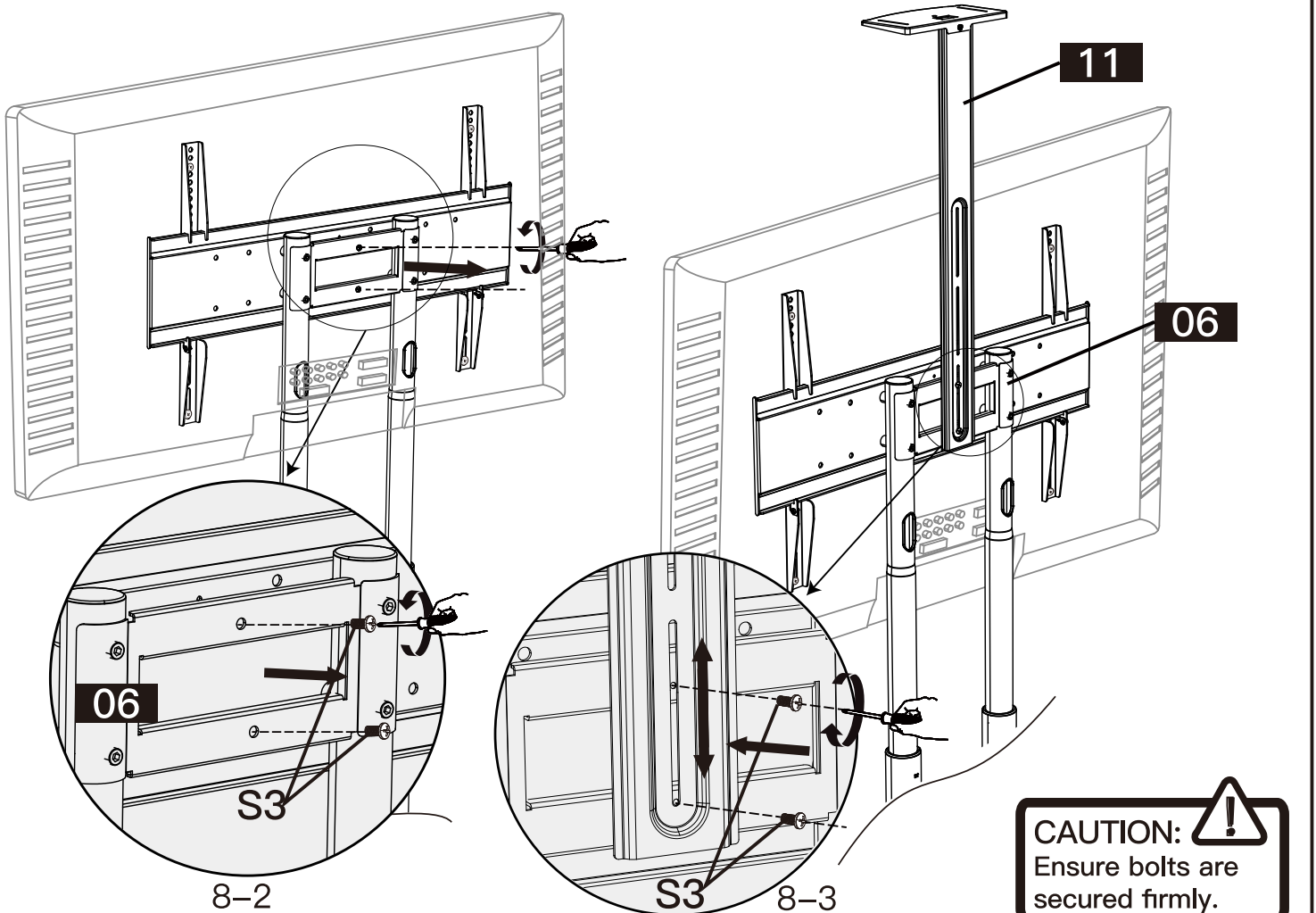

## Step 9 TV Height Adjustment and Cables Management (Optional)

**⚠ WARNING:** Adjusting the TV's height position while the TV is connected to the TV Cart can result in personal injury and / or property damage. Even with more than 1 person, never attempt to adjust the height of the TV while the TV is connected to the TV Cart.

If it is determined the height of the TV needs to be adjusted, it can be adjusted by following the steps listed below.

9-1 (Fig. 1) Remove all cables from the TV and disconnect the TV's power cord.

9-2 (Fig. 2) Remove Bolt [G2] and Safety Locks [F2] from the side of the TV Brackets [07].

9-3 (Fig. 3) Carefully remove the TV with TV Brackets [07] from the TV Plate [05]. Place the TV in a safe area that is out of the way.

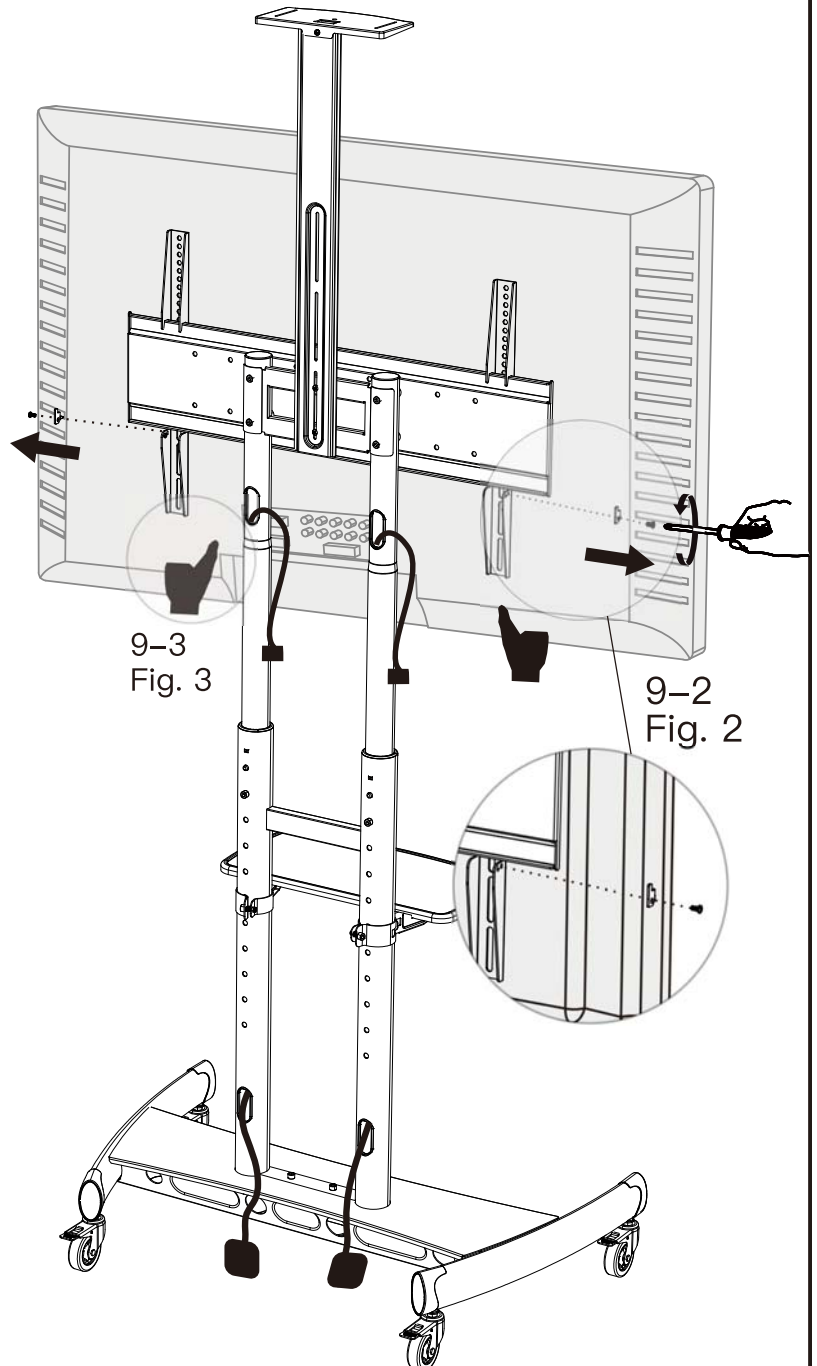
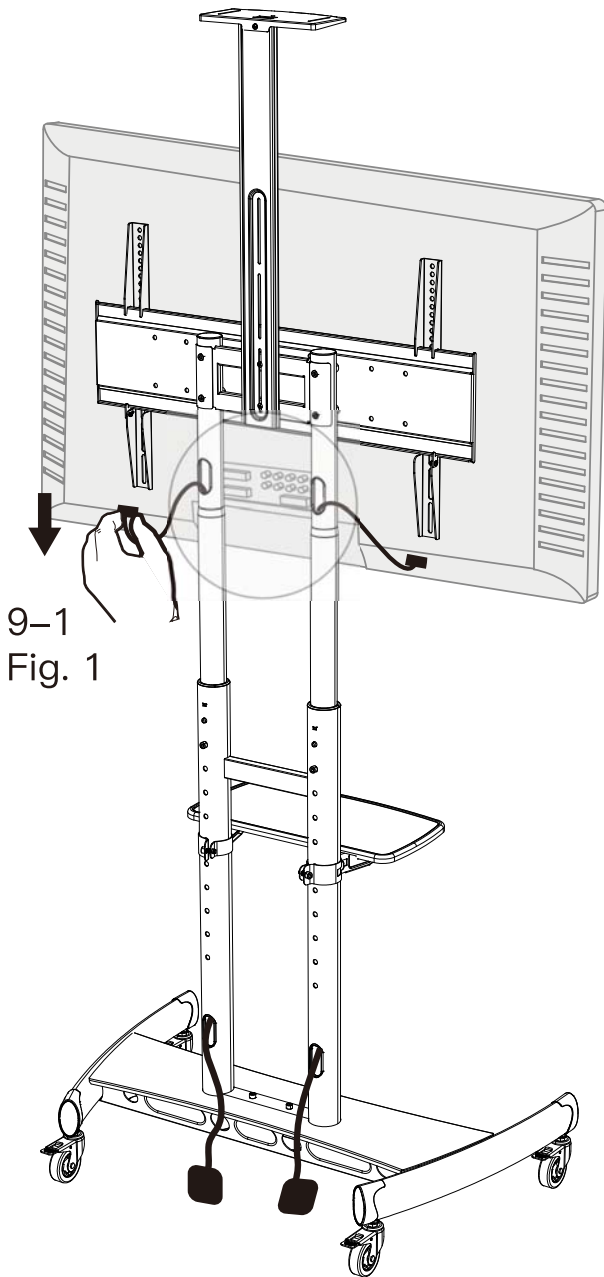
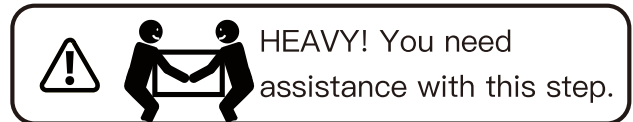

9-4 (Fig. 4) Remove Safety Bolts [S2] to Adjustment Pole. Using the spring balls on each Adjustment pole, reposition the TV Plate [05] to the desire height.

9-5 (Fig. 5) Ensure that the Spring Balls [S1] on both sides are fully engaged into a hole on the Adjustable Height Poles.

9-6 (Fig. 6) Carefully rehang TV with TV Brackets [07] on the TV Plate [05].

9-7 (Fig. 7) Re-install Safety Locks [F2] using Bolts [G2] on to the sides of the TV Brackets [07].

NOTE: Re-connect cables and TV's power cord.

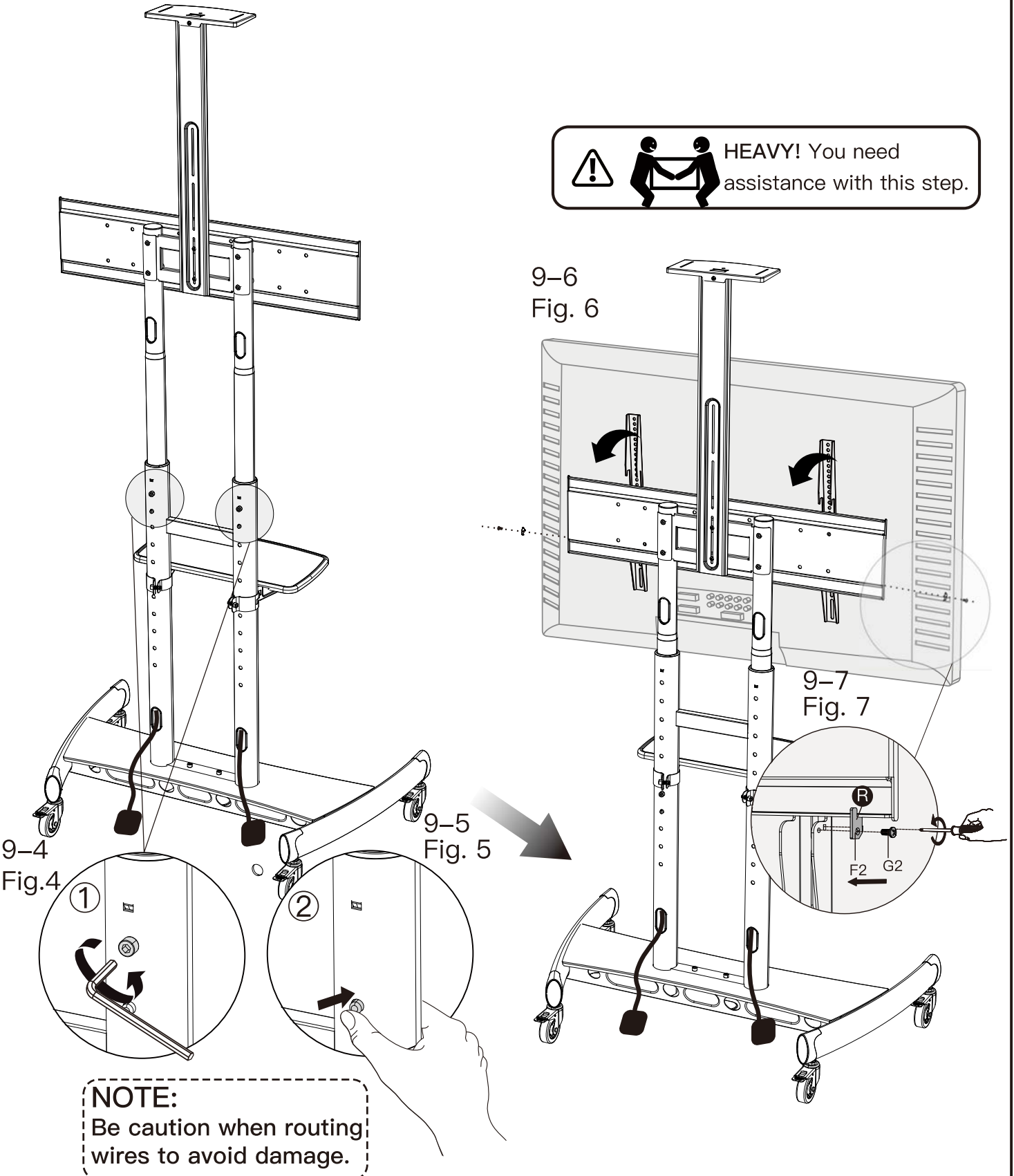



## Consignes de sécurité importantes

**⚠ DANGER !** Veuillez lire attentivement toutes les instructions avant de tenter l'installation. Si les instructions ne vous semblent pas claires ou si vous avez des questions, veuillez contacter notre service d'assistance technique au (877) 419-7832 ou notre service clientèle à l'adresse [support@ergoav.com](mailto:support@ergoav.com).

**⚠ ATTENTION :** L'utilisation avec des produits plus lourds que les poids max imums indiqués peut entraîner une instabilité et des blessures possibles.

- N'utilisez pas ce produit à des fins qui ne sont pas explicitement spécifiées dans ce manuel.
- Utilisez ce système de montage uniquement pour l'usage auquel il est destiné, tel que décrit dans ces instructions. N'utilisez pas d'accessoires supplémentaires non recommandés par le fabricant.
- Ne pas utiliser à l'extérieur. Ce produit est destiné à un usage intérieur uniquement.
- Ne dépassez pas la capacité de poids indiquée dans le manuel de ce produit. La surcharge des chariots audio et / ou vidéo avec des équipements supplémentaires ne se trouvant pas aux emplacements spécifiés peut entraîner la mort ou des blessures graves en raison de l'effondrement du chariot, de son instabilité pendant le déplacement ou de son basculement.
- Acheminez correctement les cordons et les câbles pour éviter tout dommage mécanique et tout risque de trébuchement.
- Des précautions supplémentaires doivent toujours être prises lors de l'utilisation de chariots à proximité d'enfants. Des objets intéressants, comme une télécommande, ou des jouets placés ou rangés sur le chariot pourraient inciter un enfant à grimper sur le chariot et le faire basculer. La mort ou des blessures graves peuvent survenir lorsque des enfants grimpent sur des chariots d'équipement audio et / ou vidéo.
- Nous ne sommes pas responsables des dommages ou blessures causés par un montage incorrect, un assemblage incorrect ou une utilisation inappropriée.
- SAUVEGARDER CES INSTRUCTIONS.

Avant de commencer l'assemblage, vérifiez que toutes les pièces sont incluses et en bon état. N'utilisez pas de pièces endommagées ou défectueuses. Si vous avez besoin de pièces de rechange, veuillez contacter notre support technique au (877) 419-7832 ou notre service clientèle à l'adresse [support@ergoav.com](mailto:support@ergoav.com).

## Vérifiez le modèle VESA du TV avant l'installation

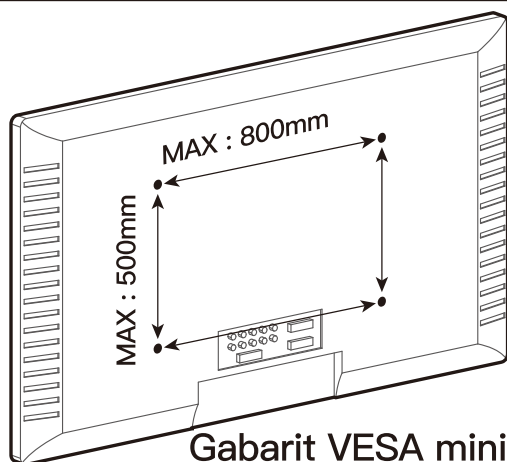

200mm	≈ 7 7/8 pouce
300mm	≈ 11 3/4 pouce
400mm	≈ 15 3/4 pouce
500mm	≈ 19 11/16 pouce
600mm	≈ 23 5/8 pouce
700mm	≈ 27 9/16 pouce
800mm	≈ 31 1/2 pouce

**Gabarit VESA minimal :** 200mm x 200mm / 7 7/8 po x 7 7/8 po (L x H)

**Max imum :** 800mm x 500mm / 31 1/2 po x 19 11/16 po (L x H)

Si le motif VESA de votre Téléviseur est inférieur à 200mm x 200mm ou supérieur à 800mm x 500mm, ce support n'est PAS COMPATIBLE avec votre Téléviseur.

Veuillez contacter notre support technique au (877) 419-7832 ou [support@ergoav.com](mailto:support@ergoav.com) pour trouver un support compatible.



## Restrictions de poids

**Maximum** Plateau supérieur Capacité de poids maximum : 10 lbs. (4,5 kg)

**Maximum** Capacité de poids maximum du Téléviseur : 200 lbs. (90 kg)

**Maximum** Capacité de poids MAX de l'étagère : 10 lbs. (4,5 kg)

**Maximum** Support de Télévision  
200 lbs. / 90 kg

**Maximum** Étagère pour  
10 lbs. / 4,5 kg

**Maximum** Plateau supérieur  
10lbs / 4,5kg

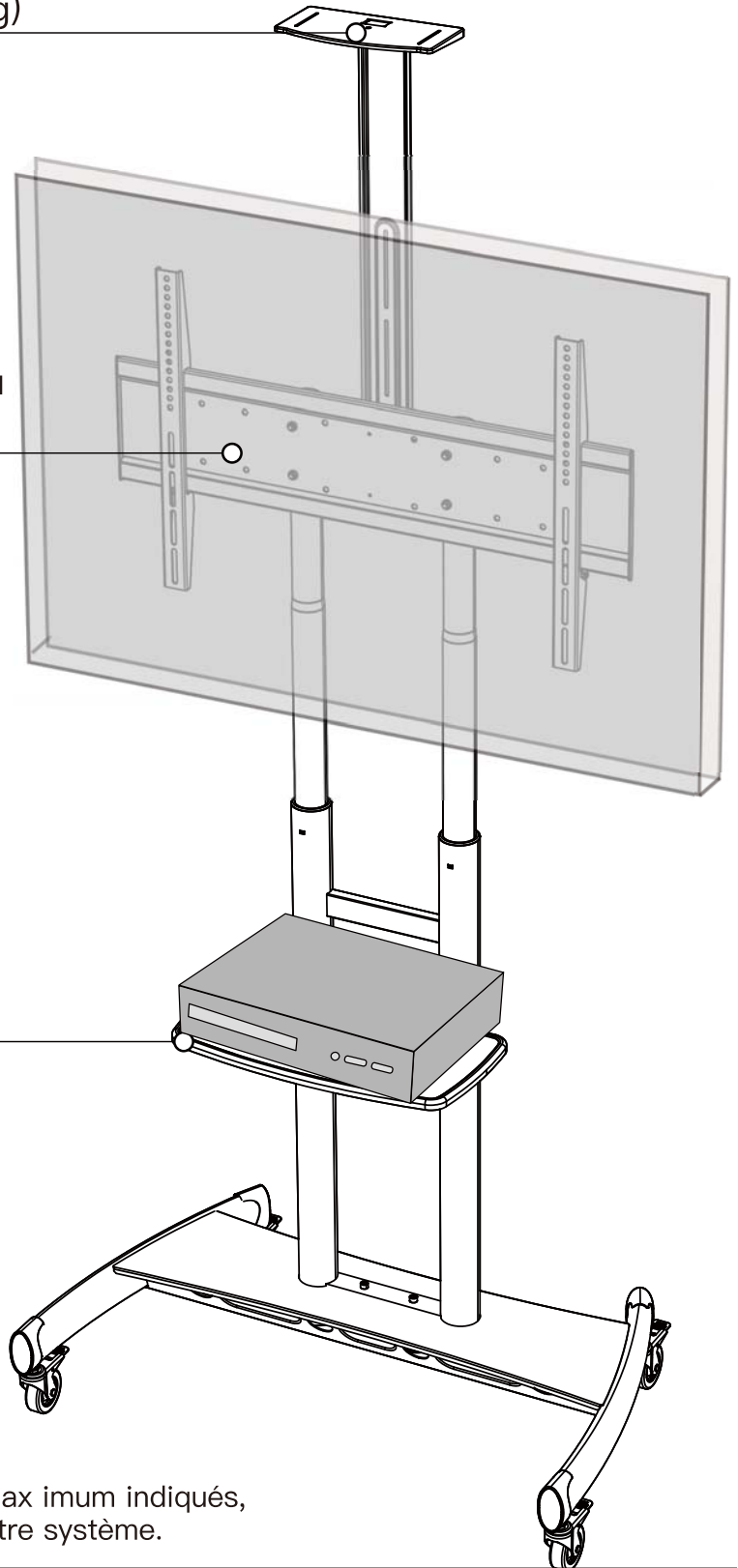

**!** Si vos produits pèsent plus que les poids maximum indiqués, ce chariot TV n'est pas compatible avec votre système.

### **!** AVERTISSEMENT

NE PAS dépasser le poids maximum indiqué. Ce système de montage est destiné à être utilisé uniquement dans la plage de poids indiquée. L'utilisation de produits plus lourds que la limite de poids maximale peut entraîner une défaillance du support et causer des dommages potentiels ou des blessures.

## Outils nécessaires (non inclus)



Phillips Screwdriver



Clé  
3/4 po (19mm)

## Pièces et matériel fournis pour l'étape 1

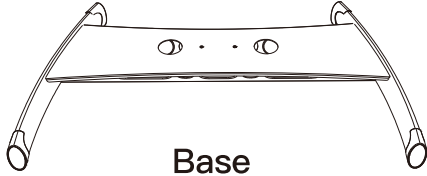

Base

**01** x 1



Roue

**02** x 4

## Étape 1 Fix ation des roulettes à la base

1-1 Retournez la base [01] de sorte que le bas de la base [01] soit en position haute.

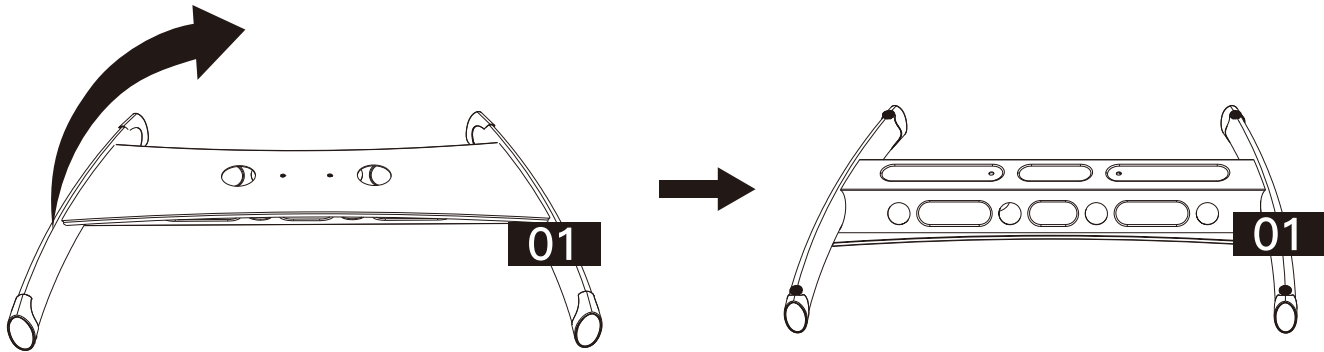

1-2 Positionnez la languette de verrouillage vers le bas pour verrouiller la roulette [02]. Vissez les roulettes [02] dans la Base [01] et serrez avec la clé fournie.

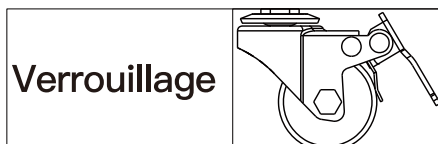
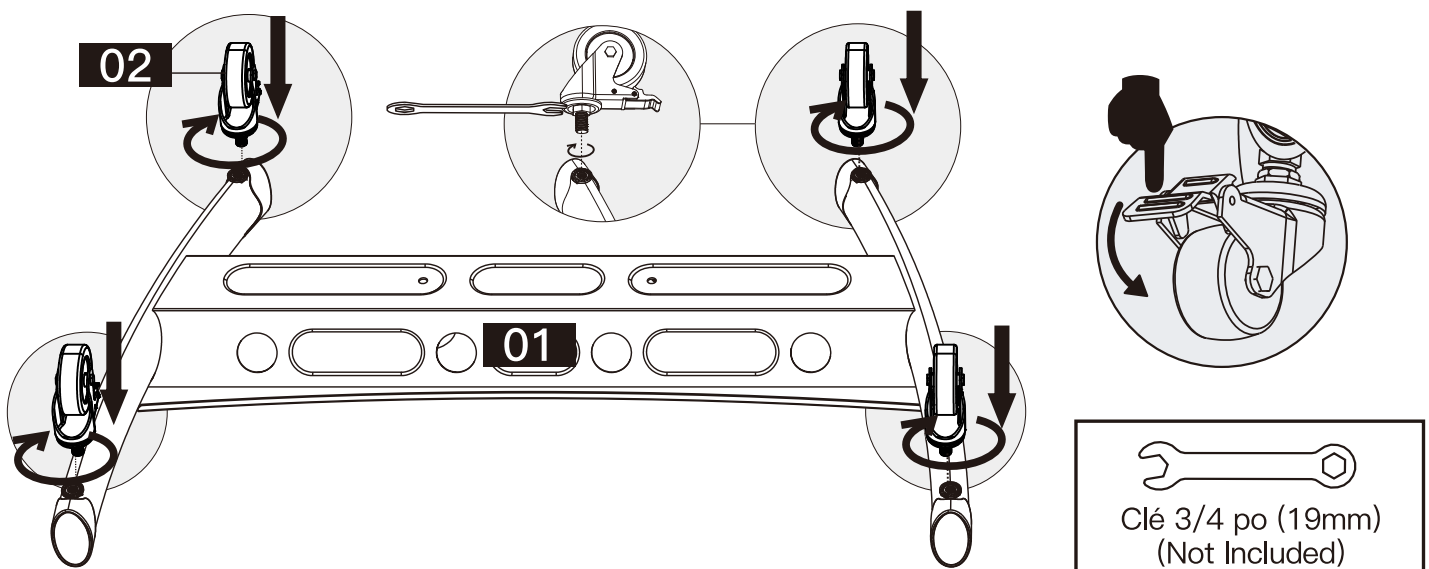

Remarque : Veuillez verrouiller les roulettes [02] pour éviter qu'elles ne bougent pendant le montage.

## Pièces et matériel fournis pour l'étape 2

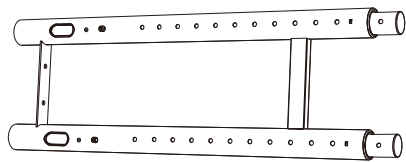

Poteau réglable en hauteur

**03** x 1



Boulon  
M8 X 20mm  
A2 x 4



Clé Allen  
M6  
E2 x 1

## Étape 2 Connecter l'ensemble du poteau à la base

2-1 Insérez le poteau réglable en hauteur [03] dans la base [01] comme indiqué ci-dessous. Insérez deux boulons [A2] à travers le poteau réglable en hauteur dans la base [01].

2-2 Insérez les deux autres boulons [A2] à travers la base [01] et dans les inserts filetés au bas du poteau réglable en hauteur [03]. Serrez les quatre boulons [A2] avec la clé Allen [E2] jusqu'à ce qu'ils soient bien serrés.

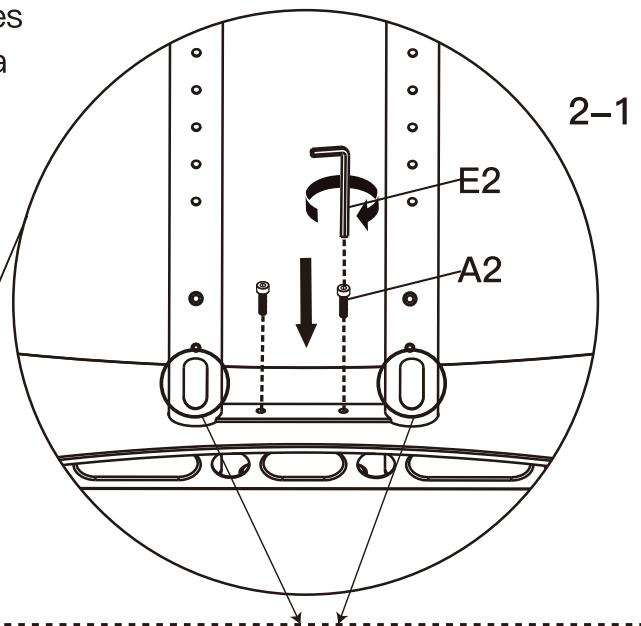
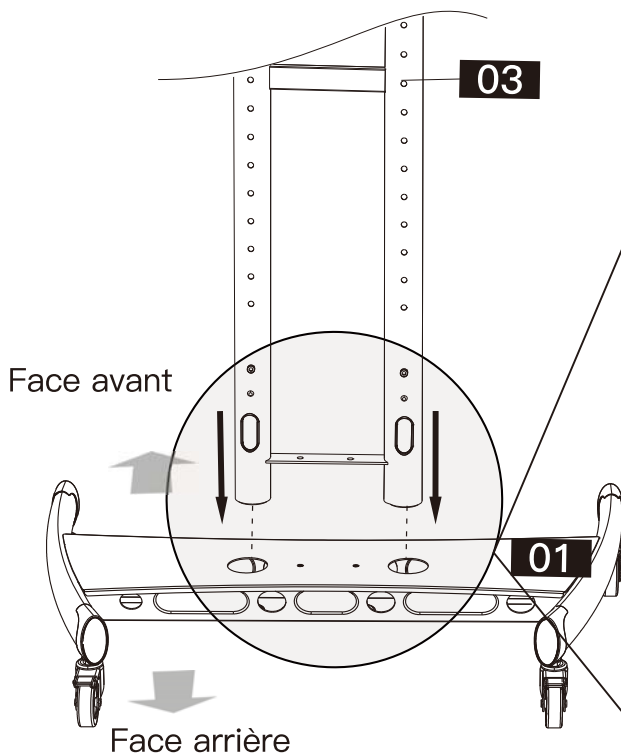

**Remarque :** Assurez-vous que les fenêtres de gestion des câbles sont orientées vers l'arrière de la base.

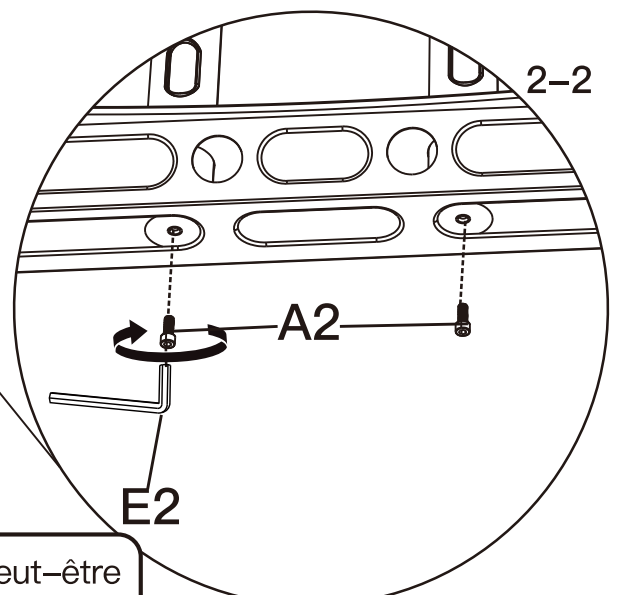

Côté inférieur



**LOURD !** vous aurez peut-être besoin d'aide pour cette étape.

## Étape 3 Ajuster la hauteur du poteau

3-1. (Fig. 1) Dévissez le boulon de sécurité préassemblé [S2] sur l'ensemble des pôles inférieurs droits à l'aide de [E2] (clé Allen de 6mm) et conservez-le pour l'utilisation de l'étape 3-4.

3-2. (Fig. 2) Utilisez le pouce ou l'index de la main gauche pour enfoncer la billes de ressort [S1] située sur le montant inférieur droit (près de la fenêtre du câble), en même temps utilisez la main droite pour tourner et tirer le montant supérieur droit (dans le sens des aiguilles d'une montre ou dans le sens inverse) vers le haut à la hauteur souhaitée.

3-3. (Fig. 3) Utilisez l'indicateur de l'étiquette de hauteur sur le poteau comme guide. Ensuite, tournez la tige supérieure de dans le sens des trous du plongeur et engagez la bille du ressort [S1] dans le trou du plongeur de .

3-4. (Fig. 4) Fixez fermement le boulon de sécurité [S2] à l'aide de [E2] (clé Allen de 6 mm).

**REMARQUE :** Veuillez suivre les procédures des étapes 3-1 à 3-4 pour retirer le montant supérieur gauche.

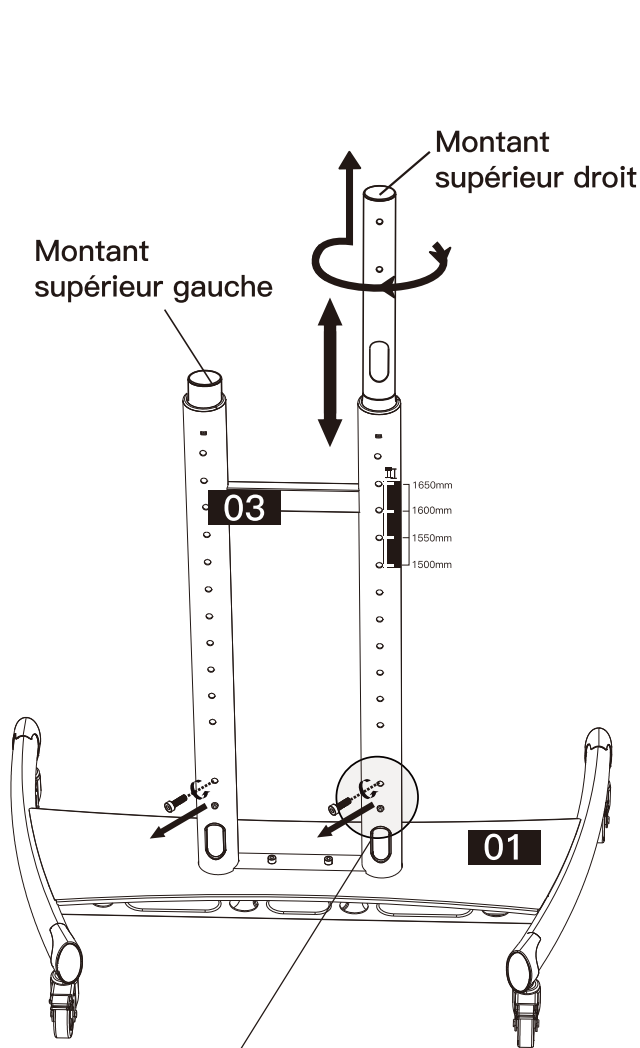

Fig. 1

Fig. 2

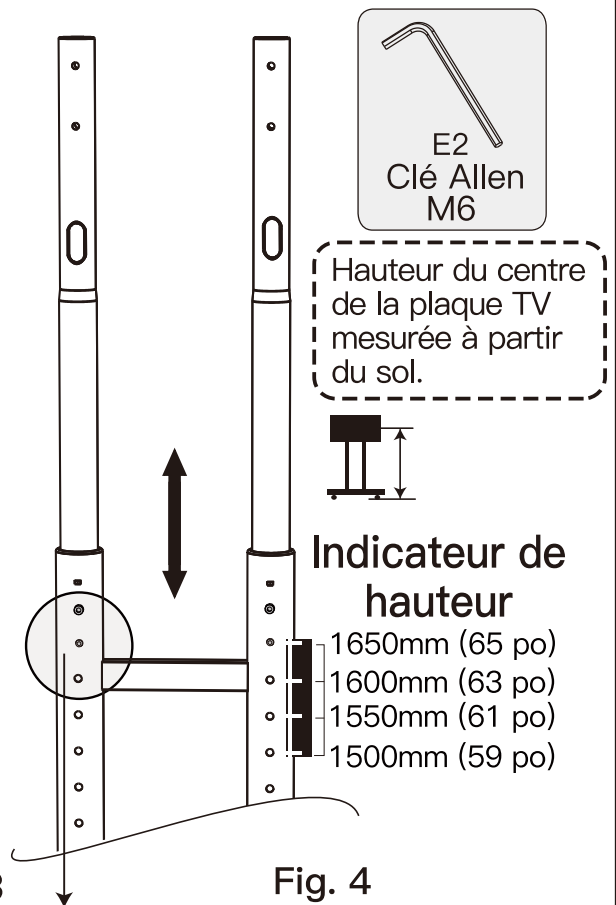
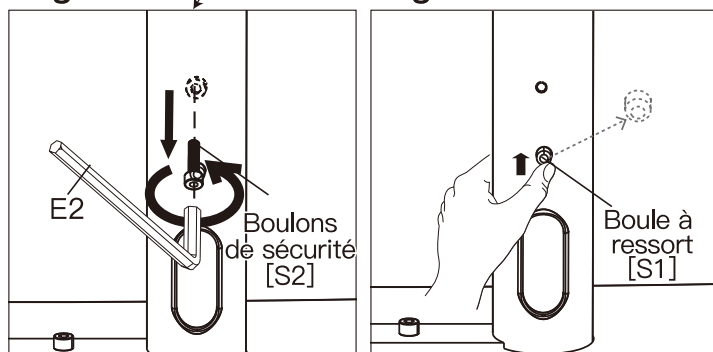
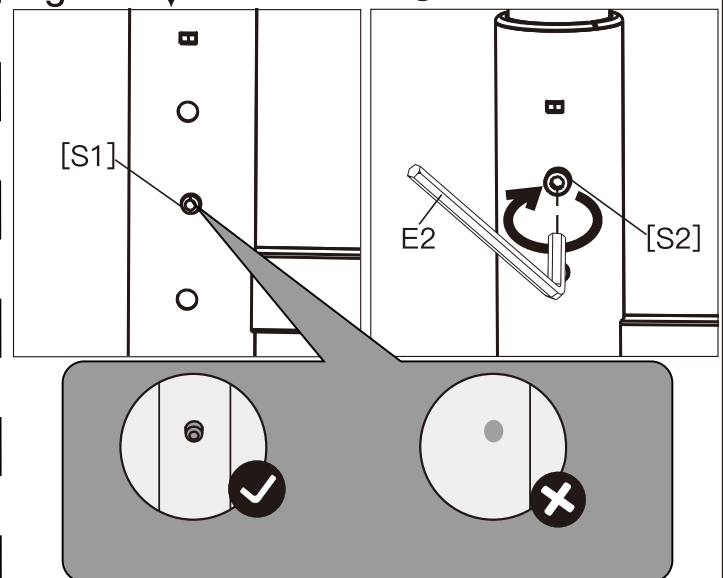

Fig. 3

Fig. 4



## Pièces et matériel fournis pour l'étape 4



Couvercle du  
câble

**04** x 2

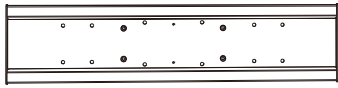

Plaque TV

**05** x 1

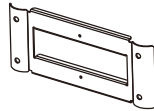

Plaque de  
connexion

**06** x 1



Boulon  
M8 X 72mm  
B2 x 4



Entretoises  
L13mm  
D2 x 4



Clé Allen  
M6  
E2 x 1

## Étape 4 Fixer la Plaque de connexion et la plaque TV sur le poteau réglable en hauteur



E2  
Clé Allen  
M6

Fixez les couvercles de câble [04]. Insérez les boulons [B2] dans la Plaque de connexion [06], les pôles supérieurs de , les entretoises [D2] et la plaque TV [05]. Serrez avec la clé Allen [E2] jusqu'à ce qu'elle soit bien fixée.



4-2

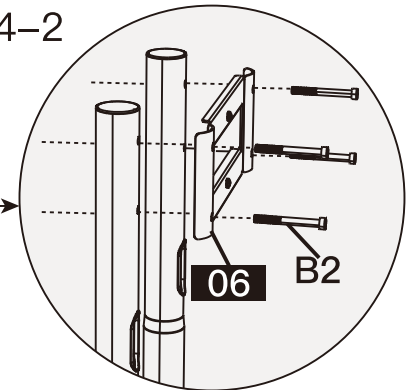

4-3

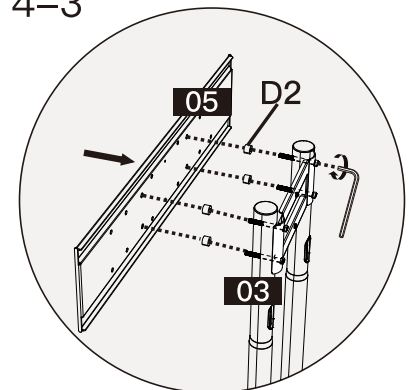

4-4

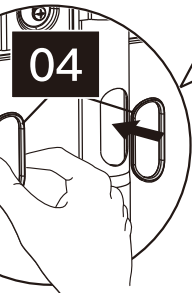
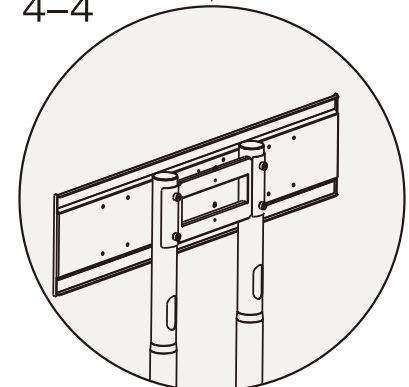

**04**

 vous aurez peut-être besoin d'aide pour cette étape.

 **Attention :**  
Assurez-vous que les boulons sont fixés fermement.

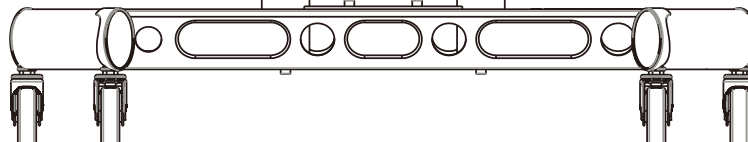

# Pièces et matériel fournis pour l'étape 5

Remarque : Les rondelles et les entretoises sont représentés en taille réelle.

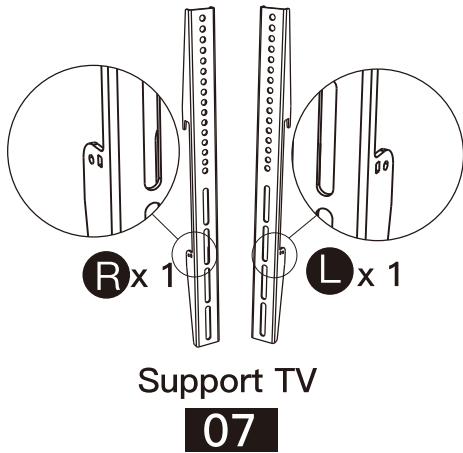

## Rondelle



M4 / M6  
H1 x 4



M8  
H2 x 4

## Entretoises [Au besoin]

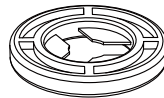

L2.5mm  
I x 8

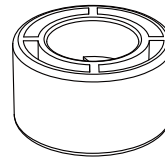

L10mm  
J x 4

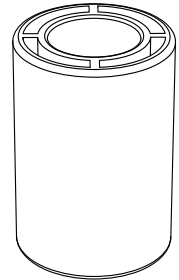

L23mm  
K x 4

## Boulon TV

[Une seule taille de boulon fits votre Téléviseur]

Remarque : Les boulons sont représentés en taille réelle.

M4



M4 x 30mm  
[A] x 4

M6

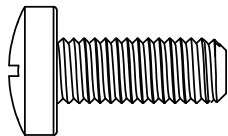

M6 x 16mm  
[B] x 4

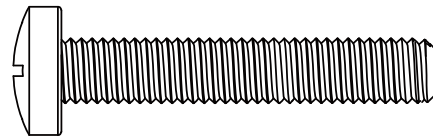

M6 x 35mm  
[C] x 4

M8

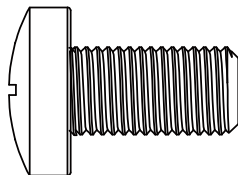

M8 x 15mm  
[D] x 4

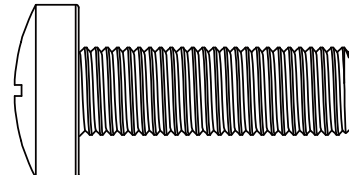

M8 x 25mm  
[E] x 4

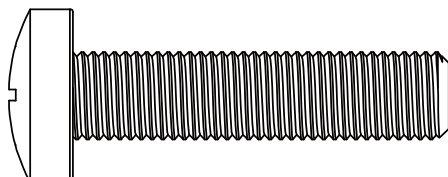

M8 x 35mm  
[F] x 4

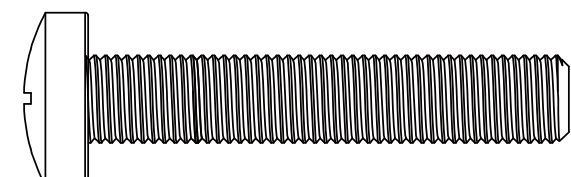

M8 x 50mm  
[G] x 4



# Étape 5 Fix ation des supports TV au Téléviseur

## Sélectionnez les boulons TV

Une seule taille de boulon convient à votre téléviseur.

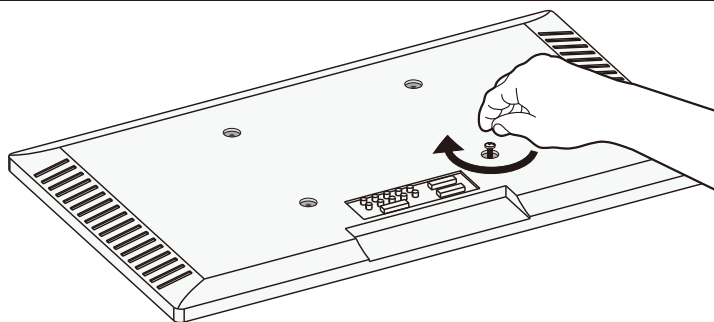
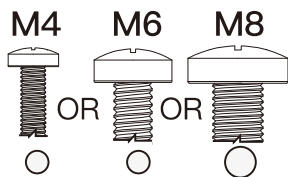

Longueur de la boulon : Vérifiez que le filetage est correctement engagé avec les boulons ou la combinaison boulons / entretoises. Nous recommandons un engagement du filetage sur au moins 5 tours.

- Trop court, le téléviseur ne sera pas maintenu.
- Trop long, le téléviseur sera endommagé.

**REMARQUE :** Ne serrez pas trop les boulons de téléviseur pour ne pas l'endommager.

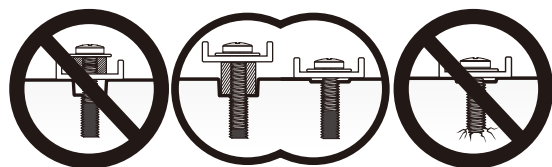

Trop court      Correct      Trop long

**Veillez noter :** Lors de l'utilisation des entretoises, il est important de noter qu'elles peuvent être utilisées sur plusieurs couches (c'est-à-dire empilées).

Si vous rencontrez des difficultés pour comprendre comment installer les boulons ou les entretoises du téléviseur, veuillez contacter notre service d'assistance technique au (877) 419-7832 ou notre service clientèle à l'adresse [support@ergoav.com](mailto:support@ergoav.com).

## Les pièces nécessaires si vous avez un téléviseur tel qu'indiqué ci-après

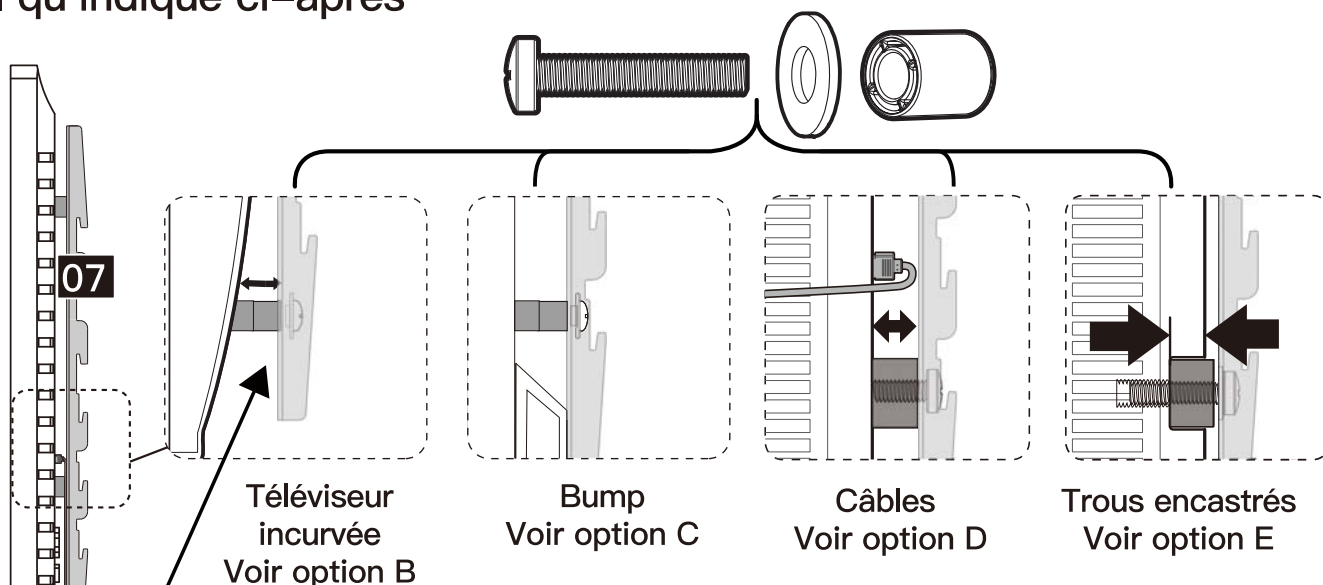

### Entretoises

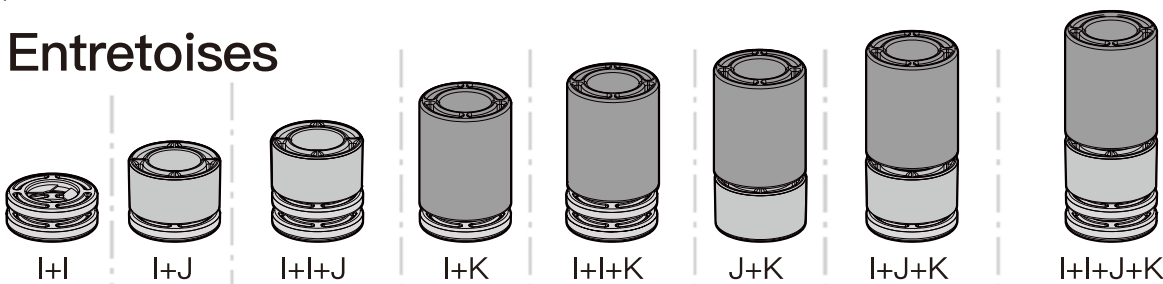



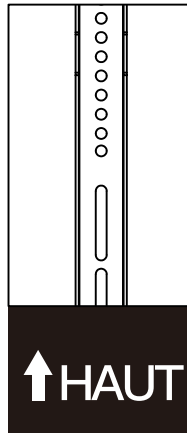
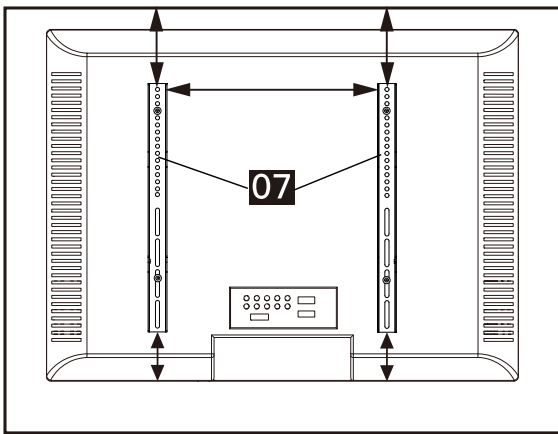

**⚠ ATTENTION :** Lorsque vous fixez les supports TV [07] sur à l'arrière du Téléviseur, assurez-vous que les extrémités avec les trous arrondis sont orientées vers le haut du Téléviseur et également centrées à l'arrière du Téléviseur.

**⚠ EUILLEZ NOTER :** Les emplacements des trous de boulon sur votre téléviseur peuvent varier en fonction du design du fabricant du téléviseur. Nous représentons seulement les emplacements possibles des trous des boulon.

### Option A (Pour un téléviseur à dos plat)

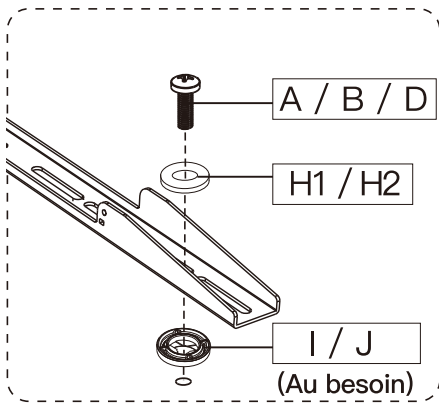

Reportez-vous aux instructions d'entretoise de la page 25, si nécessaire.

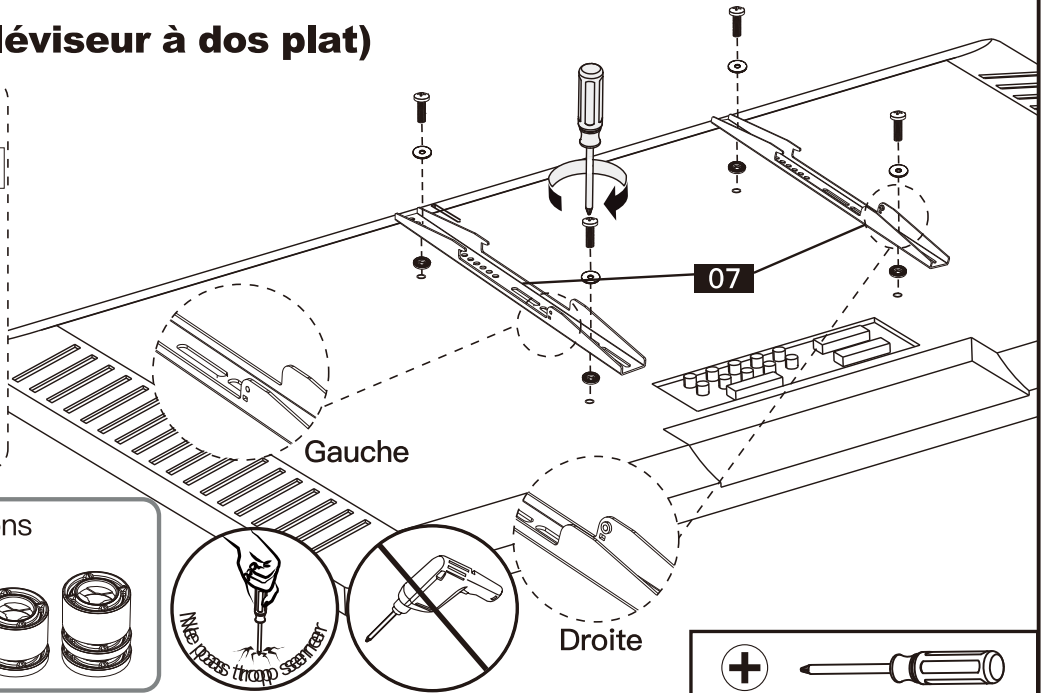

**+**   
Tournevis Phillips  
(Non inclus)

### Option B (Pour un téléviseur à dos arrondi)

La hauteur des entretoises doit être suffisante pour éviter que la courbe à l'arrière du téléviseur n'interfère avec la plaque de montage.

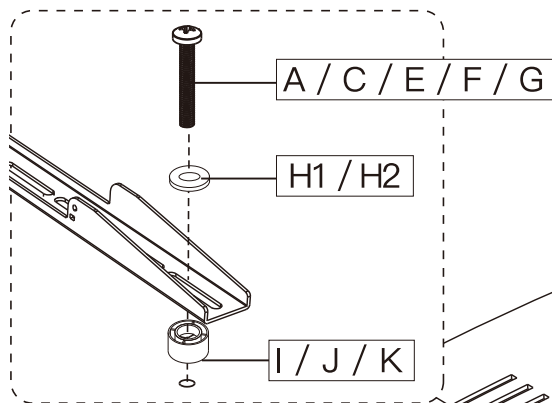

Reportez-vous aux instructions d'entretoise de la page 25, si nécessaire.

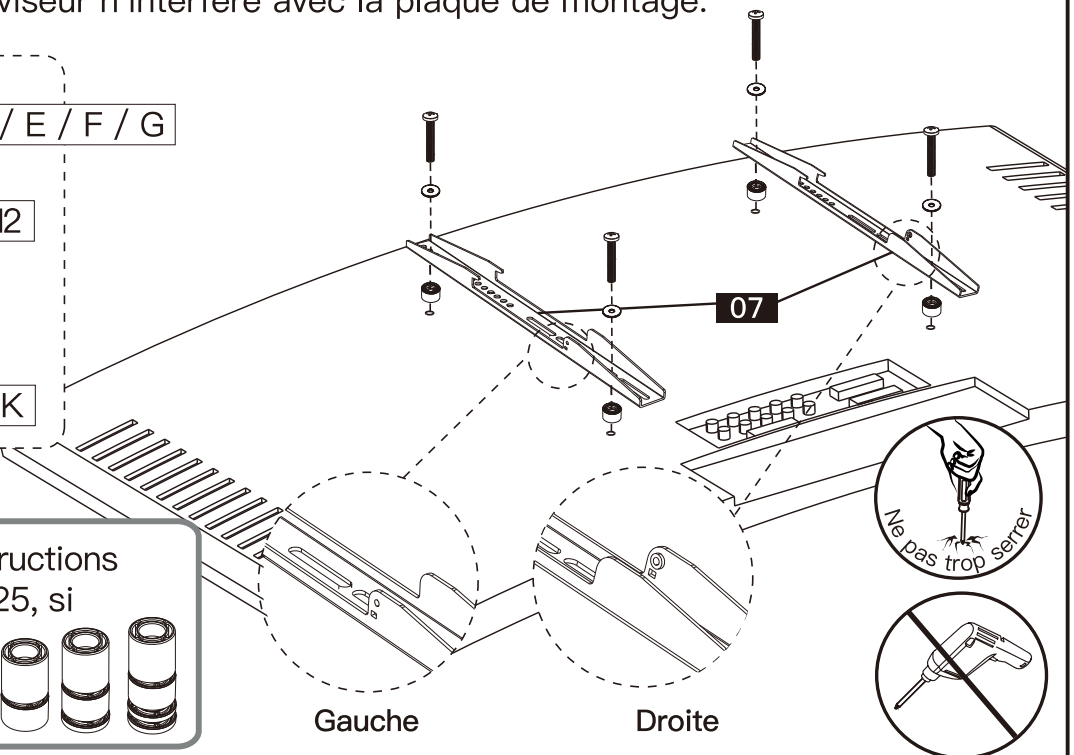

### Option C (Pour un téléviseur avec une surépaisseur)

Les entretoises doivent être suffisamment hautes pour qu'il n'y ait pas d'espace entre le support TV et la bosse à l'arrière du Téléviseur.



Tournevis Phillips  
(Non inclus)

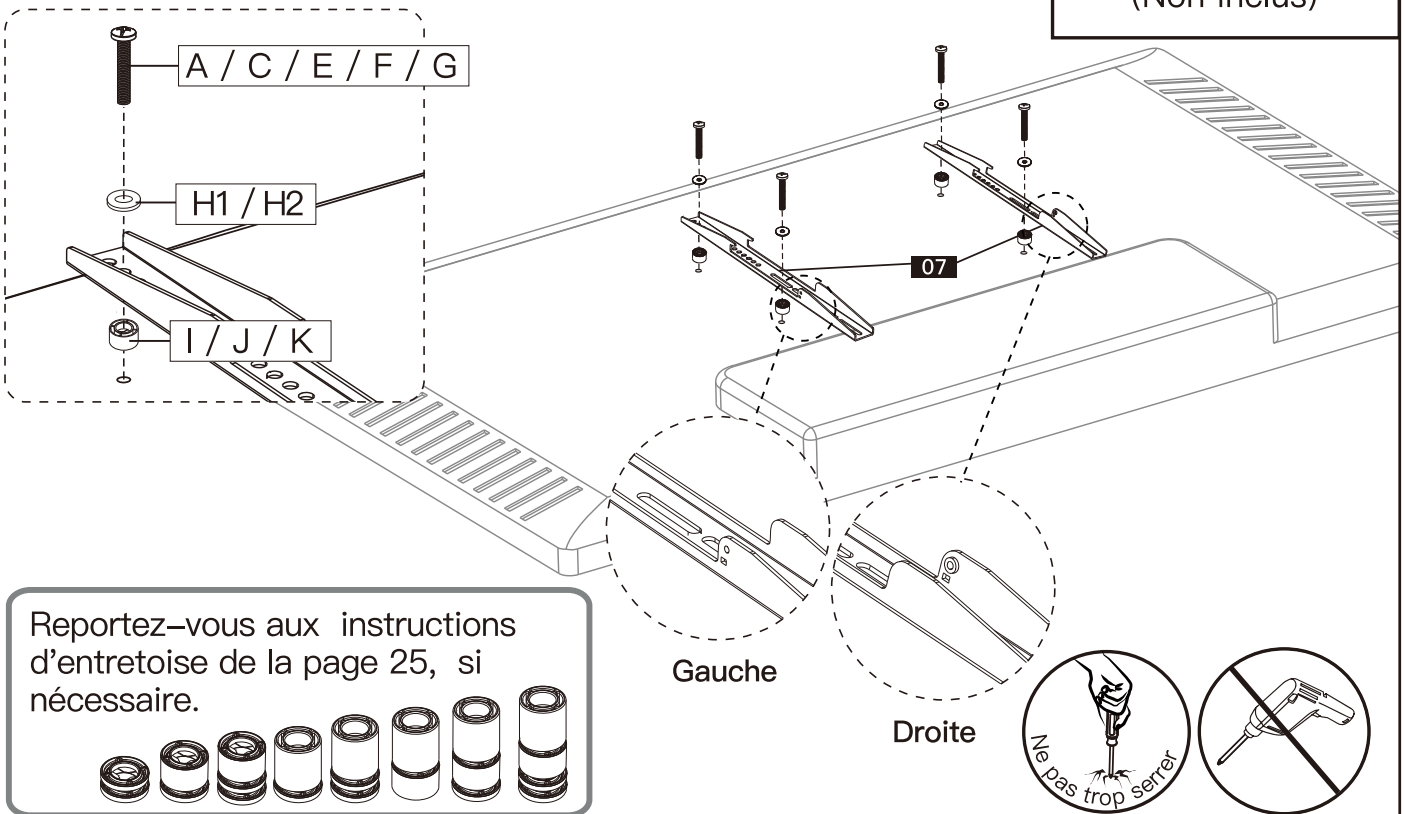

Reportez-vous aux instructions d'entretoise de la page 25, si nécessaire.

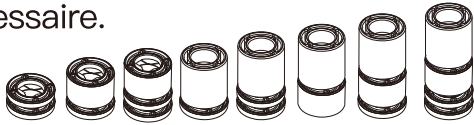

### Option D (Pour téléviseur avec interférence du câble)

Pour éviter les interférences entre les câbles, utilisez les entretoises [I], [J] and [K] pour créer un espace supplémentaire entre le téléviseur et les supports TV.



Tournevis Phillips  
(Non inclus)

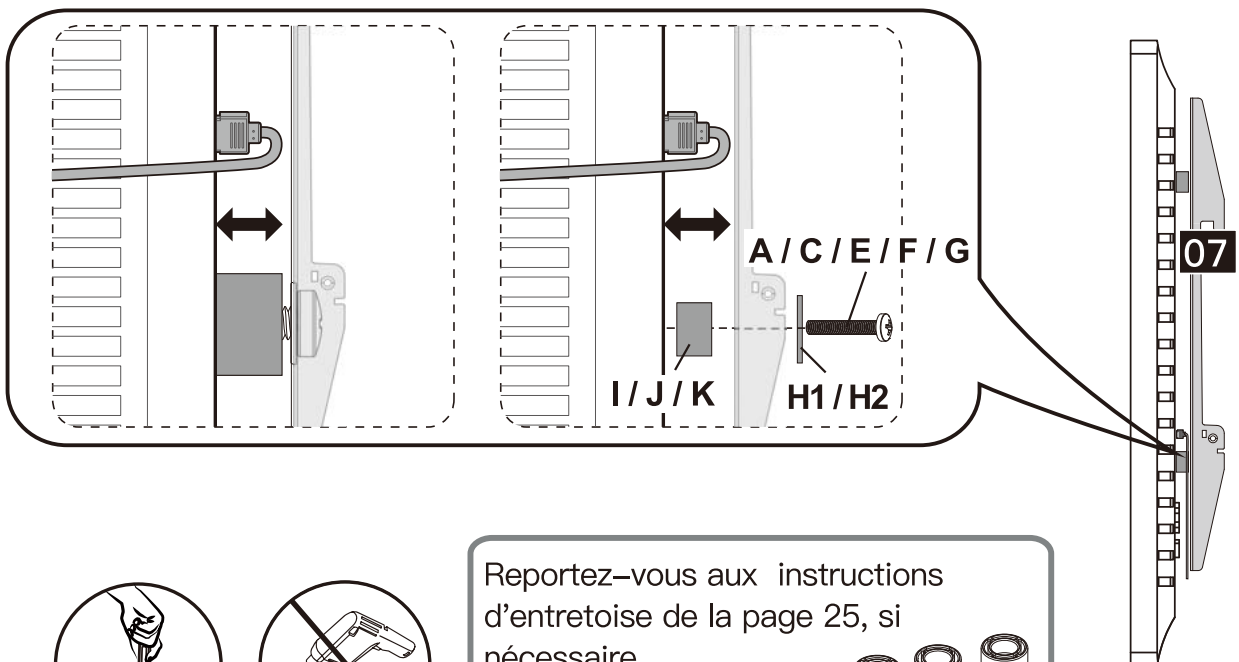

Reportez-vous aux instructions d'entretoise de la page 25, si nécessaire.



### Option E (Pour un téléviseur avec une surépaisseur)

Les entretoises [I, J et K] doivent remplir les trous en retrait sur la base du Téléviseur afin que les supports TV soient aussi proches que possible du Téléviseur.



Tournevis Phillips  
(Non inclus)

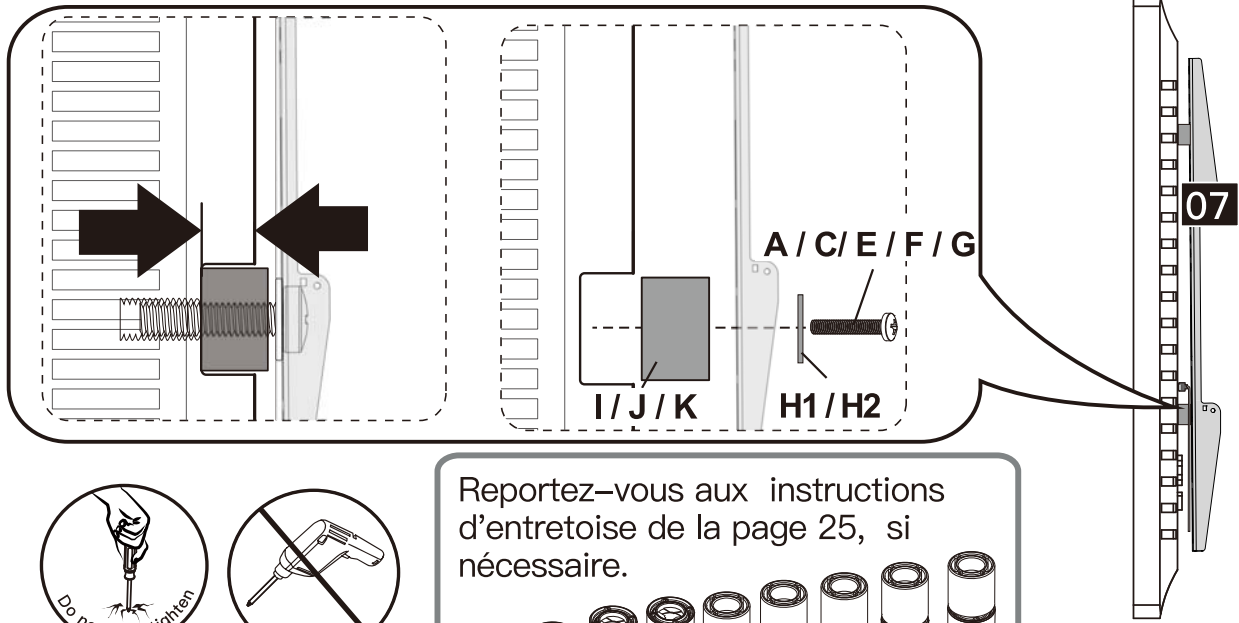

Reportez-vous aux instructions d'entretoise de la page 25, si nécessaire.

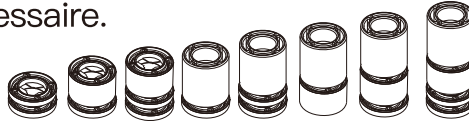

### Pièces et matériel fournis pour l'étape 6

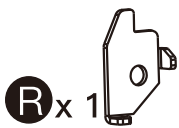

L x 1

Verrou de sécurité  
F2



Boulon  
M5 x 12mm  
G2 x 2

### Étape 6 Accrocher le Téléviseur à la plaque TV

6-1. Suspendez le Téléviseur à l'aide des supports TV [07] sur la plaque TV [05].

Remarque : Le Téléviseur doit être accroché au centre de la plaque TV pour garder l'équilibre.

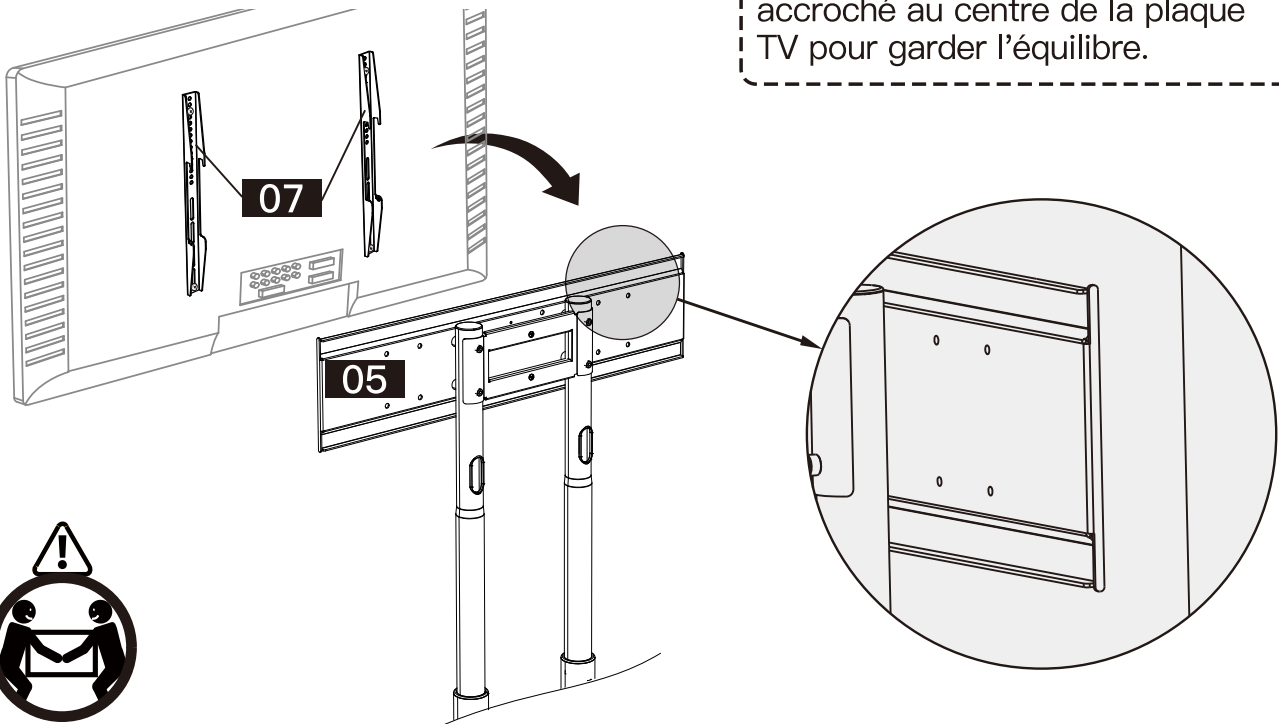

6-2. Insérer les boulons [G2] dans les verrous de sécurité [F2] et visser dans le support TV [07]. Serrez avec un tournevis Phillips.

**Remarque :** Déplacez le Téléviseur au centre.

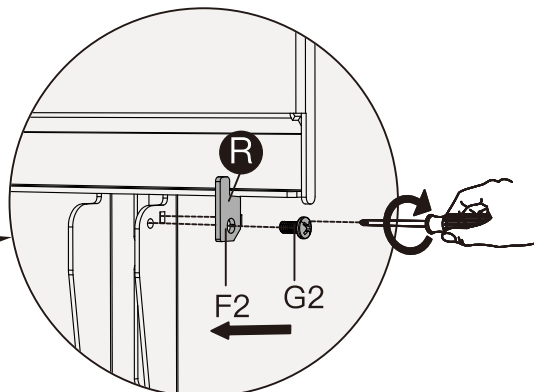
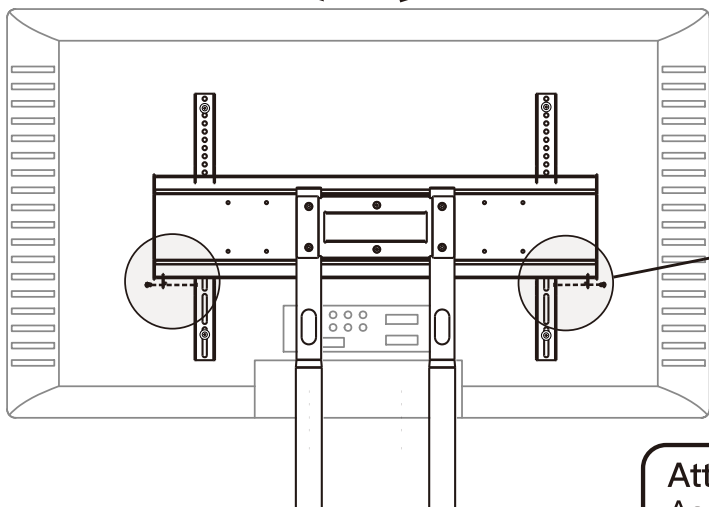

**Attention :** Assurez-vous que les boulons sont fixés fermement.

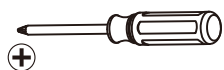

Tournevis Phillips (Non inclus)

## Pièces et matériel fournis pour l'étape 7

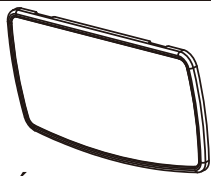

Étagère AV  
**08** x 1

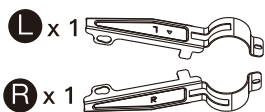

Support d'étagère AV  
**09**



Anneau  
**10** x 2



Boulon M8 X 20mm  
A2 x 2



Clé Allen M6  
E2 x 1

## Étape 7 Fixer le plateau AV au poteau réglable en hauteur

**7-1-1**

Alignez les trous des supports d'étagère [09] avec les bosses situées au bas de l'étagère AV [08].

**7-1-2**

Tirez le support d'étagère [09] vers l'arrière de l'étagère AV [08] jusqu'à ce que le support d'étagère [09] soit verrouillé sur la bosse de l'étagère AV [08]. Déplacez les extrémités de chaque support d'étagère [09] vers le centre jusqu'à ce que les languettes du support d'étagère AV [09] soient complètement insérées dans les fentes de l'étagère AV [08].

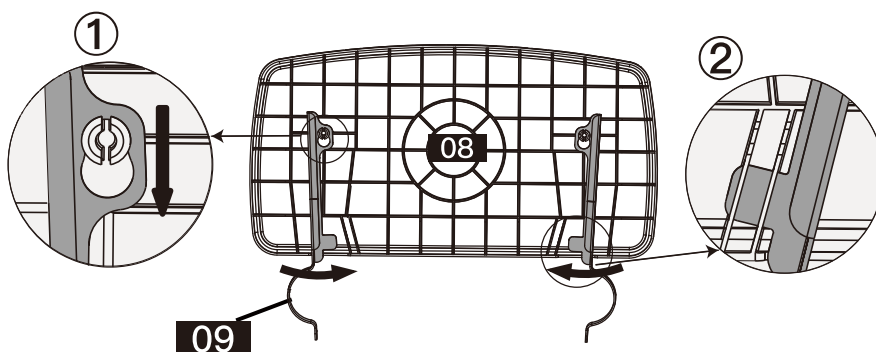
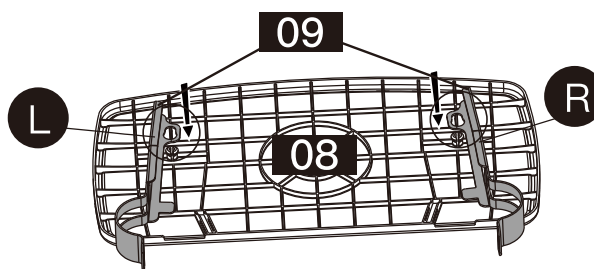

**7-1-3** Fixez un anneau [10] à chacun des supports d'étagère AV [09].

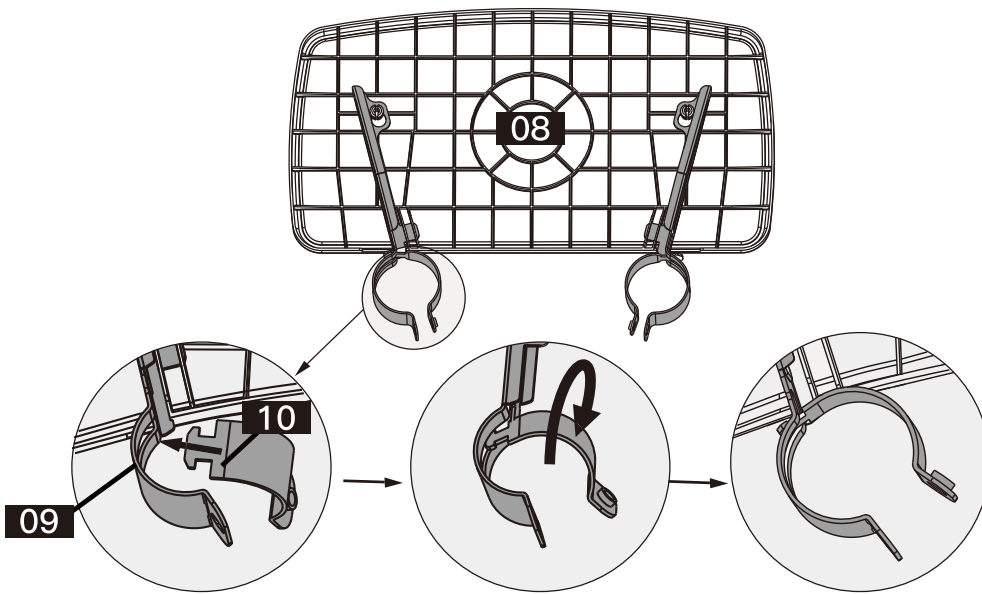

**7-2-1** Fixez l'ensemble de l'étagère AV au montant réglable en hauteur [03].

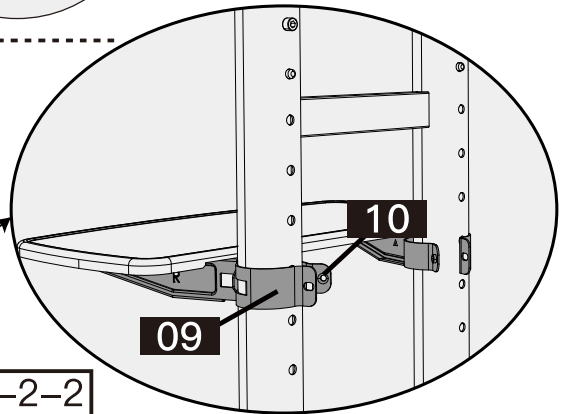
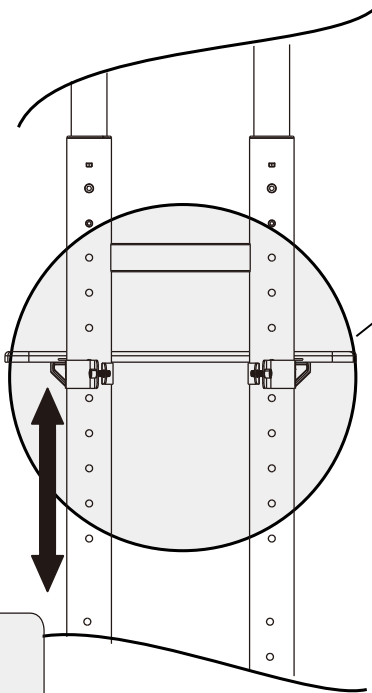

**7-2-2**

Fixez l'ensemble de l'étagère AV au poteau réglable en hauteur [03] en fixant les boulons [A2] à l'aide de la clé Allen [E2].

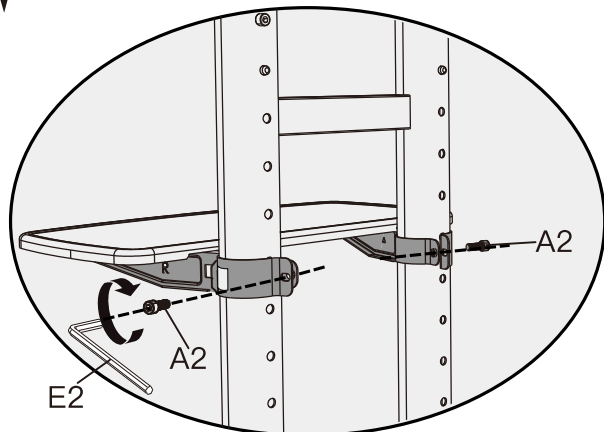

## Pièces et matériel fournis pour les étapes 8-9



Support de plateau vidéo  
**11** x 1



Plateau vidéo  
**12** x 1



Boulon  
M5 x 10mm  
C2 x 1



## Étape 8 Installer le support de plateau vidéo sur la Plaque de connection

8-1 Fixez le plateau vidéo [12] sur le haut du support de plateau vidéo [11] à l'aide du boulon [C2].

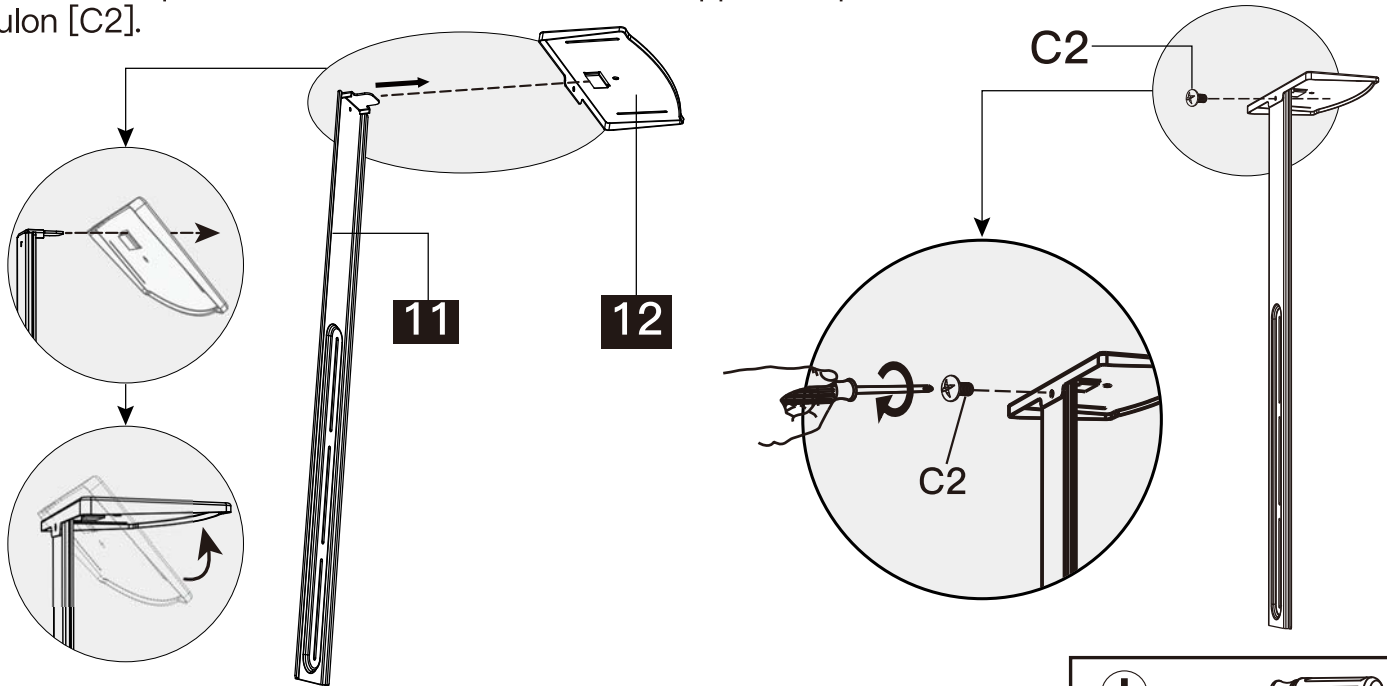

8-2. Retirez les boulons préassemblés [S3] de la Plaque de connection [06] et conservez-les pour l'étape 8-3.

8-3. Fixez le support de plateau vidéo [11] sur la Plaque de connection [06] et serrez-le avec les boulons préassemblés [S3].

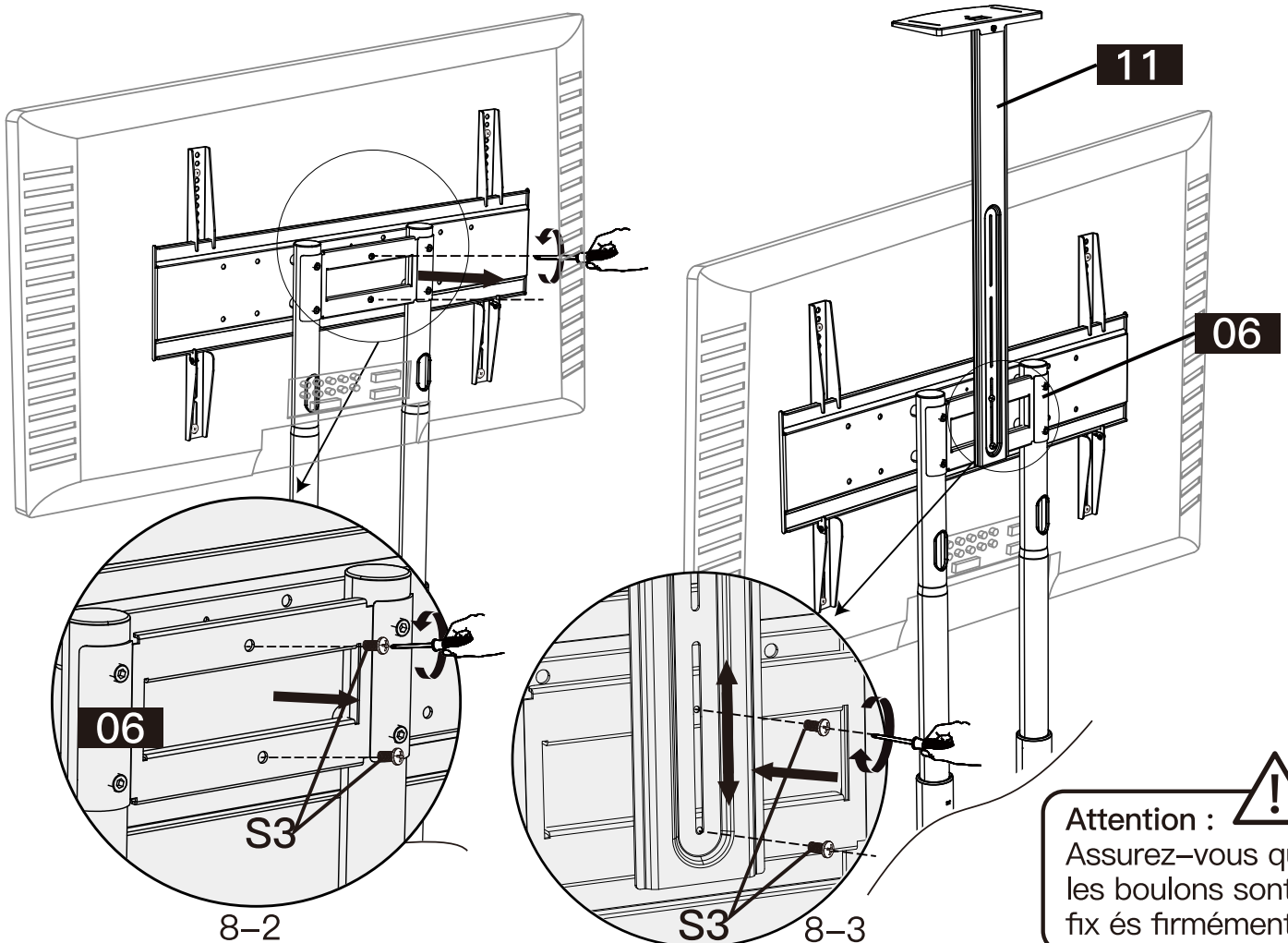

**Attention :**  Assurez-vous que les boulons sont fixés fermement.

## Étape 9 Réglage de la hauteur du Téléviseur et gestion des câbles (en option)

**▲ AVERTISSEMENT :** Le fait de régler la position en hauteur du Téléviseur alors que celui-ci est connecté au chariot du Téléviseur peut entraîner des blessures corporelles et / ou des dommages matériels.  
Même avec plus d'une personne, n'essayez jamais de régler la hauteur du Téléviseur lorsque le Téléviseur est connecté au chariot du Téléviseur.

S'il est déterminé que la hauteur du téléviseur doit être ajustée, elle peut être ajustée en suivant les étapes indiquées ci-dessous.

9-1 (Fig. 1) Remove all cables from the TV and disconnect the TV's power cord.

9-2 (Fig. 2) Remove Bolt [G2] and Safety Locks [F2] from the side of the TV Brackets [07].

9-3 (Fig. 3) Carefully remove the TV with TV Brackets from the TV Plate [05]. Place the TV in a safe area that is out of the way.

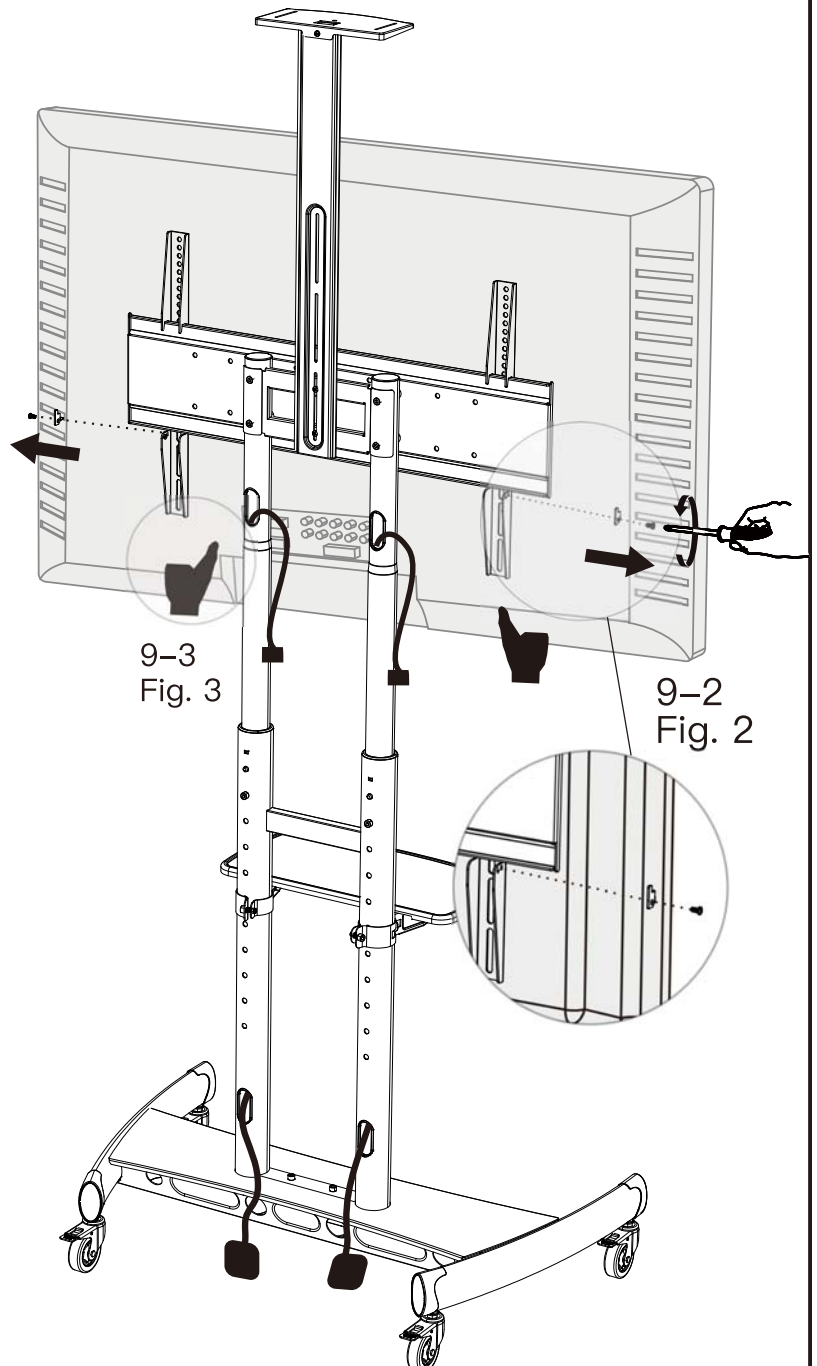
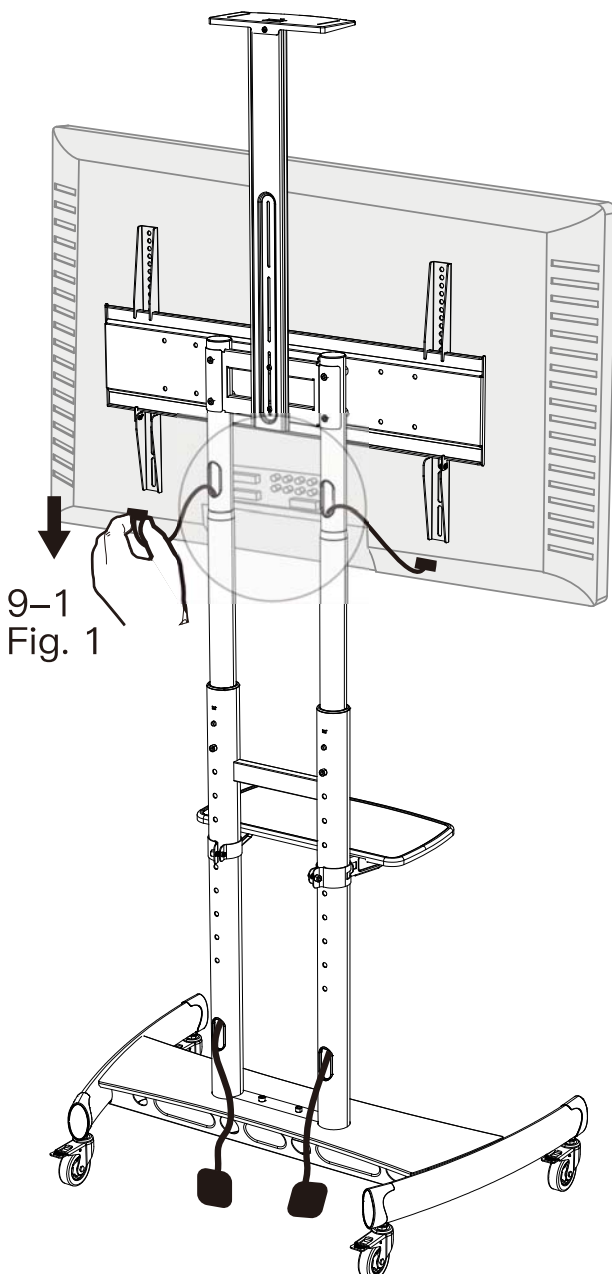

9-3  
Fig. 3

9-2  
Fig. 2



9-4 (Fig. 4) Retirez les boulons de sécurité [S2] de la perche de réglage. A l'aide des billes à ressort [S1] de chaque pôle de réglage, repositionnez la plaque TV [05] à la hauteur souhaitée.

9-5 (Fig. 5) Assurez-vous que les billes de ressort [S1] des deux côtés de sont complètement engagées dans un trou sur les poteaux à hauteur réglable.

9-6 (Fig. 6) Replacer avec précaution le Téléviseur avec les supports TV [07] sur la plaque TV [05].

9-7 (Fig. 7) Réinstallez les verrous de sécurité [F2] à l'aide des boulons [G2] sur les côtés du support TV [07].

**REMARQUE :** Rebranchez les câbles et le cordon d'alimentation du Téléviseur.

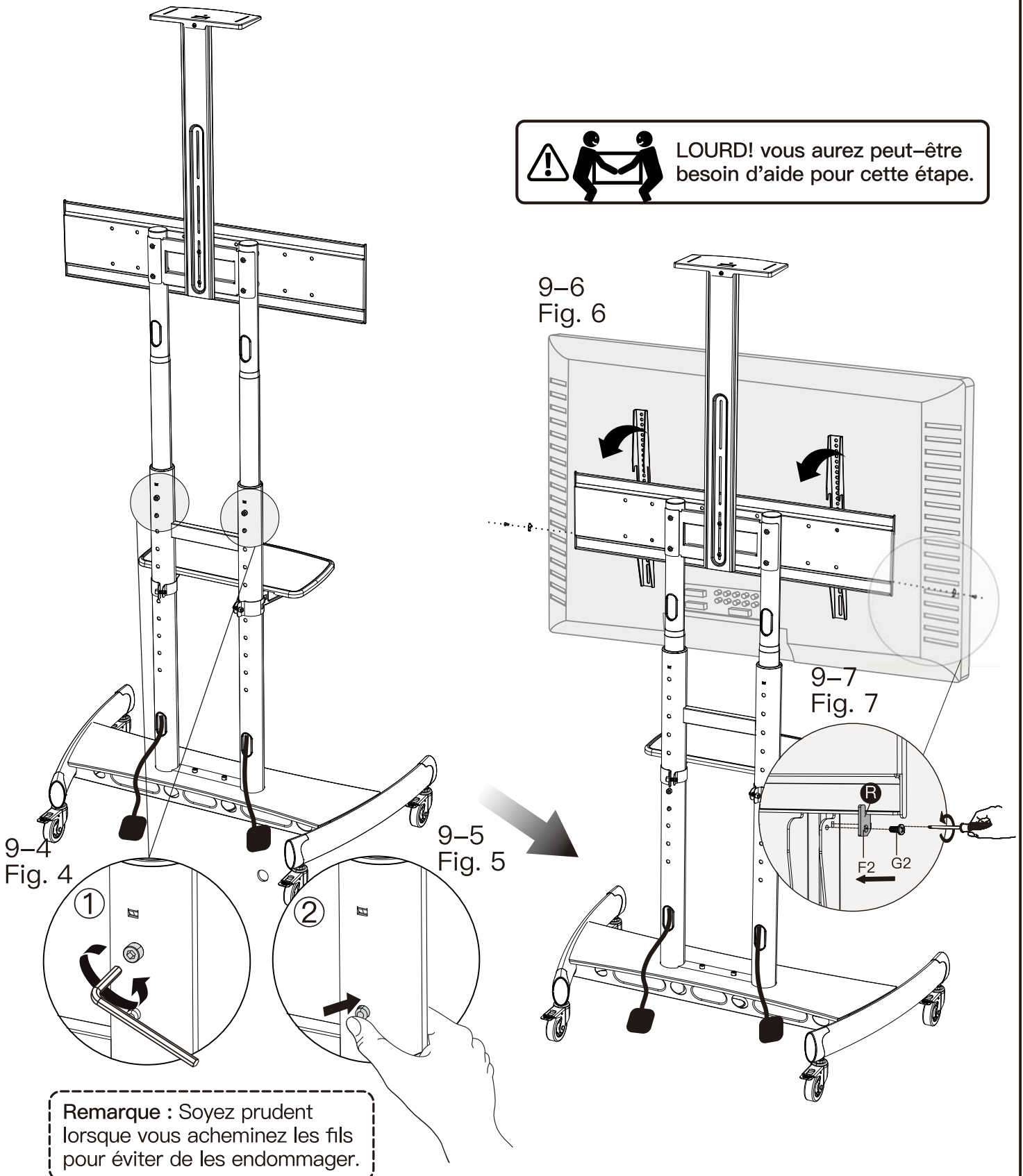

## INFORMACIÓN IMPORTANTE DE SEGURIDAD

**⚠ ¡PELIGRO!** Por favor, lea cuidadosamente todas las instrucciones antes de realizar la instalación. Si no entiende las instrucciones o tiene alguna duda o consulta, póngase en contacto con nuestra línea de asistencia técnica llamando al (877) 419-7832, o escribiendo al servicio de atención al cliente en [support@ergoav.com](mailto:support@ergoav.com).

**⚠ PRECAUCIÓN:** El uso con productos más pesados que los pesos máximos indicados puede causar inestabilidad causando posibles lesiones.

- No utilice este producto con ningún fin que no sea el especificado explícitamente en este manual.
- Utilice este sistema de montaje sólo para el uso previsto, tal como se describe en estas instrucciones. No utilice accesorios no recomendados por el fabricante.
- No lo utilice en el exterior. Este producto está diseñado para uso en interiores únicamente.
- No exceda el peso máximo que se indica en el manual de este producto. La sobrecarga de los carros de audio o video con equipos adicionales en lugares no especificados, puede provocar heridas grave, o incluso la muerte, debido al colapso del carro, la inestabilidad durante el movimiento o la posibilidad de que alguien tropiece.
- Coloque los cables de forma apropiada para evitar daños mecánicos.
- Se debe tener un cuidado especial siempre que se utilicen carros alrededor de los niños. Ciertos objetos, tales como controles remoto o juguetes colocados en el carro, pueden llamar la atención de los niños y hacer que se suban al carro y se caigan. Pueden producirse heridas graves o incluso la muerte si los niños trepan los carros de quipo de video y / o audio.
- No nos hacemos responsables de posibles daños o lesiones causados por un montaje incorrecto, errores de ensamblaje o uso inadecuado.

SAVE THESE INSTRUCTIONS.

Antes de iniciar el montaje, compruebe que todas las piezas estén incluidas e intactas. No use piezas dañadas o defectuosas. Si necesita piezas de repuesto, contáctese con nuestro soporte técnico al (877) 419-7832 o con atención al cliente en [support@ergoav.com](mailto:support@ergoav.com).

## Revise el patrón VESA de la TV antes de la instalación

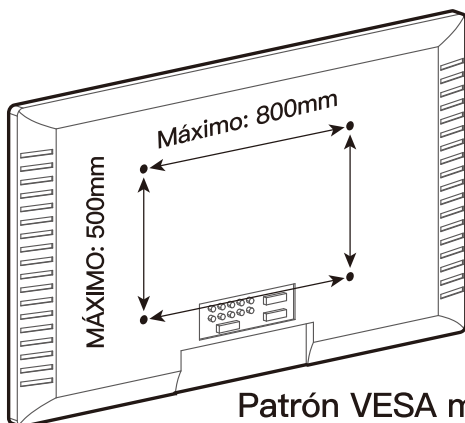

200mm ≈ 7 7/8 pulg	600mm ≈ 23 5/8 pulg
300mm ≈ 11 3/4 pulg	700mm ≈ 27 9/16 pulg
400mm ≈ 15 3/4 pulg	800mm ≈ 31 1/2 pulg
500mm ≈ 19 11/16 pulg	

Patrón VESA mínimo: 200mm x 200mm / 7 7/8 pulg x 7 7/8 pulg (Al. x An.)

Máximo: 800mm x 500mm / 31 1/2 pulg x 19 11/16 pulg (Al. x An.)

Este soporte **NO ES COMPATIBLE** con su Televisor si su patrón VESA de Televisor es menor a 200mm x 200mm o mayor a 800mm x 500mm. Contáctese con nuestro soporte técnico al (877) 419-7832 o en [support@ergoav.com](mailto:support@ergoav.com) para encontrar un montaje compatible.

## Límites de peso



Capacidad de peso máxima de bandeja superior: 10 lbs. (4,5 kg)



Peso máximo de Televisor: 200 lbs. (90 kg)



Capacidad máxima de peso del estante: 10 lbs. (4,5 kg)

**MÁXIMO**  
Soporte para TV  
200 lbs. / 90 kg

**MÁXIMO**  
Estante del  
10 lbs. / 4,5 kg

**MÁXIMO**  
Bandeja superior  
10 lbs. / 4,5 kg

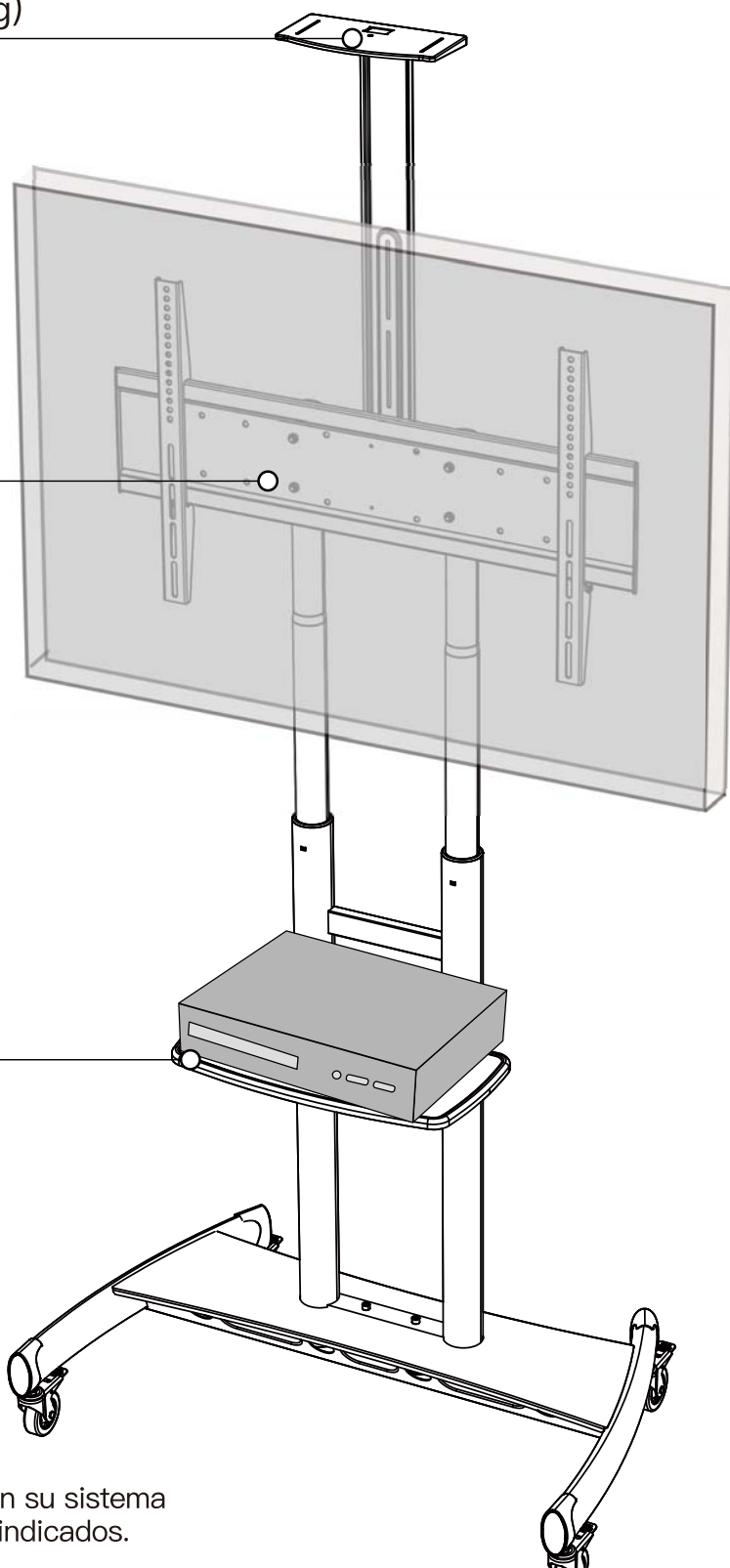

**!** Este carrito de Televisor no es compatible con su sistema si sus productos superan los límites de peso indicados.

### **!** ADVERTENCIA

NO exceda el peso máximo indicado. Este sistema de soporte solo se puede usar dentro del rango de peso indicado. Es posible que el soporte falle si lo usa con productos que excedan el límite de peso máximo, provocando potencialmente daños o lesiones.

## Herramientas necesarias (no incluidas)



## Piezas y herrajes suministrados para el paso 1

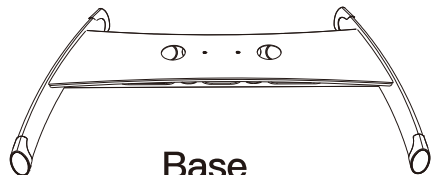

Base

**01** x 1

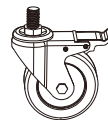

Rueda

**02** x 4

## Paso 1 Agregar las ruedas a la base

1-1 Voltee la base [01] de manera que la parte inferior de la base [01] quede hacia arriba.

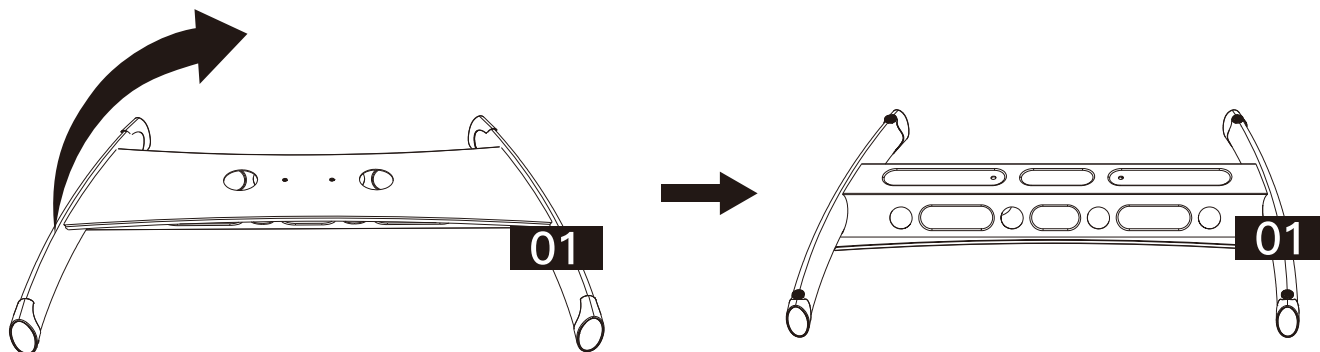

1-2 Coloque la pestaña de bloqueo hacia abajo para cerrar la rueda [02].  
Atornille las ruedas [02] dentro de la base [01].

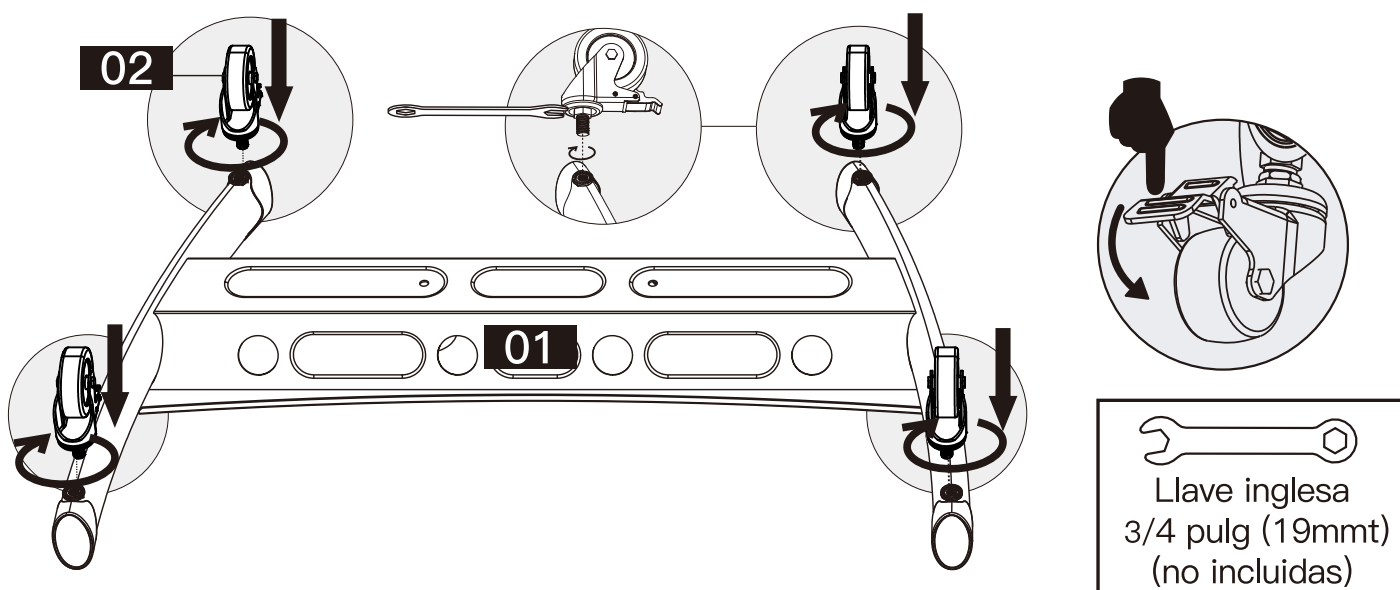

Desbloqueo

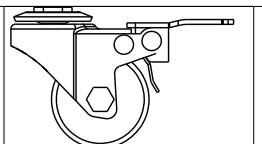

Bloqueado

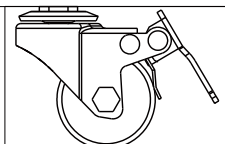

**Nota:** Para evitar el movimiento de las ruedecillas [02] mientras se monta, bloquee las mismas.

## Piezas y herrajes suministrados para el paso 2

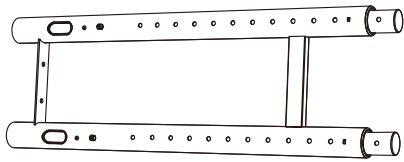

Poste con altura ajustable

**03** x 1



Perno  
M8 X 20mm  
A2 x 4



Llave Allen  
M6  
E2 x 1

## Paso 2 Conectar el ensamblaje de poste a la base

2-1 Coloque el poste de altura ajustable [03] dentro de la base [01] como se muestra abajo. Coloque dos pernos [A2] por el poste de altura ajustable dentro de la base [01].

2-2 Coloque los dos pernos restantes [A2] por la base [01] y dentro de los insertos roscados de la parte inferior del poste de altura ajustable [03].

Ajuste todos los cuatro pernos [A2] con una llave Allen [E2] hasta que queden bien fijados.

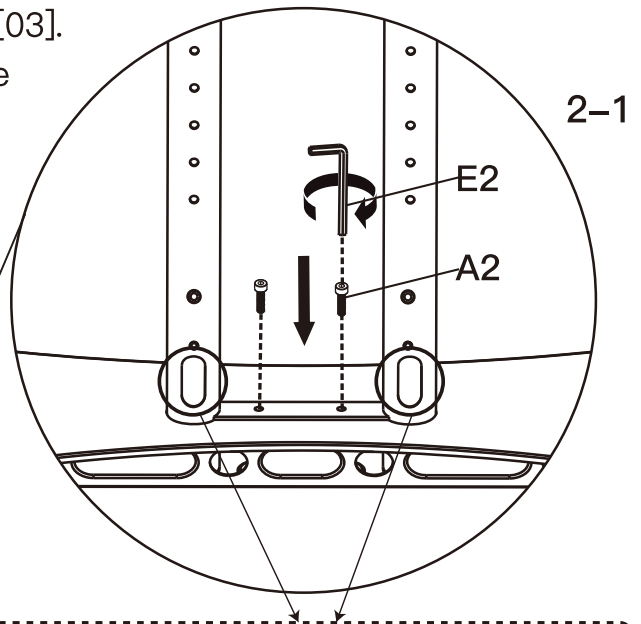
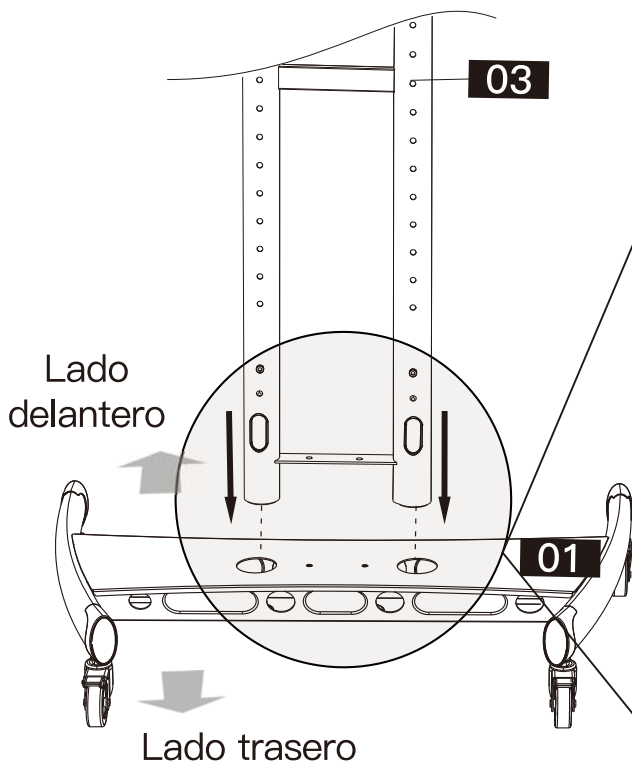

**Nota:** Asegúrese de que las entradas de manejo de cables estén apuntando hacia la parte trasera de la base.

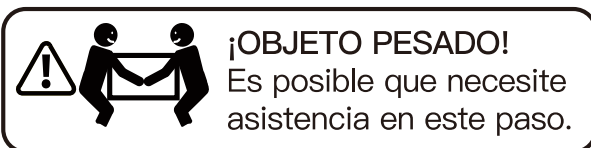
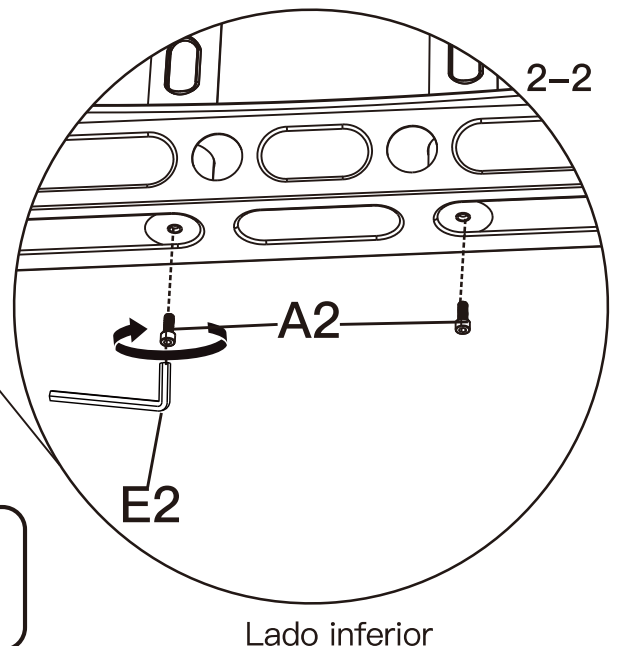

## Paso 3 Ajustar la altura del poste

3-1 (Fig. 1) Destornille el perno de seguridad ya montado [S2] de los postes inferiores derechos de montaje con una (llave Allen de 6mm) [E2] y guárdela para usarla en el paso 3-4.

3-2 (Fig. 2) Use su pulgar izquierdo o el dedo índice para oprimir la pelota de resorte [S1] del poste inferior derecho (Cerca de la entrada de cable), al mismo tiempo use su mano derecha girar y tirar el poste superior derecho (A sentido horario o antihorario) hacia arriba a la altura que desee.

3-3 (Fig. 3) Use la etiqueta del indicador de altura del poste como guía. Luego gire el poste superior hacia los agujeros de émbolo y la pelota de resorte fijada [S1] dentro del agujero de émbolo.

3-4 (Fig. 4) Use una (llave Allen de 6 mm) [E2] para ajustar bien el perno de seguridad [S2].

**NOTA:** Realice los procedimientos de los pasos 3-1 a 3-4 para quitar el poste superior izquierdo.

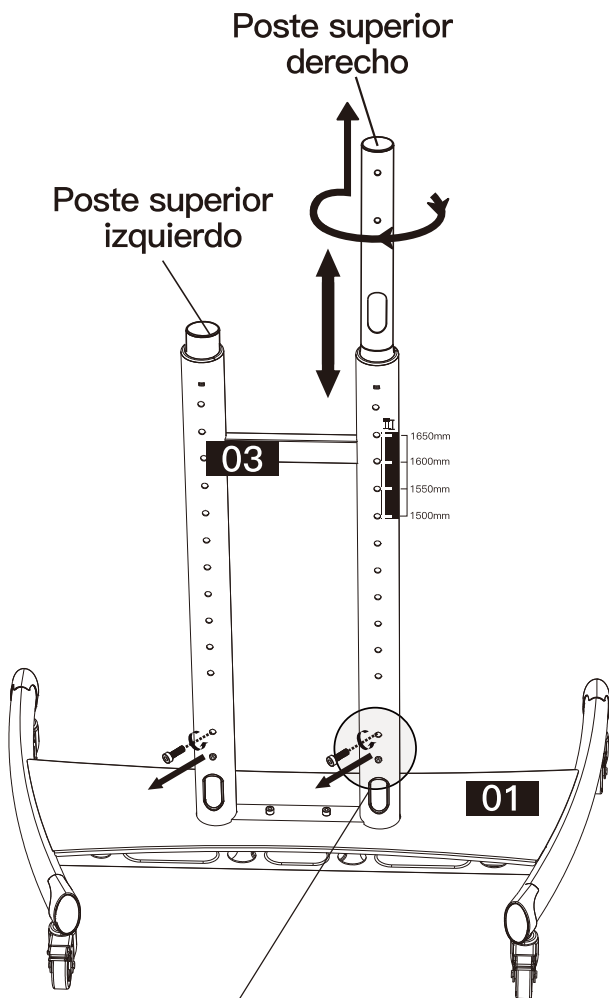

Fig. 1

Fig. 2

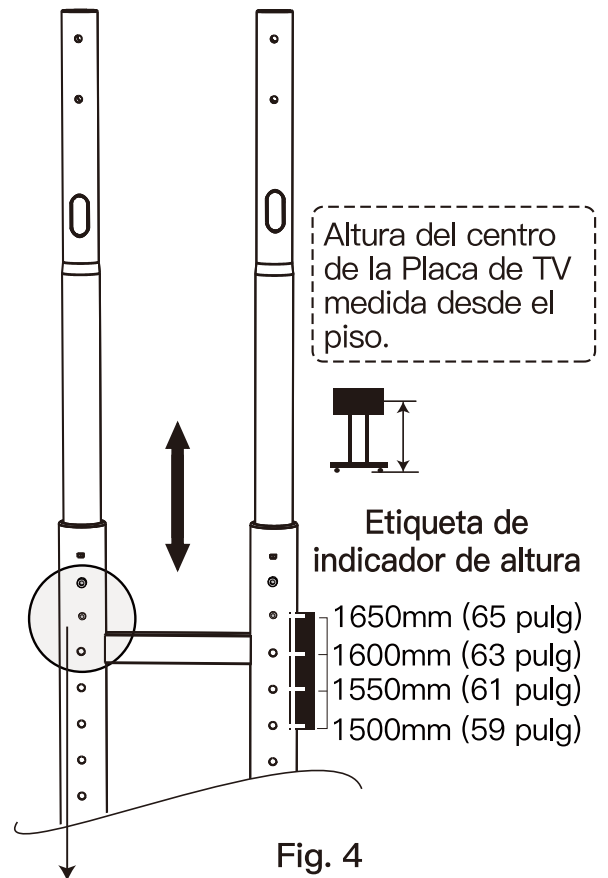
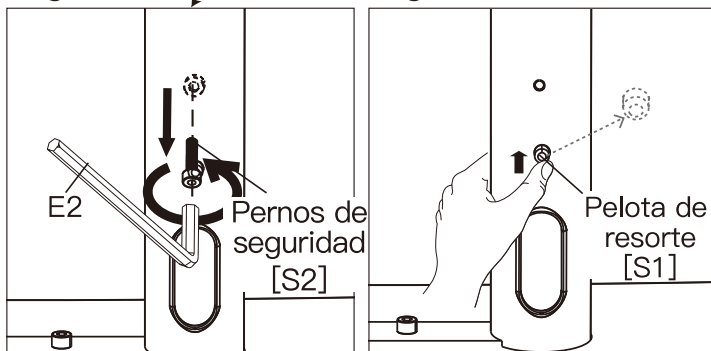
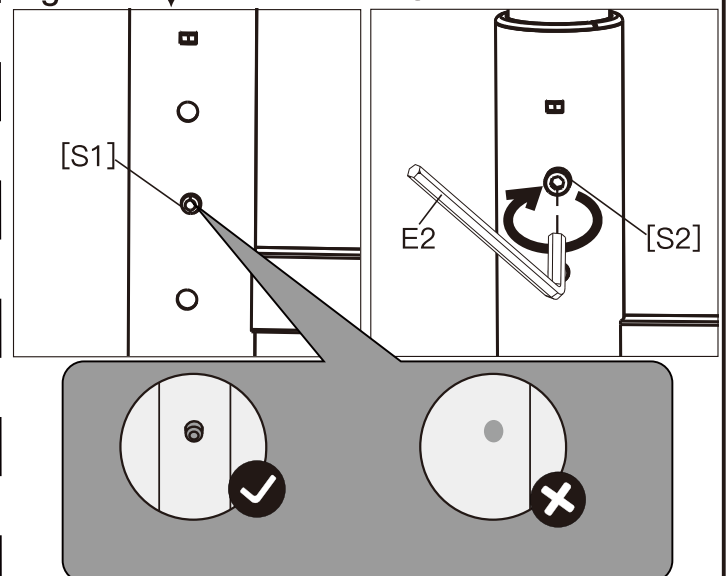

Fig. 3

Fig. 4





# Piezas y herrajes suministrados para el paso 4

Cubierta de cables	Placa de TV	Placa de conexión	Perno M8 X 72mm	Espaciadores L13mm	Llave Allen M6
<b>04</b> x 2	<b>05</b> x 1	<b>06</b> x 1	B2 x 4	D2 x 4	E2 x 1

## Paso 4 Ajuste la Placa de Conexión y la placa de TV en el poste de altura ajustable.



Fije las cubiertas de cables [04]. Coloque los pernos [B2] por la Placa de Conexión [06], los postes superiores, espaciadores, [D2] y la placa de TV [05]. Ajuste bien con una llave Allen [E2].

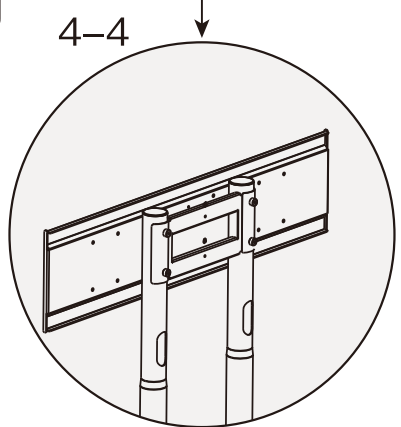
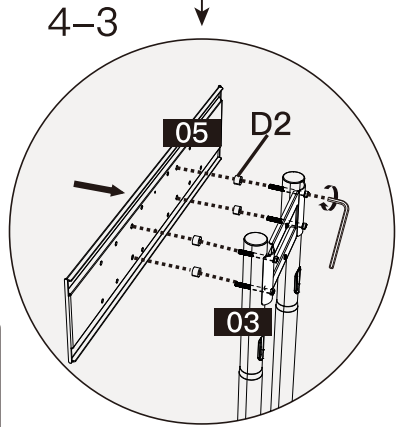
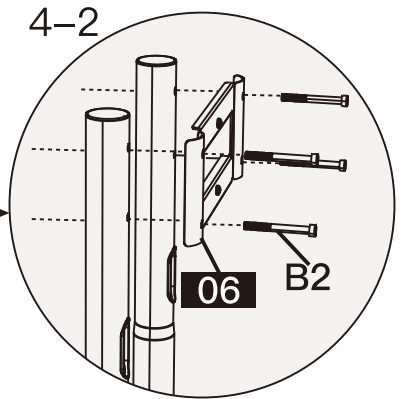
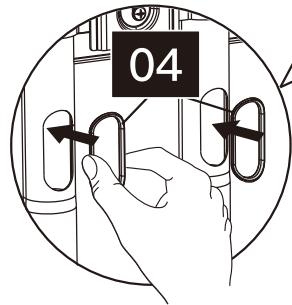
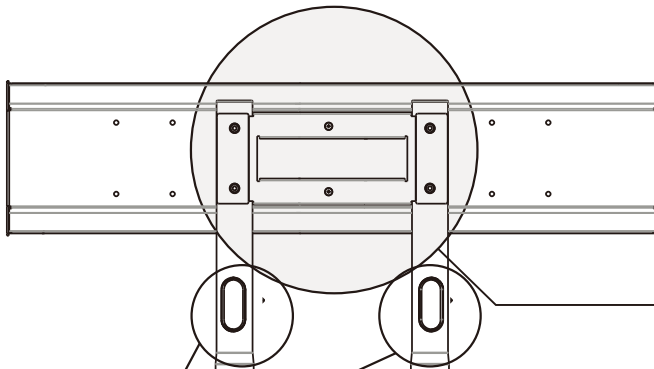

**¡OBJETO PESADO!**  
Es posible que necesite asistencia en este paso.

**Precaución:** Asegúrese de que los pernos estén bien ajustados.

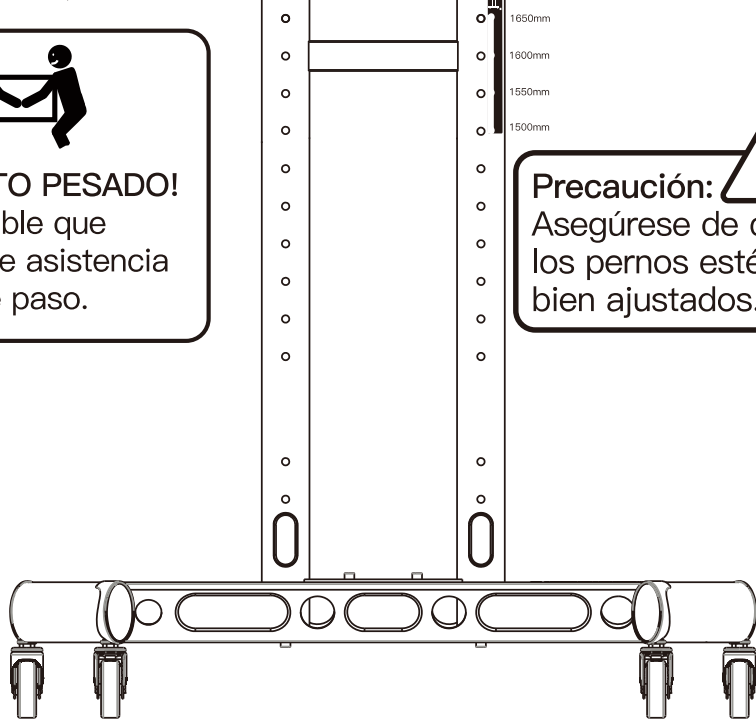

# Piezas y herramientas suministrados para el paso 5

Nota: Las ilustraciones muestran el verdadero tamaño de las arandelas, y espaciadores.

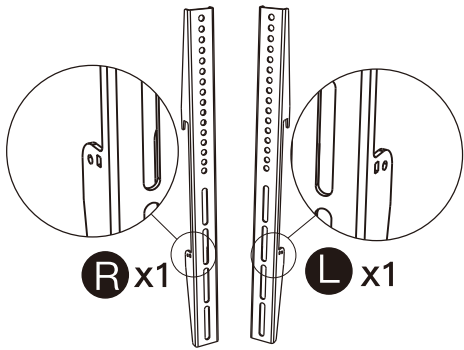

Soporte para TV

**07**

## Arandelas

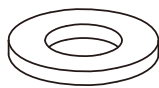

M4 / M6  
H1 x 4

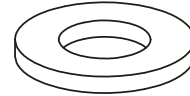

M8  
H2 x 4

## Espaciadores [ Si es necesario ]

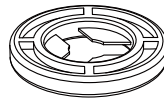

L2.5mm  
I x 8

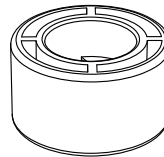

L10mm  
J x 4

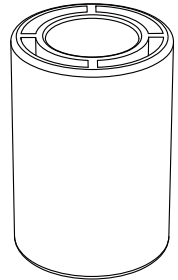

L23mm  
K x 4

## Perno TV

[ Solo un tamaño de perno encaja en su Televisor ]

Nota: Los pernos se muestran en tamaño real

**M4**



M4 x 30mm  
[A] x 4

**M6**

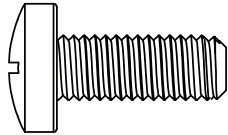

M6 x 16mm  
[B] x 4

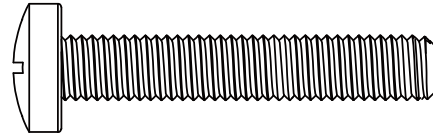

M6 x 35mm  
[C] x 4

**M8**

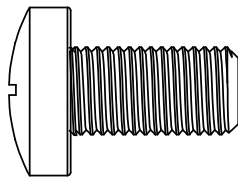

M8 x 15mm  
[D] x 4

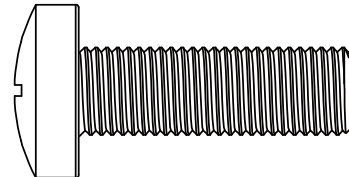

M8 x 25mm  
[E] x 4

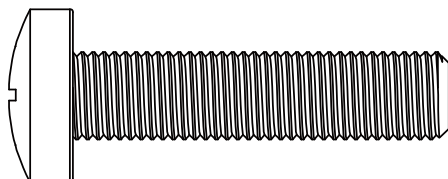

M8 x 35mm  
[F] x 4

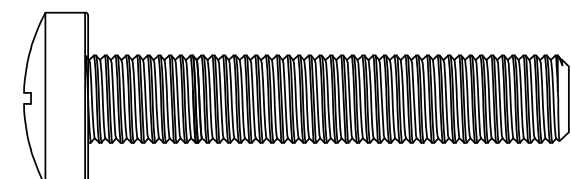

M8 x 50mm  
[G] x 4

## Paso 5 Asegurar los soportes para Televisor al Televisor

### Seleccione los perno para el TV

Su televisor solo admite uno de los tamaños de perno.

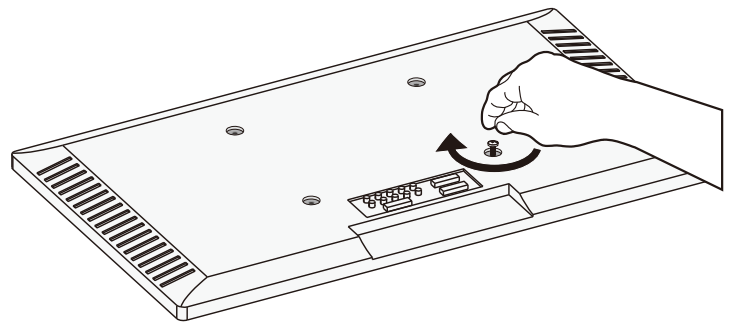
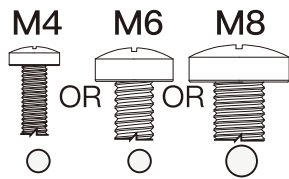

Longitud del perno: Compruebe que la rosca encaje correctamente con los pernos o la las combinaciones de pernos / espaciador. Se recomienda enganchar las roscas con 5 vueltas como mínimo.

- Si es demasiado corto, no soportará el TV.
- Si es demasiado largo, hará daños al TV.

**NOTA:** No ajuste los pernos del televisor en exceso para no dañarlo.

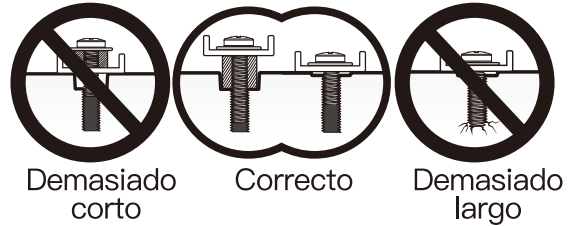

**Nota:** Al utilizar espaciadores, es importante tener en cuenta que se pueden utilizar apilados. Si tiene alguna dificultad para comprender el modo de instalación de los pernos o espaciadores del televisor, póngase en contacto con nuestra línea de asistencia técnica al (877) 419-7832 o con el servicio de atención al cliente en [support@ergoav.com](mailto:support@ergoav.com).

### Piezas necesarias si tiene un televisor como el que se muestra a continuación

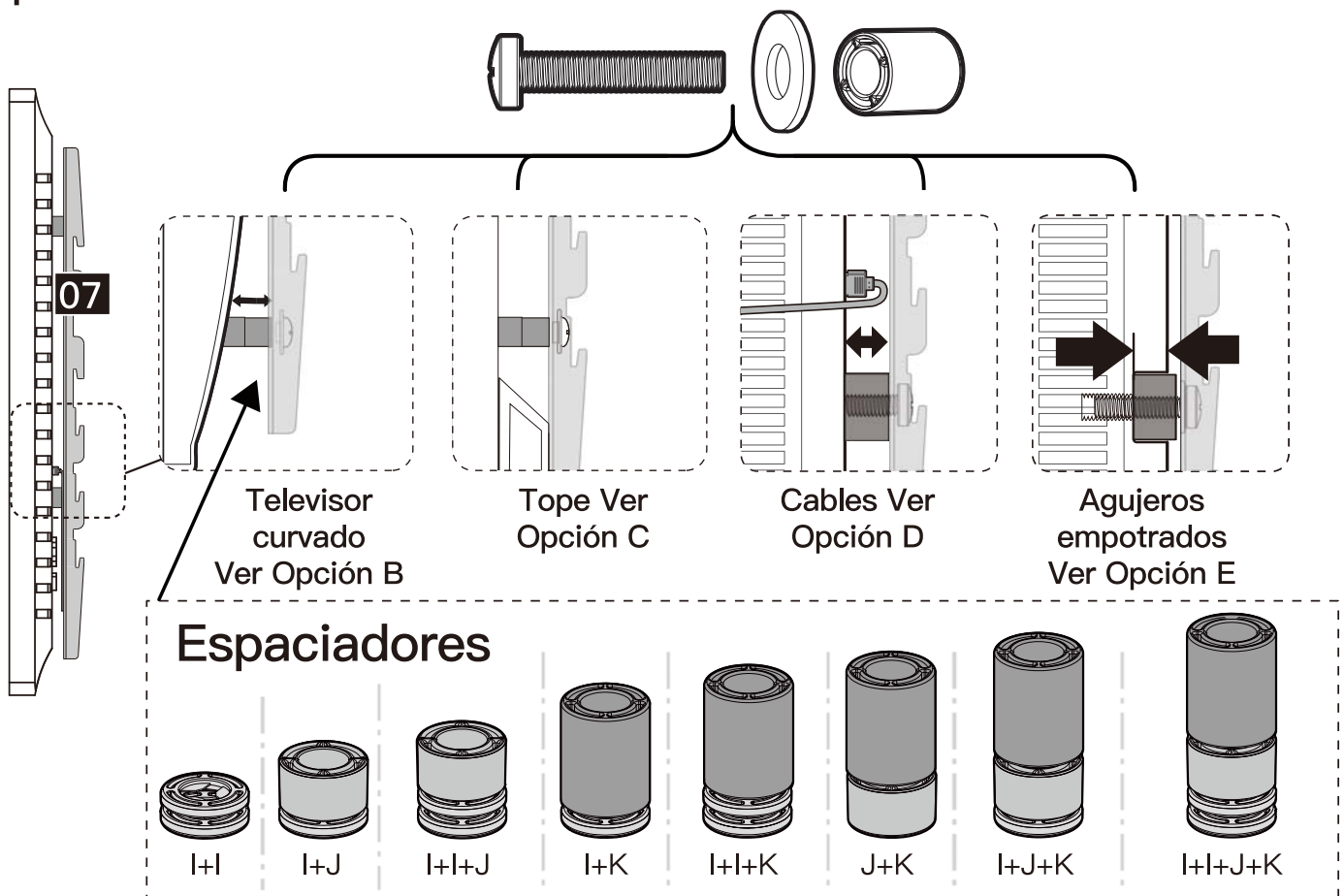

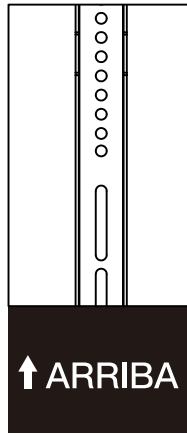
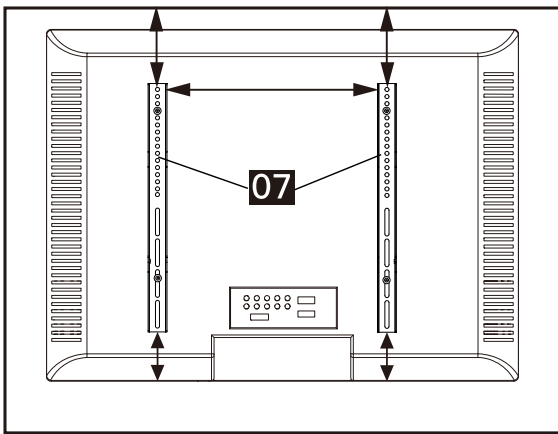

**⚠ PRECAUCIÓN:** Al fijar los soportes para TV [07] a la parte trasera del Televisor, asegúrese de que los extremos con agujeros apunten hacia la parte superior del Televisor y estén centrados de igual manera en la parte trasera del Televisor.

**⚠ NOTA:** Las ubicaciones de los agujeros para perno de su televisor pueden variar según el diseño del televisor de los fabricantes. Solo ilustramos algunas ubicaciones posibles de dichos agujeros de los pernos.

### Opción A (Para televisores con la parte trasera plana)

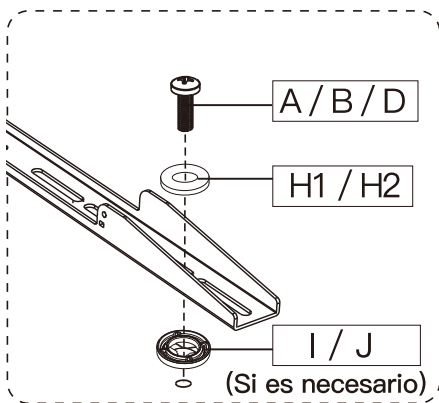

Consulte las instrucciones sobre los espaciadores en la página 41, de ser necesario.

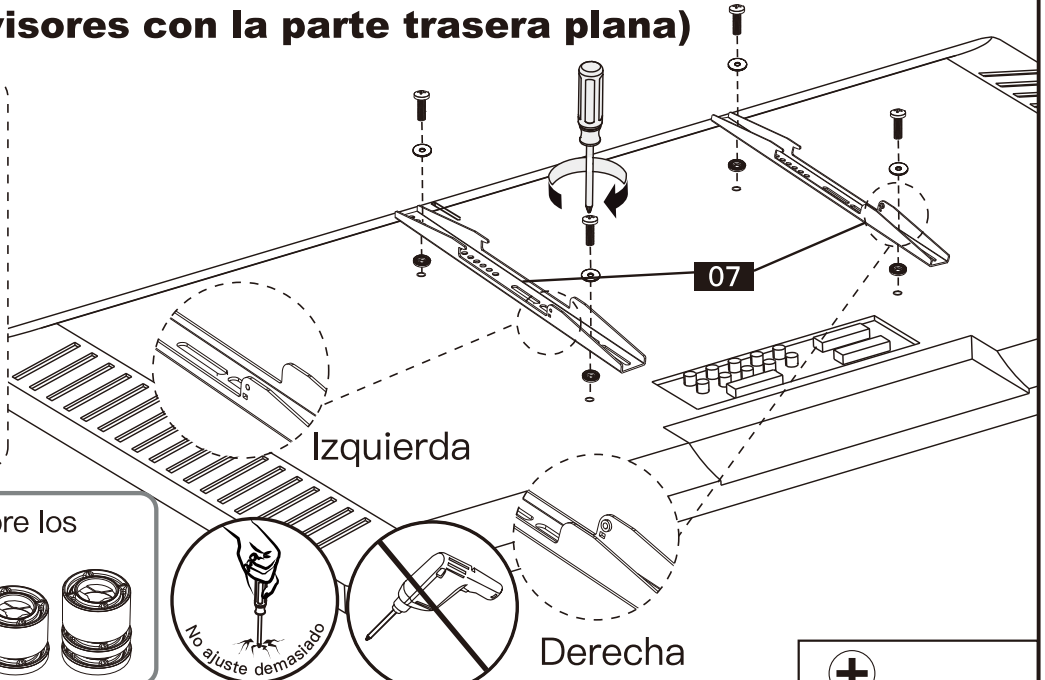
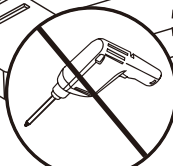

**+**  
Destornillador Philips  
(No se incluye)

### Opción B (Para televisores con la parte trasera redondeada)

Los espaciadores deben ser lo suficientemente altos para que la curva de la parte posterior del televisor no interfiera con la placa de montaje.

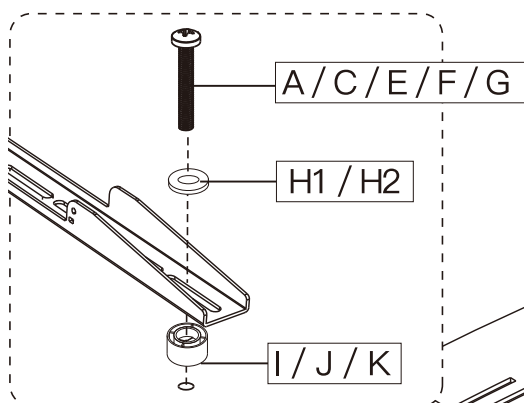

Consulte las instrucciones sobre los espaciadores en la página 41, de ser necesario.

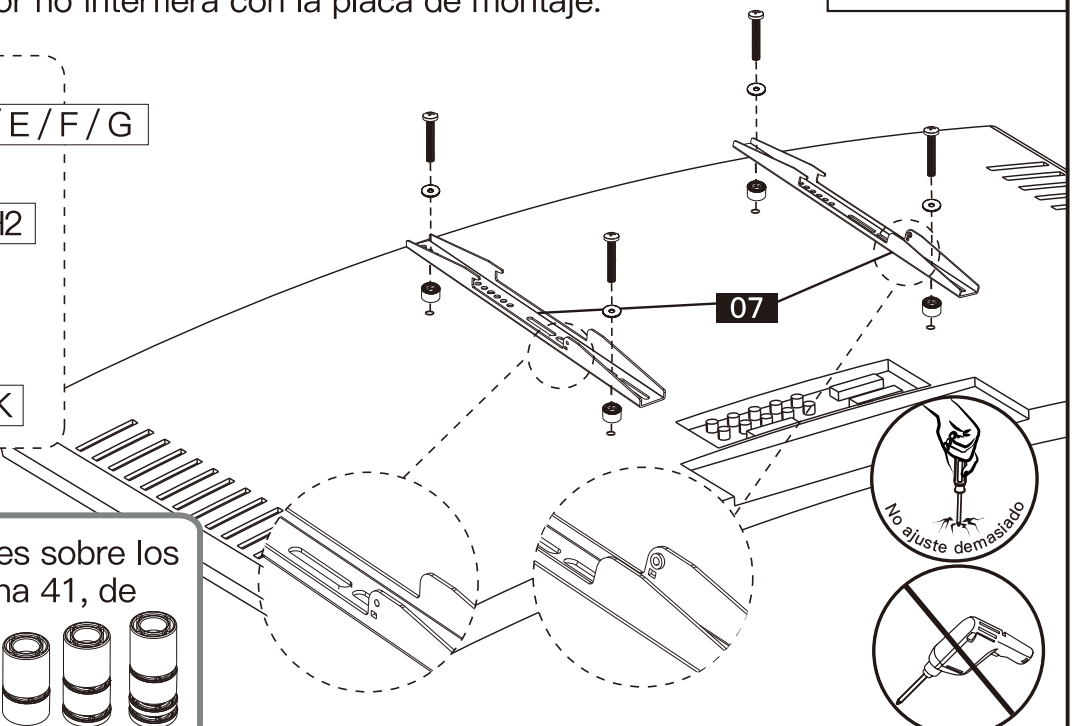
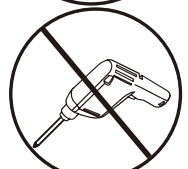

### Opción C (Para televisores con parte trasera saliente)

Los espaciadores deben ser los suficientes altos para que no exista una brecha entre el soporte de TV y el tope de retención de la parte trasera del Televisor.

  
Destornillador  
Phillips  
(No se incluye)

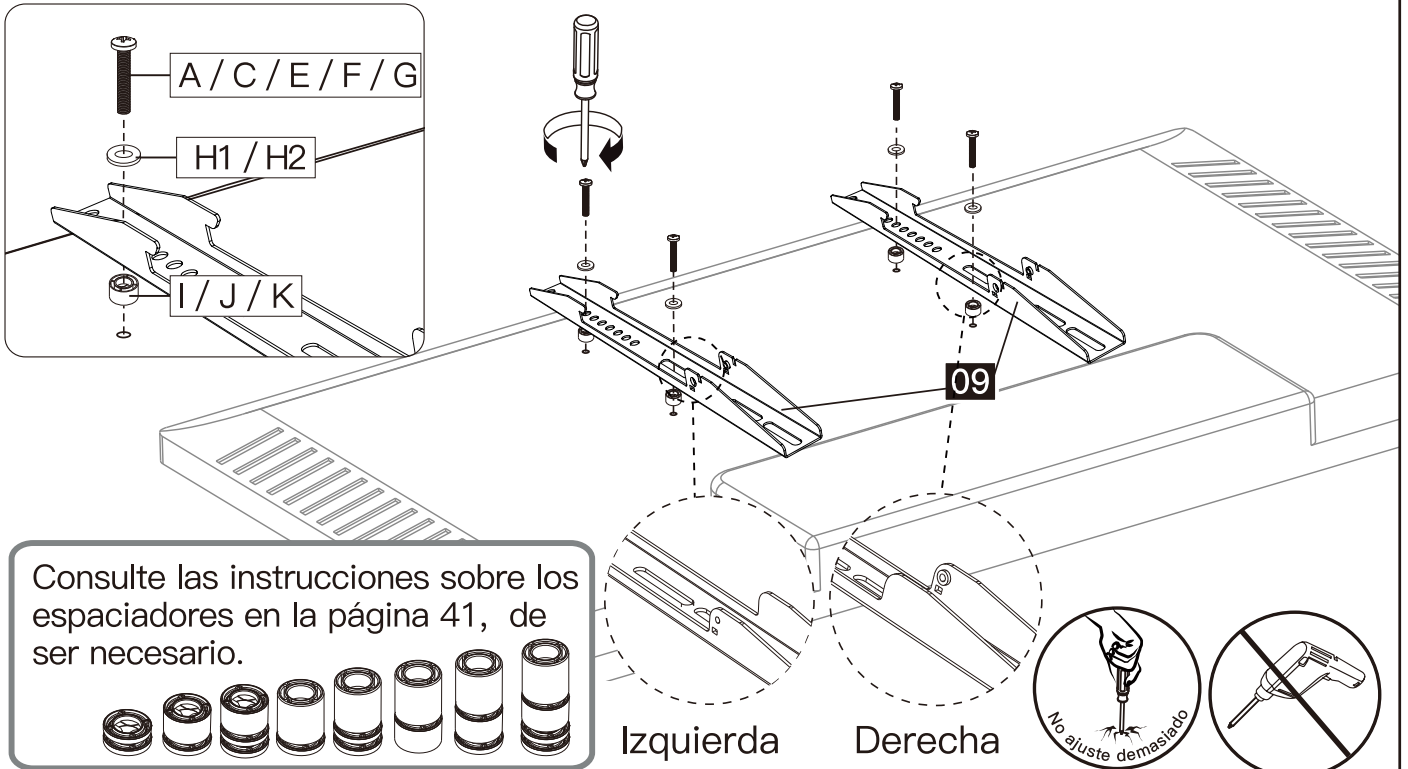

### Opción D (Para televisor con interferencia de cables)

Para la interferencia de cables, utilice los espaciadores [I], [J] y [K] para crear un espacio extra entre el televisor y los soportes para TV.

  
Destornillador  
Phillips  
(No se incluye)

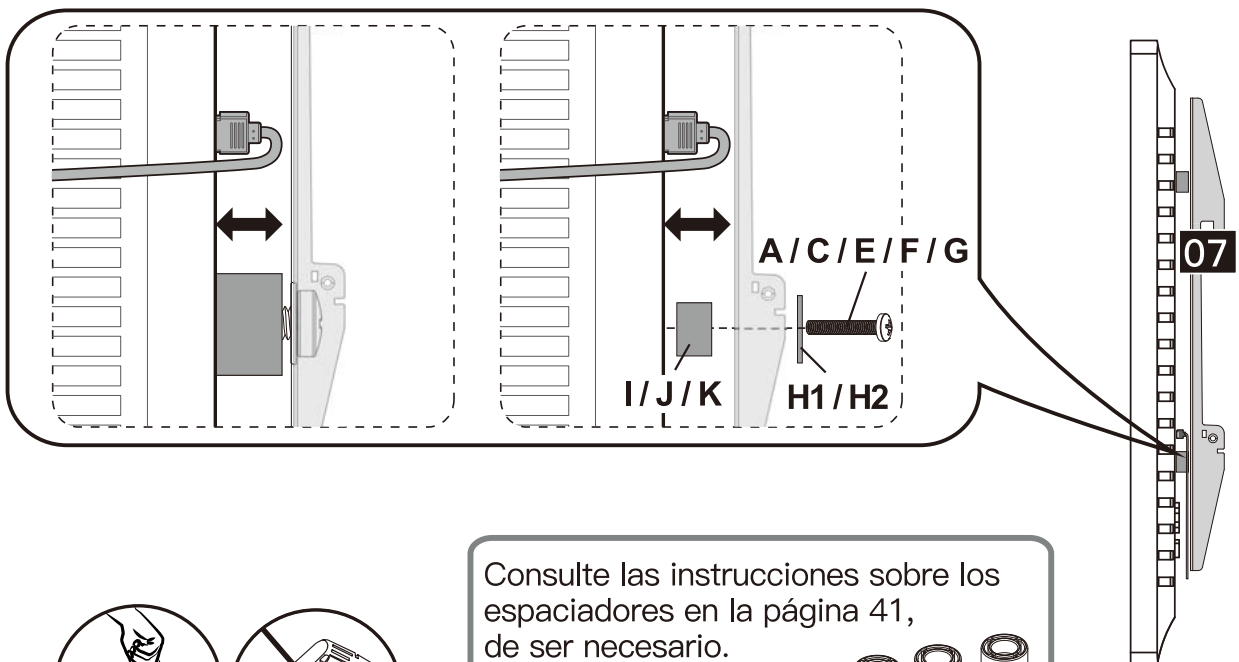



## Opción E (Para agujeros empotrados)

Los espaciadores [I], [J] y [K] deben rellenar los agujeros empotrados de la base del Televisor para que los soportes para TV estén lo más cerca posible del Televisor.



Destornillador Philips  
(No se incluye)

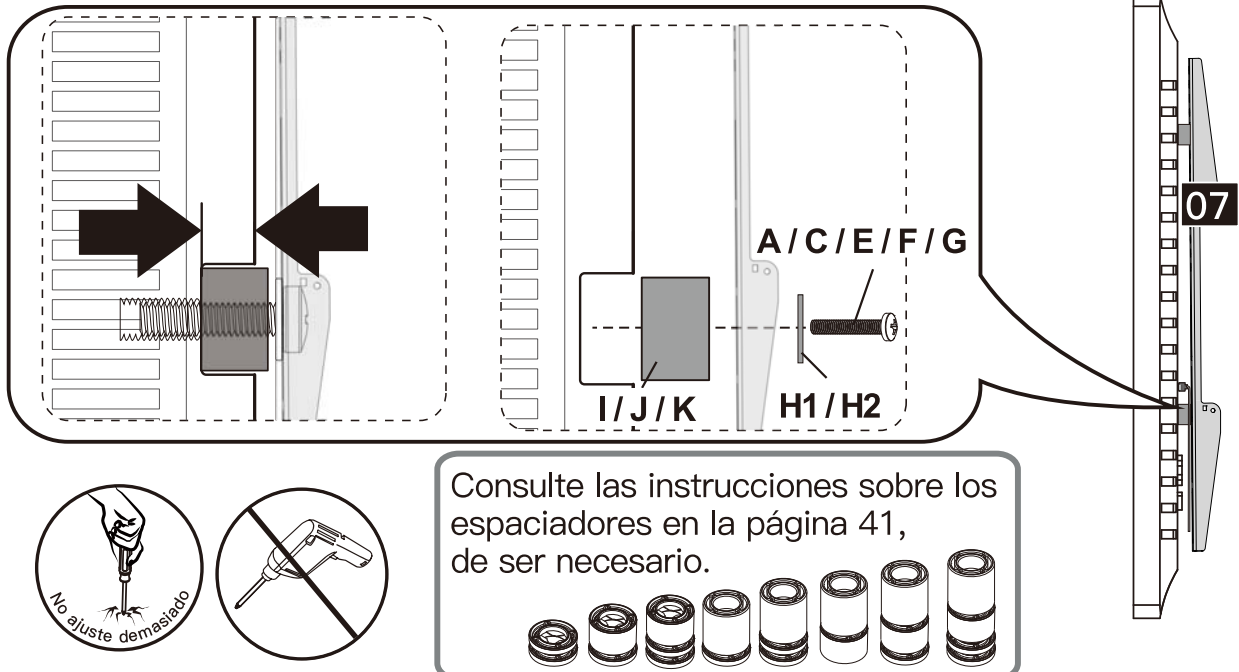

## Piezas y herrajes suministrados para el paso 6

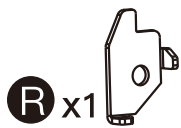

Cerradura de seguridad  
F2



Perno  
M5 x12mm  
G2 x 2

## Paso 6 Colgar el Televisor en la placa de TV

6-1 Cuelgue el Televisor con los soportes para TV [07] en la placa de TV [05].

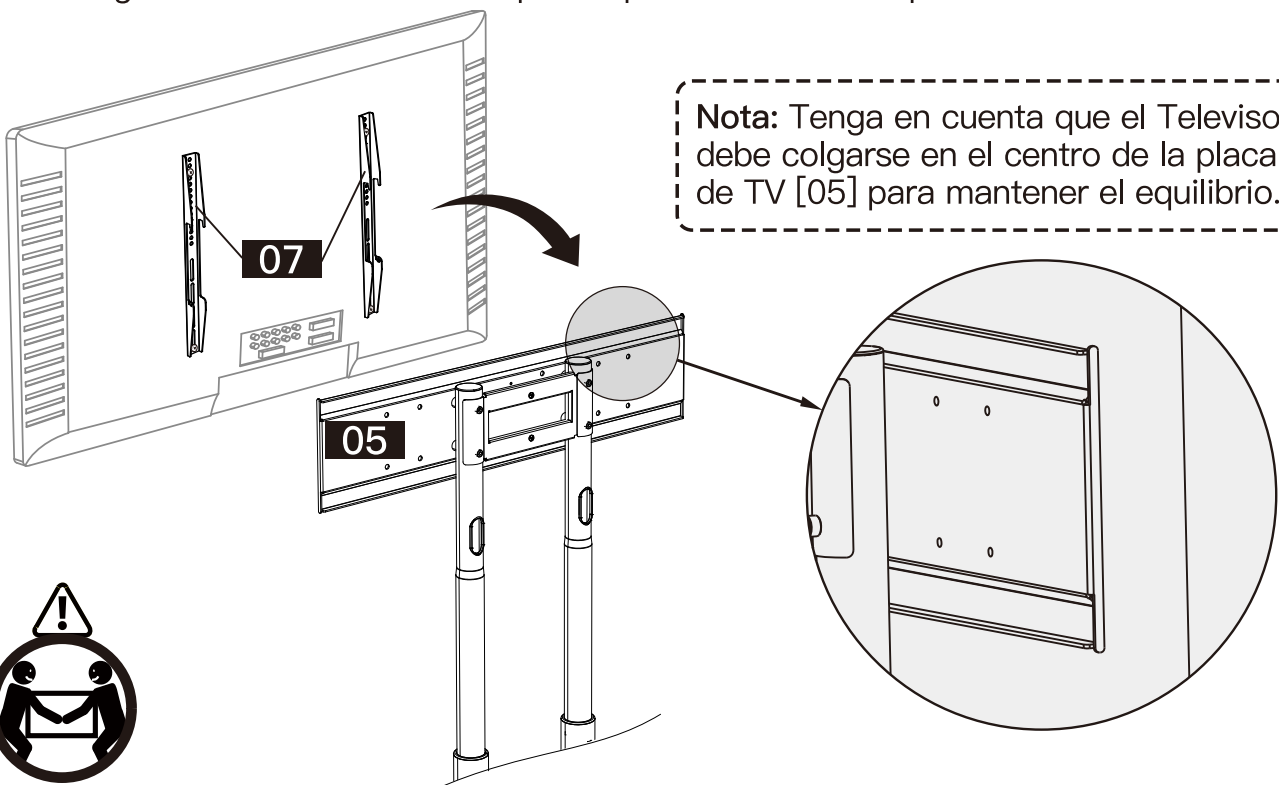



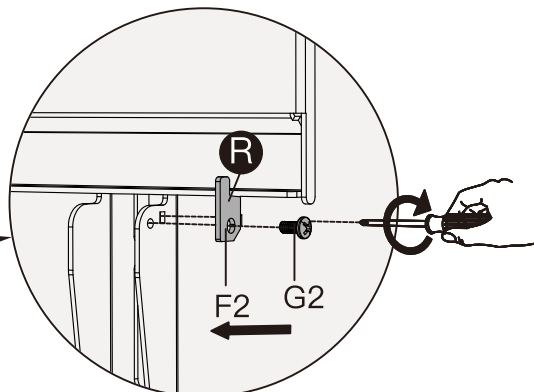
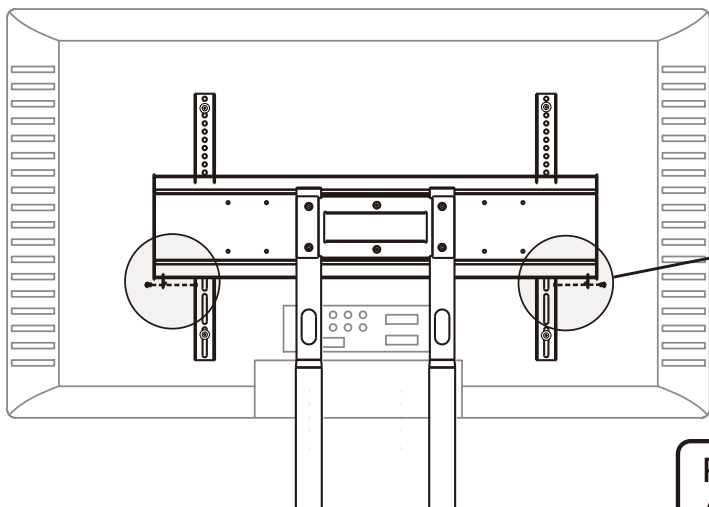

6-2 Coloque los pernos [G2] por las cerraduras de seguridad [F2] y enrósquelos dentro del soporte para TV [07]. Ajuste con un destornillador Phillips.

**Nota:** Mueva el Televisor hacia el centro.



**Precaución:**  Asegúrese de que los pernos estén bien ajustados.

 Tournevis Phillips (Non inclus)

## Las piezas proporcionadas y el hardware para el paso 7

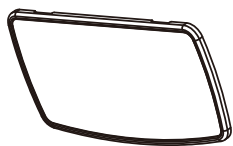

Estante AV  
**08** x 1

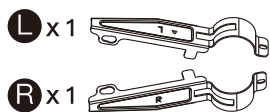

Soporte de estante AV  
**09**



Anillo  
**10** x 2



Perno M8 X 20mm  
A2 x 2



Llave Allen mediana M6  
E2 x 1

## Paso 7 Fijar la bandeja AV al poste de altura ajustable

**7-1-1**

Alinee los agujeros en los soportes de estante [09] con los topes de retención en la parte inferior del estante AV [08].

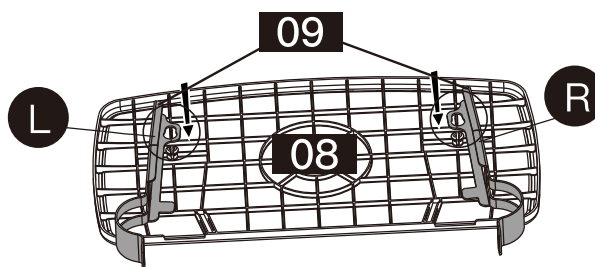

**7-1-2**

Tire el soporte de estante [09] hacia la parte trasera del estante AV [08] hasta que el soporte de estante [09] quede fijado dentro del tope de retención del estante AV [08]. Mueva los extremos de cada soporte de estante [09] hacia el centro hasta que las pestañas del soporte de estante AV [09] queden bien colocadas dentro de las ranuras del estante AV [08].

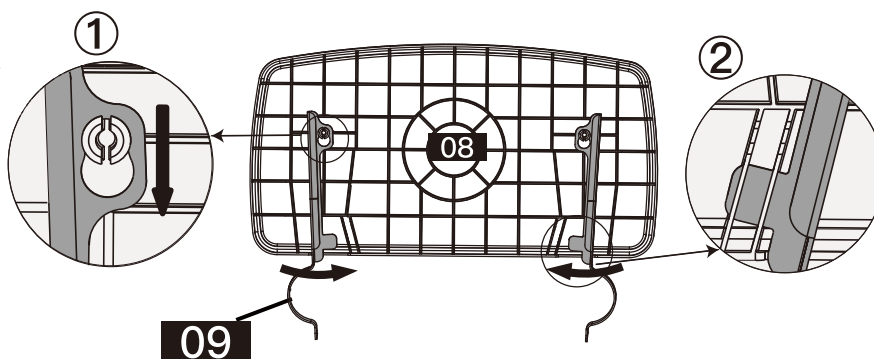

**7-1-3** Coloque el anillo [10] dentro de cada uno de los soportes de estante AV [09].

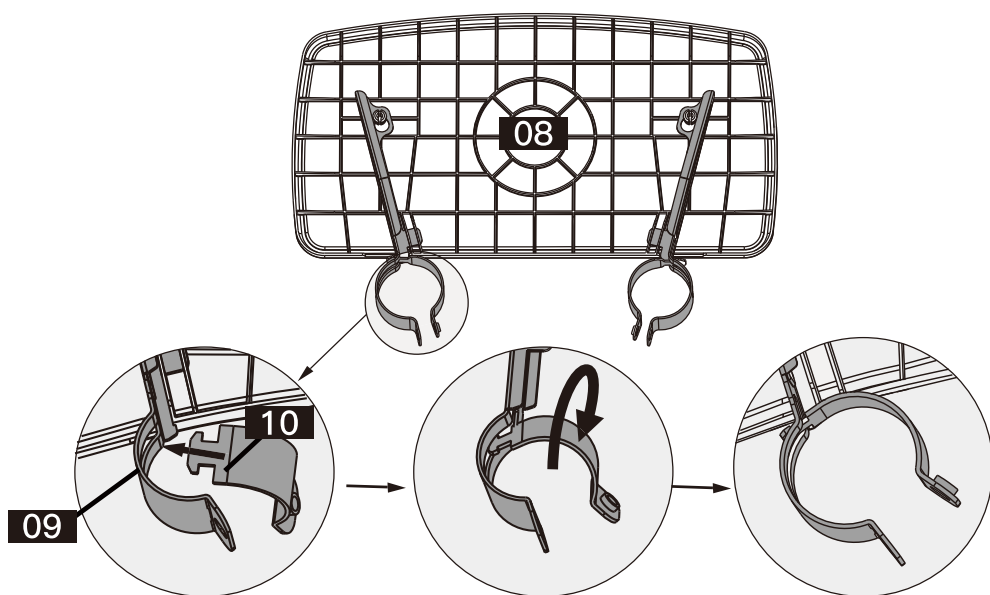

**7-2-1** Coloque el ensamblaje del estante AV en el poste de altura ajustable [03].

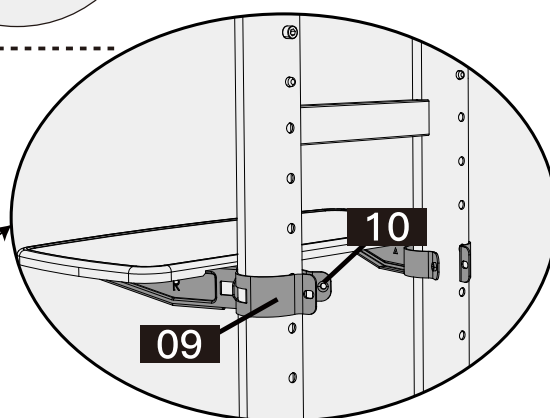
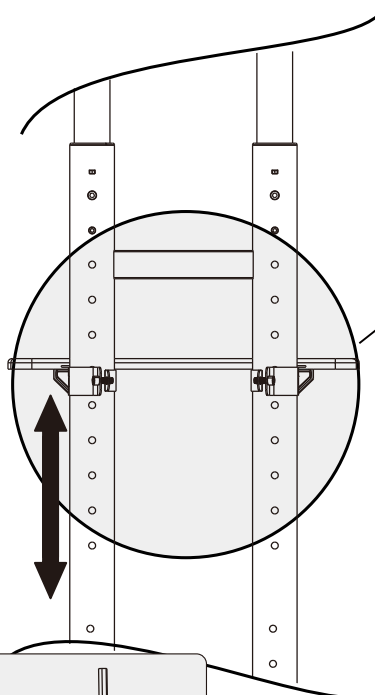

**7-2-2** Use una llave Allen [E2] para ajustar los pernos [A2] y fijar el montaje de estante AV al poste de altura ajustable [03].

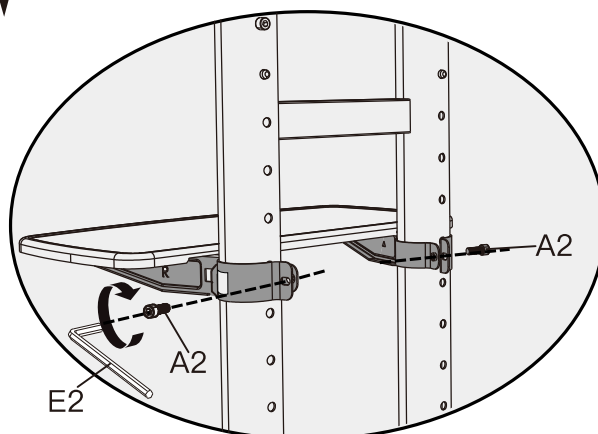

### Piezas proporcionadas y hardware para el paso 8-9



Soporte de bandeja de vídeo

**11** x 1



Bandeja de vídeo

**12** x 1



Perno  
M5 x10mm  
C2 x 1

## Paso 8 Instale el soporte de bandeja de vídeo en la placa conectora

8-1 Use un perno [C2] para asegurar la bandeja de vídeo [12] en la parte superior en el soporte de bandeja de vídeo [11].

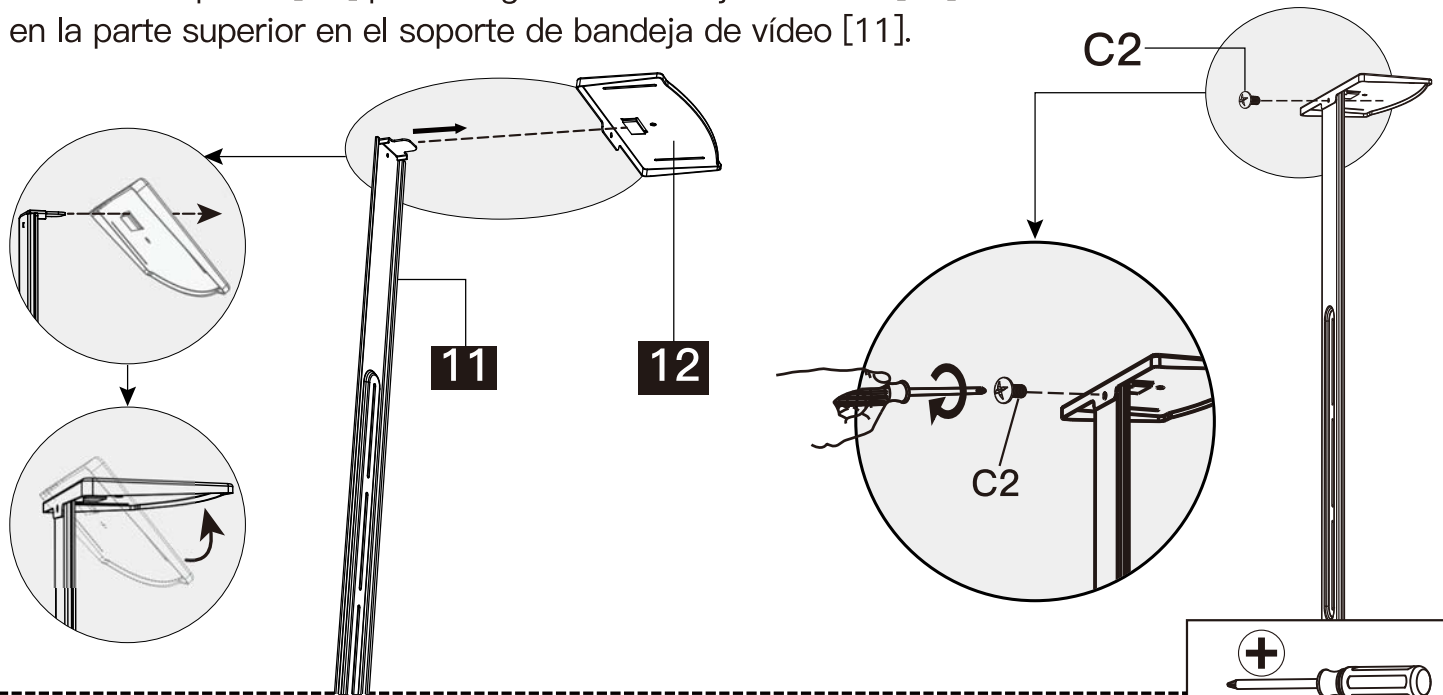

8-2 Retire los pernos ya montados [S3] de la Placa de Conexión [06] y guárdelos para usarlos en el paso 8-3.

8-3 Fije el soporte de bandeja de vídeo [11] en la Placa de Conexión [06] y ajuste con los pernos ya montados [S3].

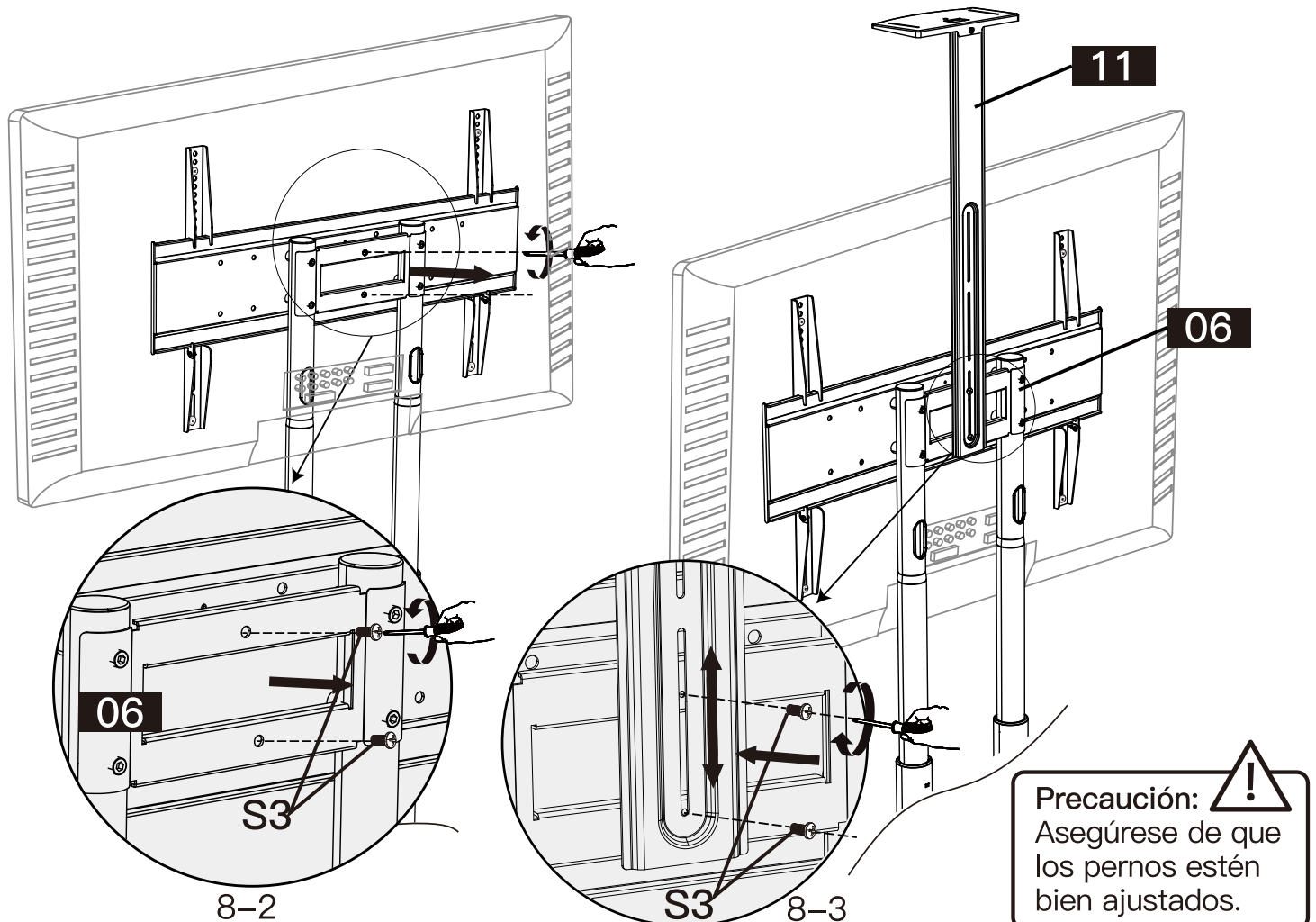

## Paso 9 Ajuste de altura de Televisor y la gestión de cables (Opcional)

**⚠ ADVERTENCIA:** Si ajusta la ubicación de la altura de Televisor con el Televisor conectado al carrito de Televisor pueden provocarse lesiones personales y / o daños materiales. Incluso con más de 1 persona, nunca intente ajustar la altura del Televisor mientras el Televisor está conectado al carrito de Televisor.

Si se determina que es necesario ajustar la altura del televisor, se puede ajustar siguiendo los pasos que se indican a continuación.

9-1 (Fig.1) Retire todos los cables del Televisor y desconecte el cable de alimentación del mismo.

9-2 (Fig.2) Retire el perno [G2] y los cierres de seguridad [F2] del lateral de los soportes para TV [07].

9-3 (Fig. 3) Con cuidado vuelva a colgar el televisor con los soportes en la placa de TV [05]. Coloque el Televisor en una zona segura y alejada.

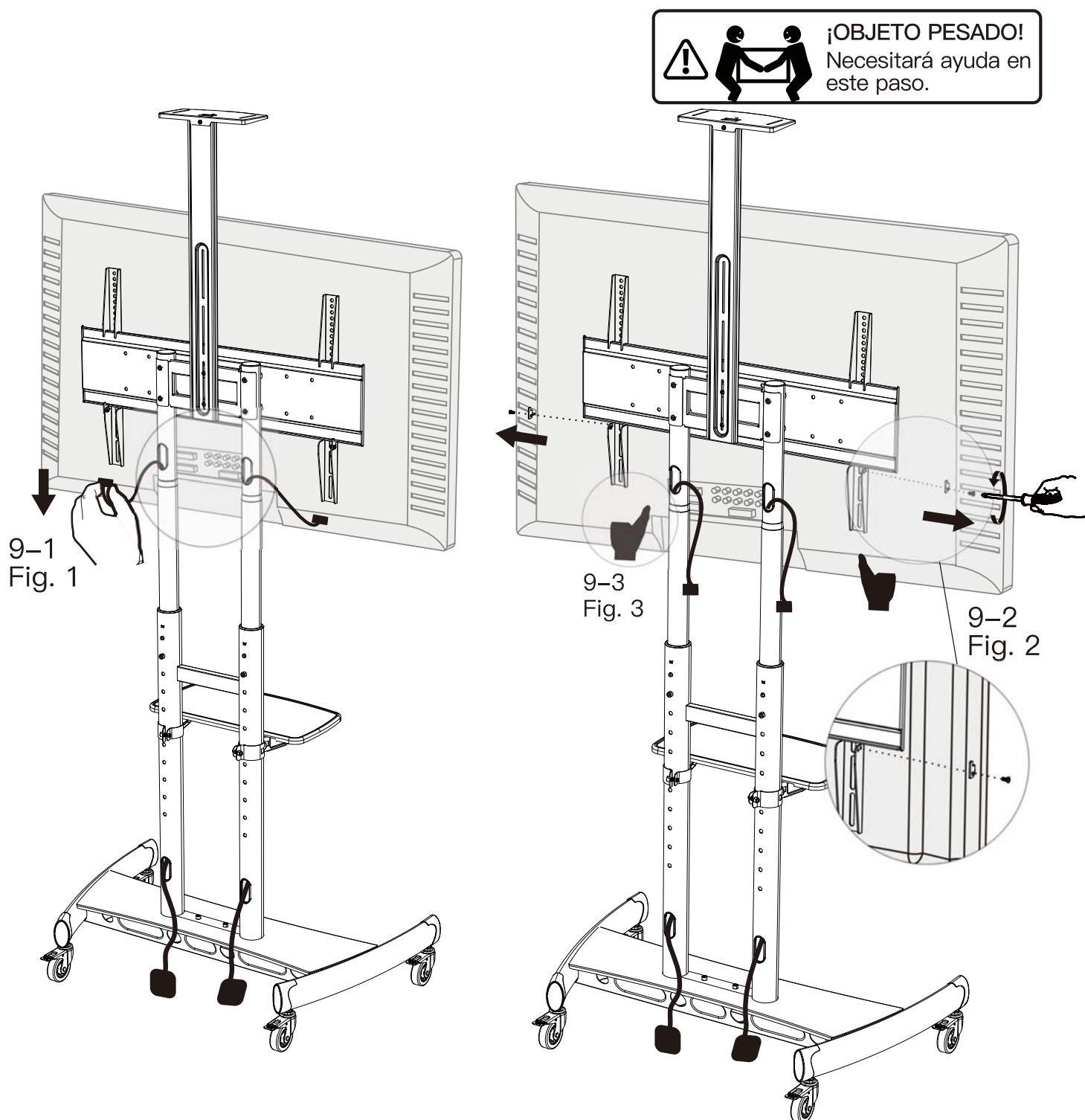

9-4 (Fig. 4) Retire los pernos de seguridad [S2] al poste de ajuste. Use las pelotas de resorte de cada poste de ajuste para volver a establecer la Placa de TV a la altura que desee.

9-5 (Fig. 5) Asegúrese de que las pelotas de resorte de ambos lados estén bien fijadas dentro del agujero de los postes de altura ajustables.

9-6 (Fig. 6) Con cuidado vuelva a colgar el televisor con los soportes en la Placa de TV [05].

9-7 (Fig. 7) Use los pernos [G2] para volver a instalar las cerraduras de seguridad [F2] en los lados del soporte para TV [07].

**NOTA:** Vuelva a conectar los cables y el cable de alimentación del Televisor.

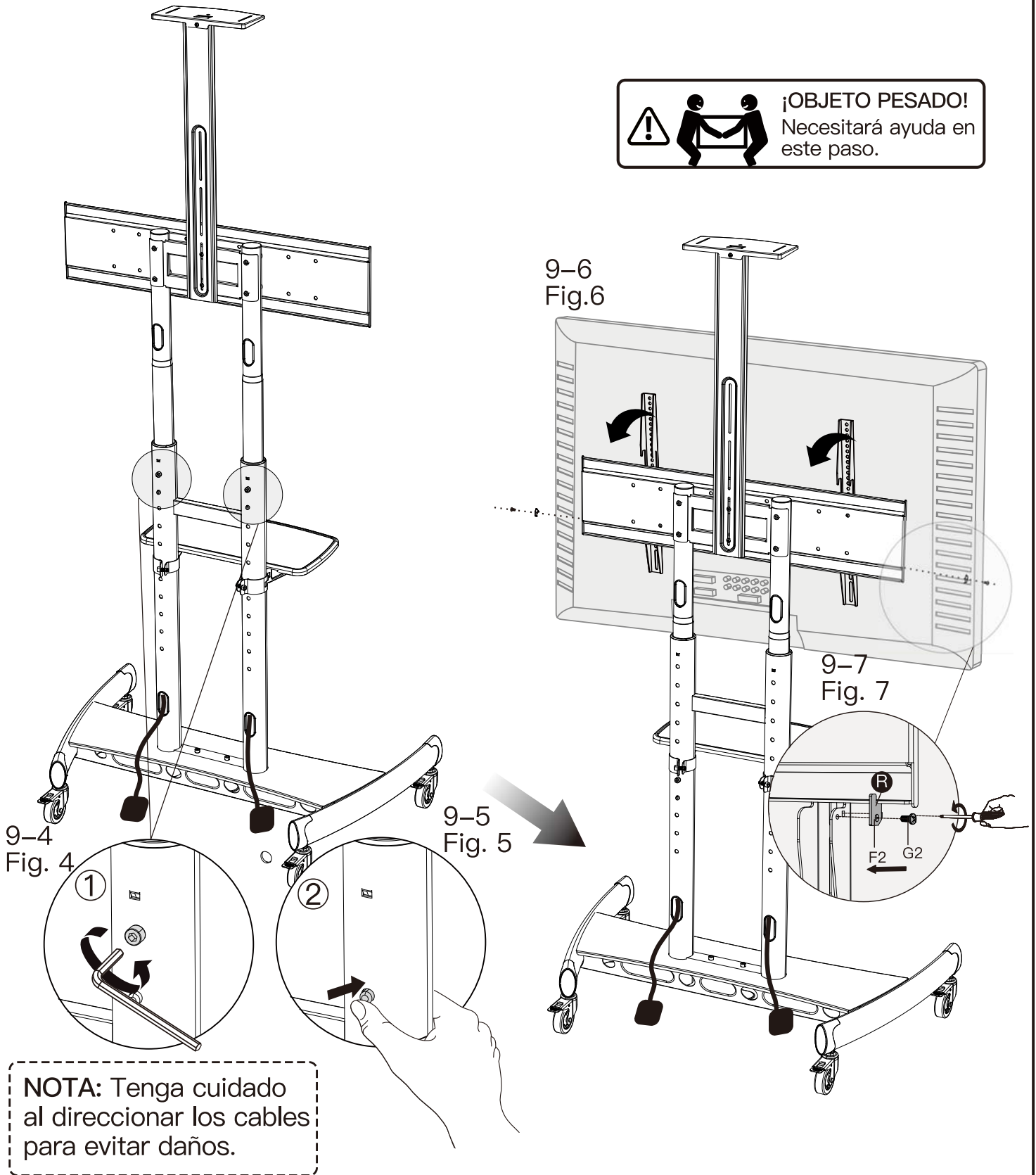









At ErgoAV, we strive to provide the highest value products.  
We want to support your purchase.  
If you have questions, concerns,  
or feedback please let us know!

ErgoAV Customer Care  
Phone (877) 419-7832  
[support@ergoav.com](mailto:support@ergoav.com)

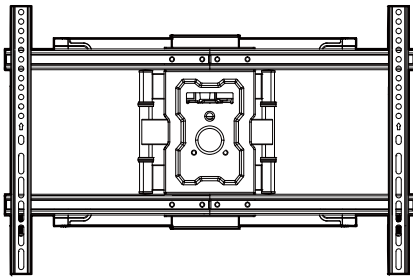

TV Mounts

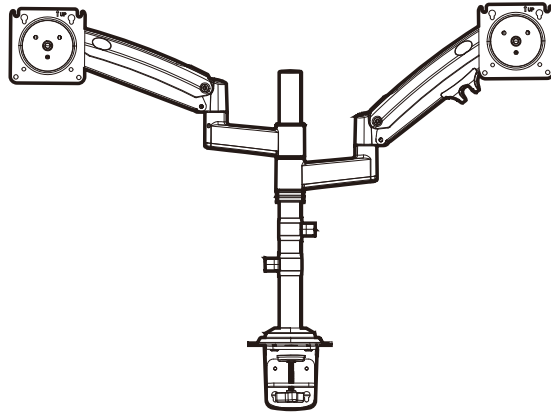

Computer Monitor Mounts

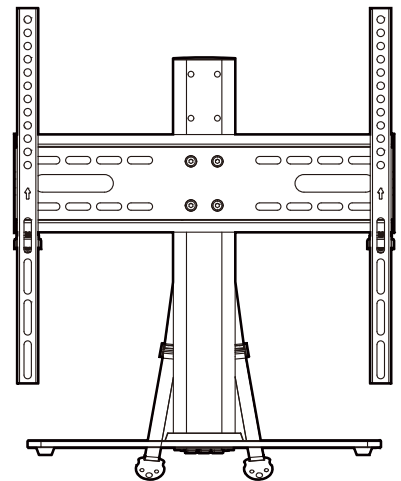

Tabletop TV Stands

9501 Louisiana Ave N, #200, Brooklyn Park, MN 55445  
[www.ergoav.com](http://www.ergoav.com)