



# Motion TV Mount with Locking Arm Instruction Manual

(A)

English pages: 02–15

French pages: 16–29

Spanish pages: 30–43

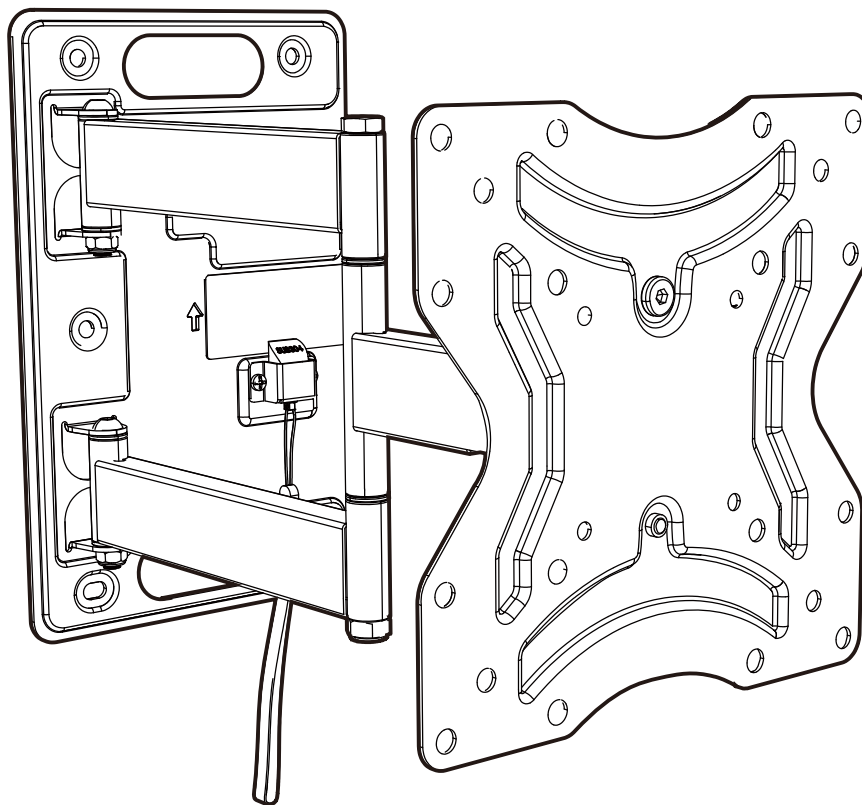

**Model: ERMSS1-01B**

Thank You for Choosing this ErgoAV Product!

At ErgoAV, we want to add value to your AV experience by providing the highest quality products and services in the industry. If you have any concerns or comments, please contact us.

ErgoAV Customer Care

phone (877) 419-7832

email: [support@ergoav.com](mailto:support@ergoav.com)

website: [www.ergoav.com](http://www.ergoav.com)

address: 9501 Louisiana Ave N, #200, Brooklyn Park, MN 55445

## IMPORTANT SAFETY INFORMATION

**⚠ DANGER!** Please carefully read all instructions before attempting installation. If you DO NOT understand the instructions or have any concerns or questions, please contact our Technical Support at (877) 419-7832 or Customer Service at support@ergoav.com.

**⚠ CAUTION:** Use with products heavier than the maximum weights indicated may result in instability causing possible injury.

- DO NOT use this product for any purpose that is NOT explicitly specified in this manual. DO NOT exceed weight capacity. We are NOT liable for damage or injury caused by improper mounting, incorrect assembly or inappropriate use.
- This product is designed for use in wood stud, solid concrete, and concrete block walls – DO NOT install into drywall alone. Please note: When installing into a recreational vehicle, please consult our Customer Service at support@ergoav.com to determine the correct screw depth to use for your installation.
- The wall must be capable of supporting four times the weight of the TV and mount combined.
- Use this mounting system only for its intended use as described in these instructions. DO NOT use attachments NOT recommended by the manufacturer.
- DO NOT use outdoors.
- Route cords and cables properly to avoid mechanical damage.
- SAVE THESE INSTRUCTIONS.

## Weight Restrictions



If your TV weighs more, DO NOT use this product.

### **⚠ WARNING**

DO NOT exceed the maximum weight indicated. This mounting system is intended for use only within the maximum weights indicated. Use with products heavier than the maximum weights indicated may result in failure of the mount and its accessories, causing damage and or injury.

## Check the VESA Pattern of Your TV before the Installation

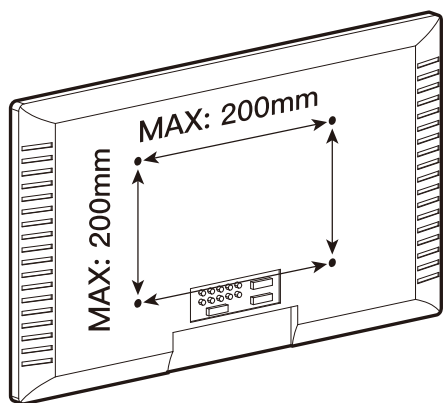

For VESA Patterns:

75mm x 75mm ≈ 3" x 3"

100mm x 100mm ≈ 3.9" x 3.9"

200mm x 100mm ≈ 7.9" x 3.9"

200mm x 200mm ≈ 7.9" x 7.9"

Minimum: 75mm x 75mm / 3" x 3" (W x H)

Maximum: 200mm x 200mm / 7 7/8" x 7 7/8" (W x H)

If your TV's VESA Pattern is smaller than 75mm x 75mm or greater than 200mm x 200mm, this mount is NOT COMPATIBLE with your TV. Please contact our Technical Support at (877) 419-7832 or support@ergoav.com to find a compatible mount.

## Tools Needed (NOT Included)



Tape Measure



Phillips  
Screwdriver



Pencil

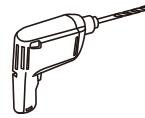

Electric Drill

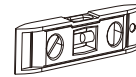

Level



7/16" (11mm)  
Socket Wrench

(Needed for wood stud installs)



Stud Finder

OR



Awl



5/32" (4mm)  
Wood Drill Bit

(Tools Needed for Solid Concrete,  
Concrete Block and Brick Wall Installation)



5/16" (8mm)  
Concrete Drill Bit



Hammer

## Verify Your Wall Construction

**CAUTION**

DO NOT  
install into  
drywall alone.

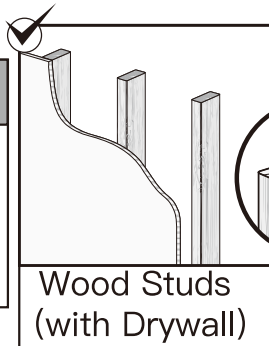

Wood Studs  
(with Drywall)

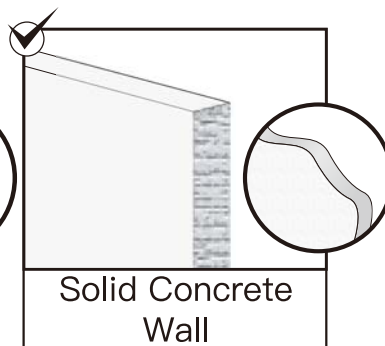

Solid Concrete  
Wall

If you are not sure of  
the wall construction,  
please contact our  
Technical Support  
at (877) 419-7832 or  
Customer Service at  
support@ergoav.com.

## Supplied Parts and Hardware

**WARNING:** This product contains small items that could be a choking hazard if swallowed.

Before starting assembly, verify all parts are included and undamaged. Do not use damaged or defective parts. If you need replacement parts, please contact our Technical Support at (877) 419-7832 or Customer Service at support@ergoav.com.

- **PLEASE NOTE:** NOT all hardware included in this package will be used.

## Supplied Parts and Hardware for Step 1

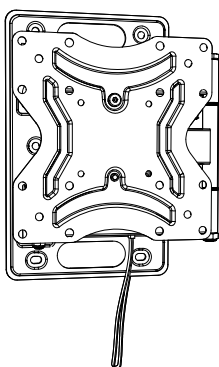

TV Mount **01** x1

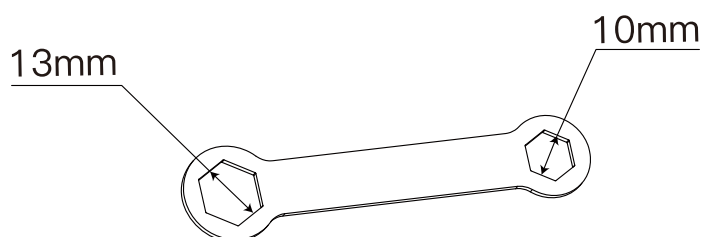

Wrench **02** x1

## Step 1 Unlock the Arm & Detach the Faceplate

1-1 Pull the strap down and stretch the arm away from the wall plate.

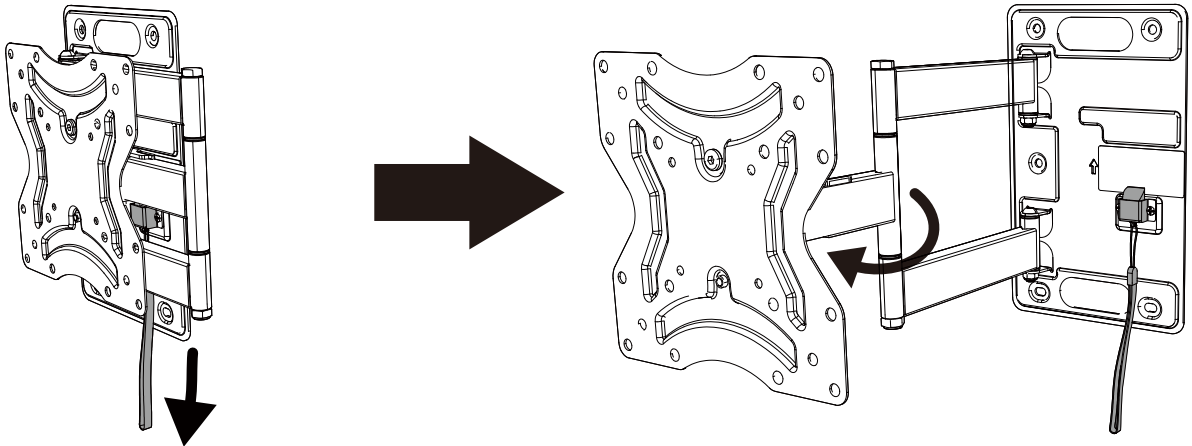

1-2 Slightly unscrew but NOT remove the Nut [S2] with the Wrench [02].

1-3 Remove the Bolt [S1] with the Wrench [02] or a self-supplied screwdriver and keep it for use in step 4-2 on page 13.

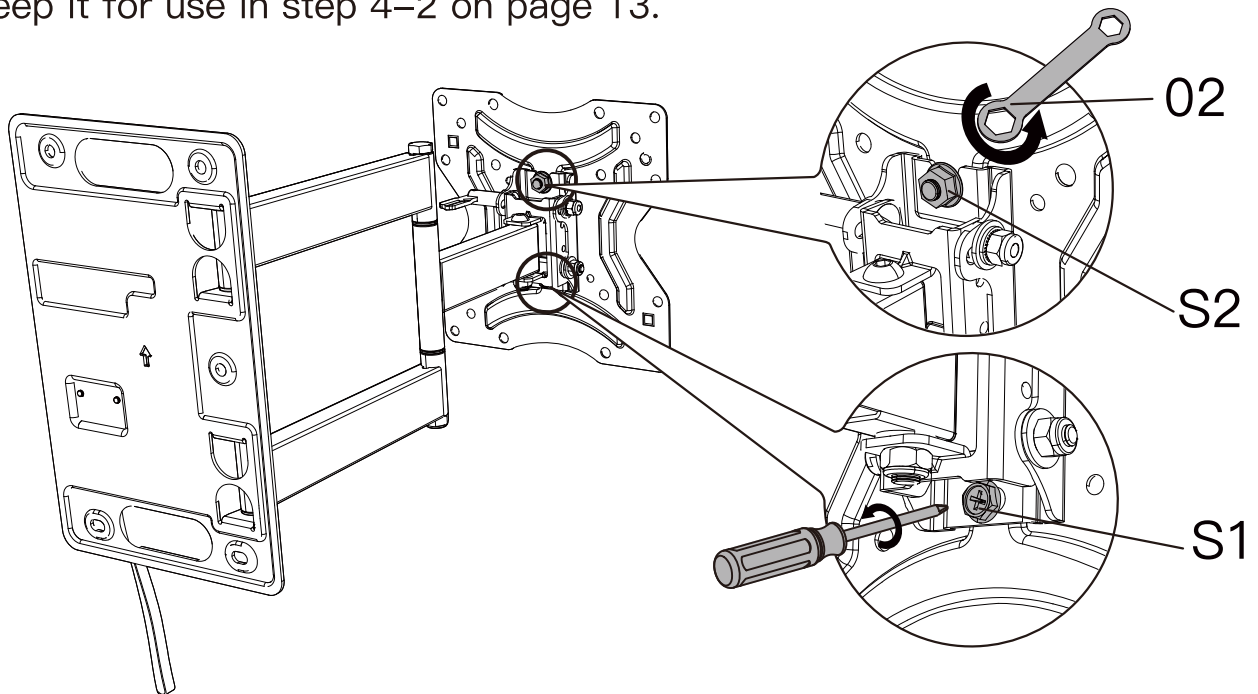

1-4 Separate the Faceplate [01B] from the Arm Assembly/Wall Plate [01A].

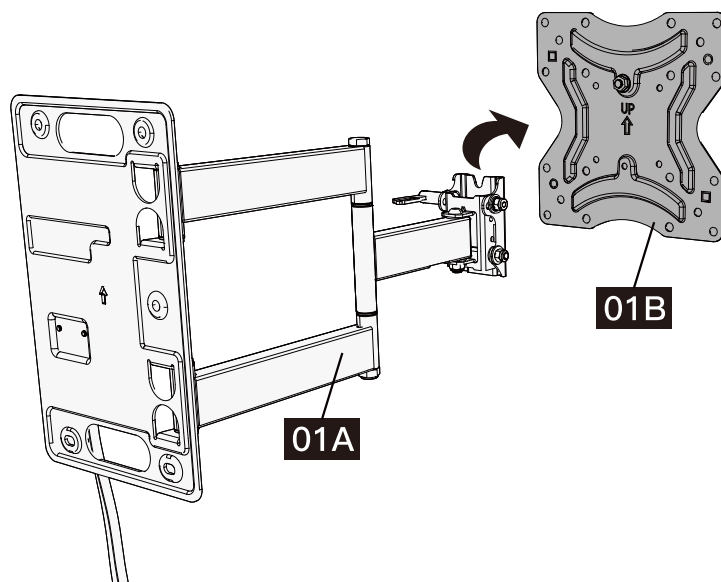



# Supplied Parts and Hardware for Step 2

## 04 Washers

## 05 Spacers [If needed]

**NOTE:** The washers and spacers shown are actual size.

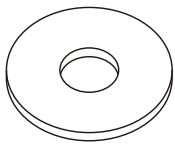

[B1] x4  
M4/M5

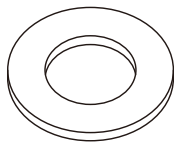

[B2] x4  
M6/M8



[G1] x4  
L2.5mm

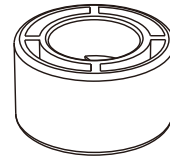

[G2] x8  
L10mm

## 06 TV Bolts [Only one size of the bolt fits your TV]

**NOTE:** The bolts shown are actual size.

**M4**



M4 x 12mm  
[C1] x4

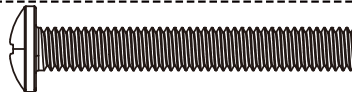

M4 x 30mm  
[C2] x4

**M5**

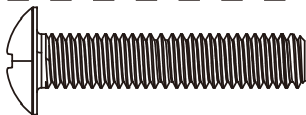

M5 x 25mm  
[D] x4

**M6**

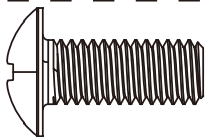

M6 x 15mm  
[E1] x4

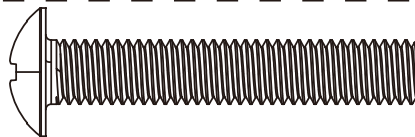

M6 x 35mm  
[E2] x4

**M8**

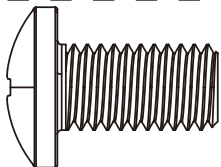

M8 x 15mm  
[F1] x4

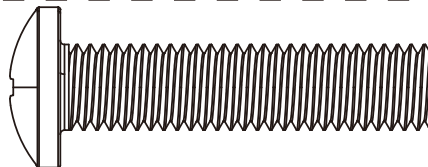

M8 x 35mm  
[F2] x4

# Step 2 Secure the TV Faceplate to the TV

## Select TV Bolts

Only one bolt size fits your TV.

M4

M5

M6

M8

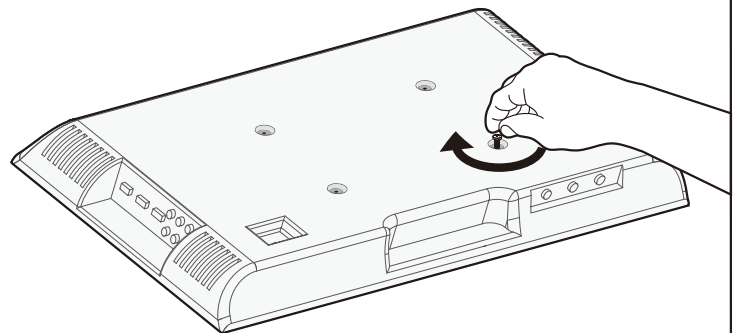
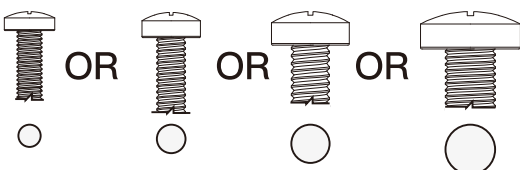

**NOTE:** Please DO NOT over tighten the TV bolts to avoid damaging your TV.  
**Bolt length:** Verify adequate thread engagement with bolts or bolts/spacers combination. We recommend thread engagement by at least 5 turns.

-Too short will NOT hold the TV.

-Too long will damage the TV.

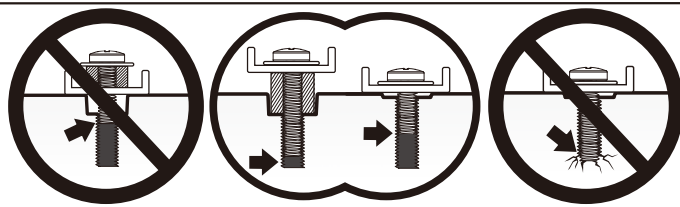

Too Short

Correct

Too Long

**Please Note:** If spacers are required for your installation, a combination of different spacers can be stacked to obtain a proper length. See examples in the image below. If you have any difficulty understanding how to install the TV bolts or spacers, please contact our Tech Support at (877) 419-7832 or Customer Service at support@ergoav.com.

## Parts Needed if You Have a TV as Shown Below

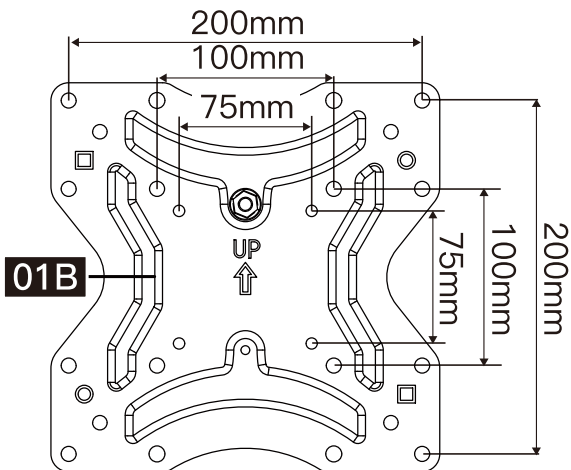
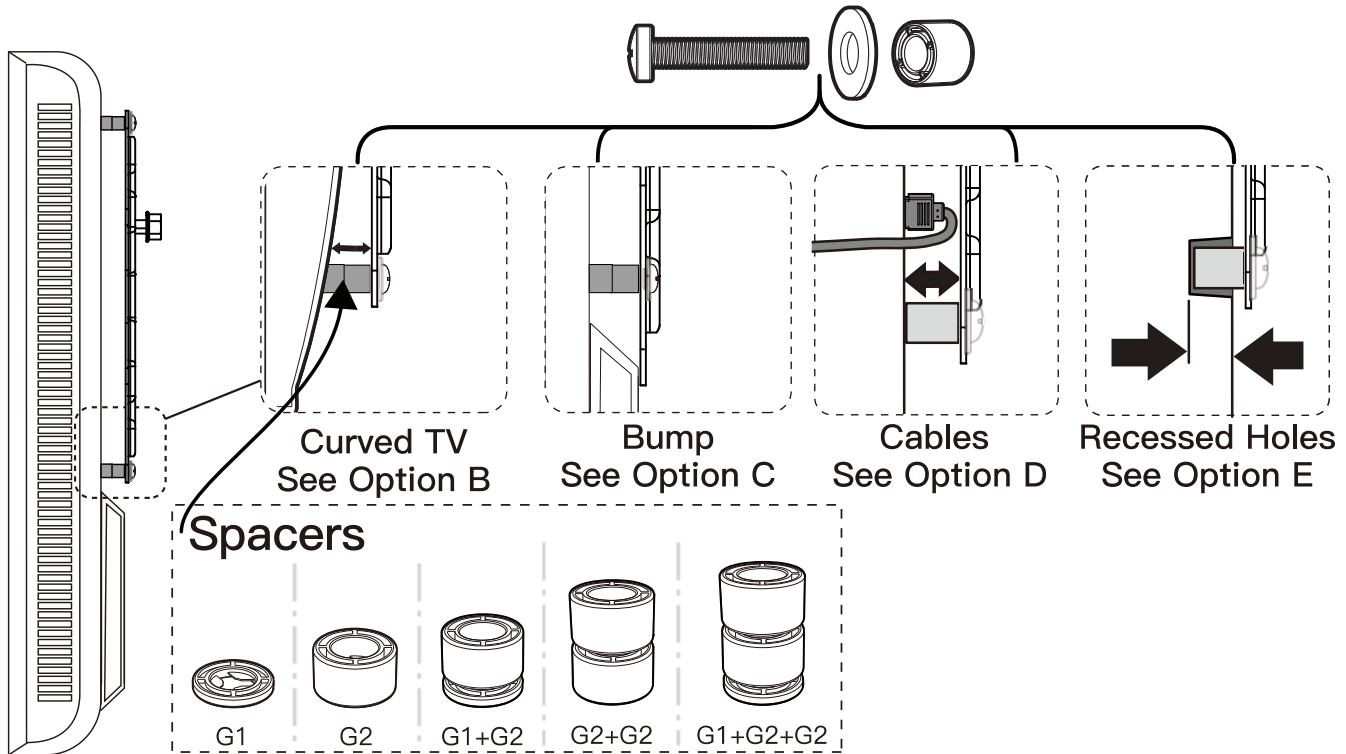

For VESA Patterns:

75mm x 75mm  $\approx$  3" x 3"

100mm x 100mm  $\approx$  3.9" x 3.9"

200mm x 100mm  $\approx$  7.9" x 3.9"

200mm x 200mm  $\approx$  7.9" x 7.9"

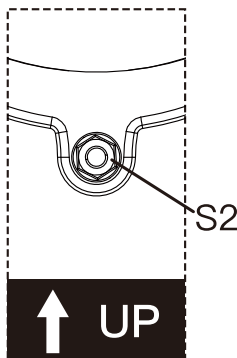
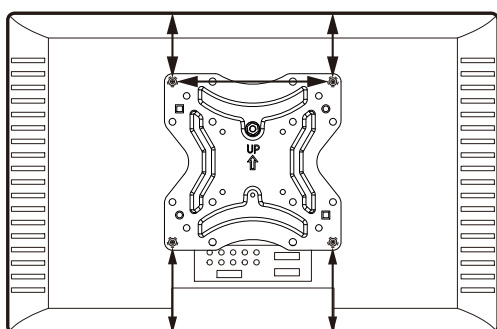

**⚠ CAUTION:** When attaching the Faceplate [01B] to the back of the TV, ensure the Pre-Assembled Nut [S2] is toward to the top of the TV and is equally centered on the back of the TV.

**⚠ PLEASE NOTE:** The bolt hole locations on your TV may vary in accordance with the manufacturer's design of the TV. We are only illustrating possible locations of the bolt holes.

### Option A (For Flat Back TV)

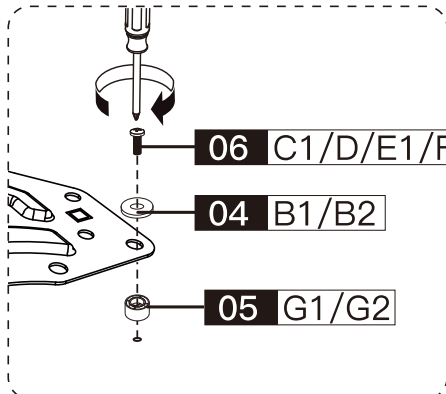

Refer back to Spacer Instructions on Page 6, If NEEDED

Phillips Screwdriver (NOT Included)



### Option B (For Curved Back TV)

The Spacers must be tall enough so that the curve on the back of the TV will NOT interfere with the mounting plate.

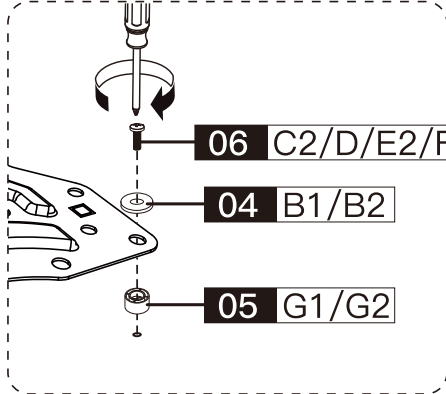

Refer back to Spacer Instructions on Page 6, If NEEDED

Phillips Screwdriver (NOT Included)

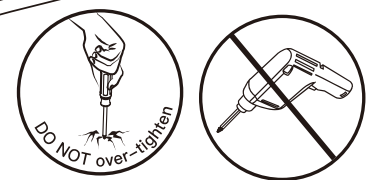

### Option C (For TV with A "Bump")

The spacers must be tall enough so there is no gap between the faceplate and bump on the back of the TV.

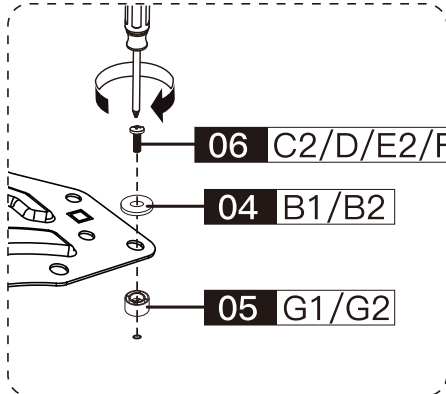

Refer back to Spacer Instructions on Page 6, If NEEDED

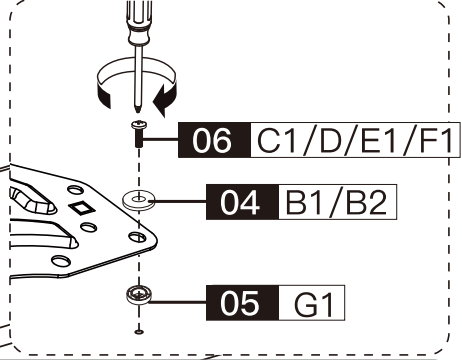

Refer back to Spacer Instructions on Page 6, If NEEDED

Phillips Screwdriver (NOT Included)

## Option D (For TV with Cable Interference)

For cable interference, use the Spacers [G1] and [G2] to create extra space between the TV and TV faceplate.



Phillips Screwdriver  
(NOT Included)

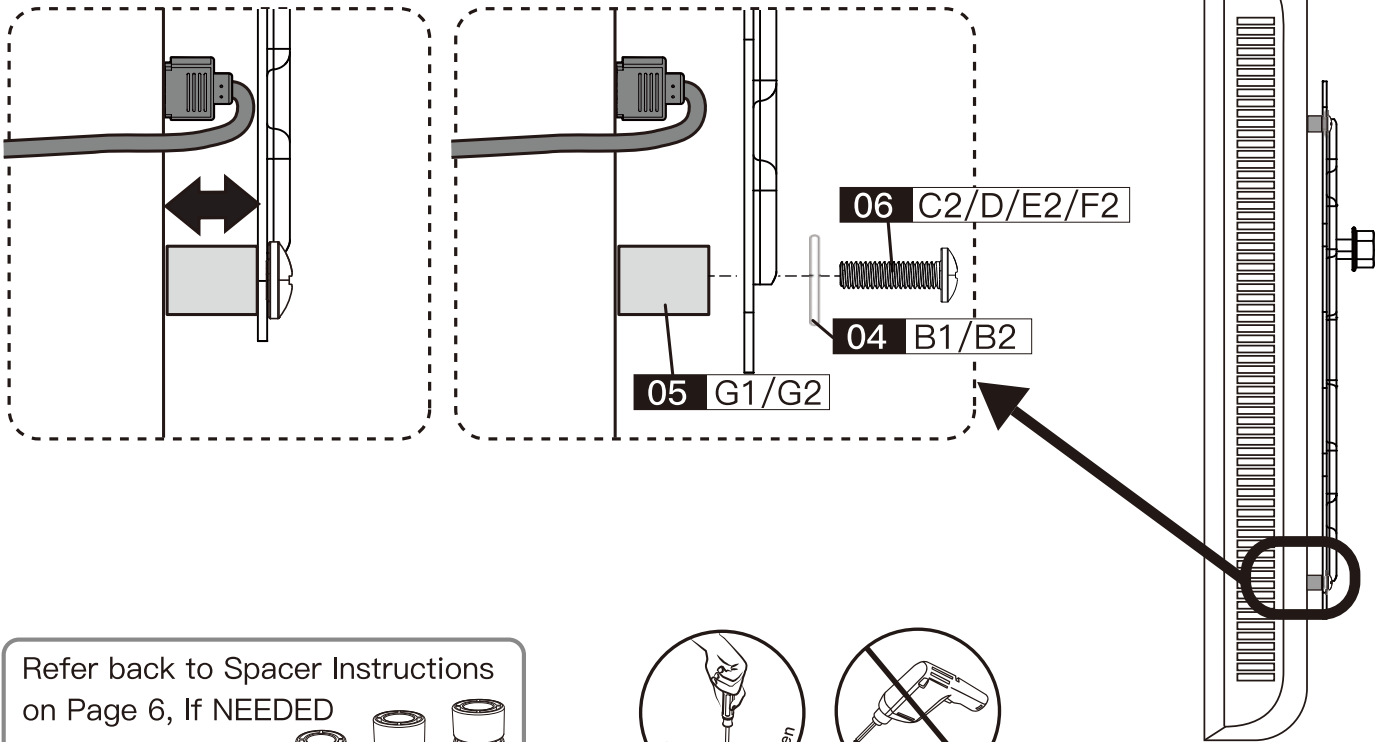

Refer back to Spacer Instructions  
on Page 6, If NEEDED



## Option E (For Recessed Holes)

The Spacer [G1] and [G2] needs to fill in the recessed holes on the back of the TV so that the TV faceplate are as close to the TV as possible.

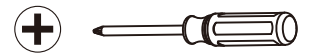

Phillips Screwdriver  
(NOT Included)

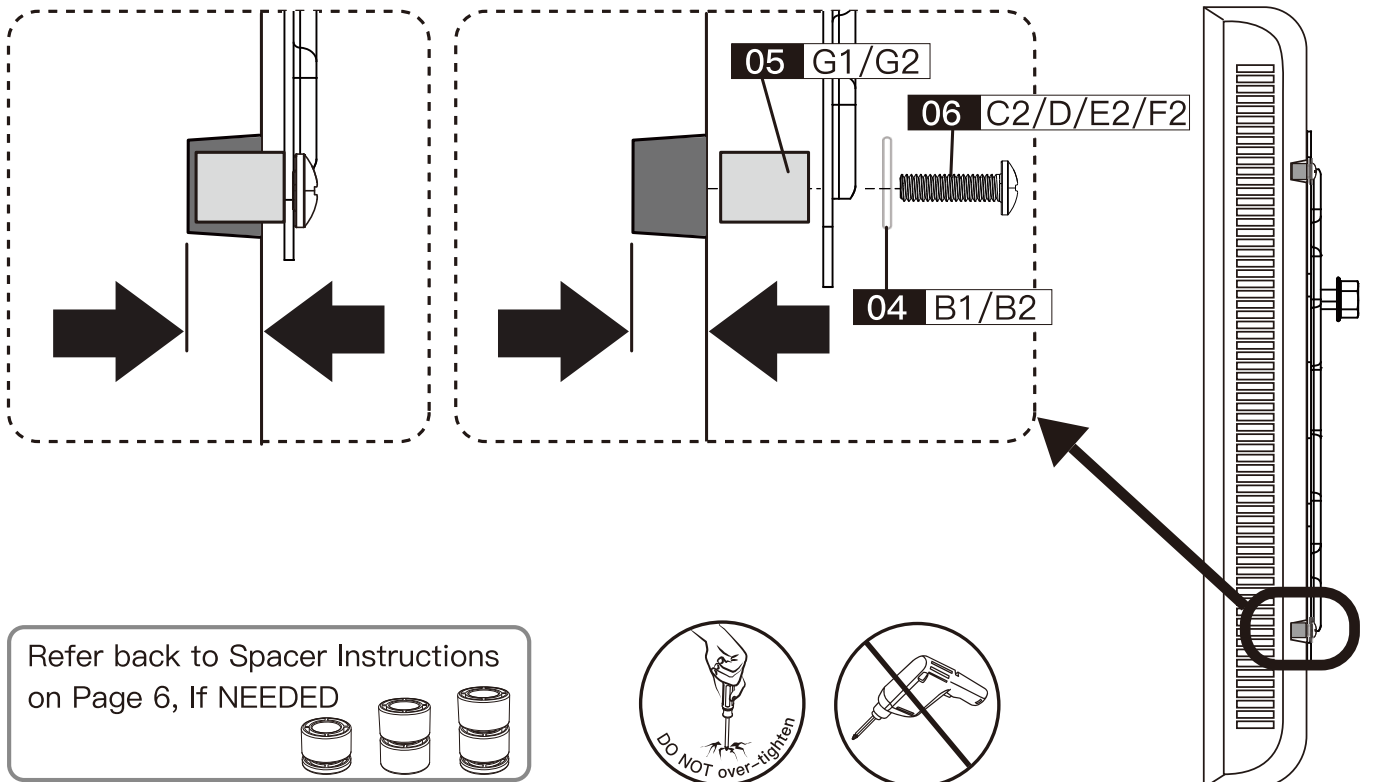

Refer back to Spacer Instructions  
on Page 6, If NEEDED



# Supplied Part and Hardware for Step 3

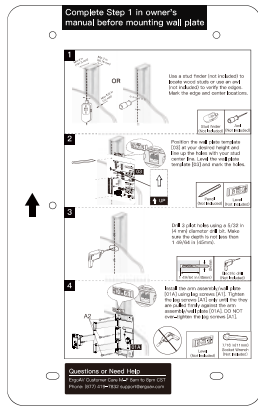

**03** x1  
Wall Plate Template

**A1** x5 Lag Screw  
1/4" x 1 3/4"



**A2** x5 Wall Anchor  
8 x 40mm

**! CAUTION!**  
This anchor is for concrete walls ONLY. DO NOT use them in drywall or wood studs.

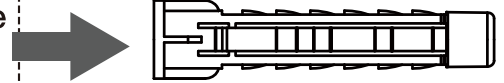

## Step 3 Attach the Arm Assembly/Wall Plate [01] to the Wall

For wood stud installation, follow STEP 3A.

For concrete installation, follow STEP 3B.

### Step 3A Wood Stud Option

**! WARNING:**

DO NOT use a drill for tightening the lag screws, only use a socket wrench.

**! CAUTION:**

If installation is in a RV, before drilling, ensure your wall thickness is greater than 2" thick.

- DO NOT USE ANCHOR [A2] FOR THIS STEP.
- Ensure the wall plate is securely fastened to the wall before continuing to the next step.
- Nominal wood stud size: common 2" x 4" (51mm x 102mm)
- Stud center must be verified.



### 3A-1

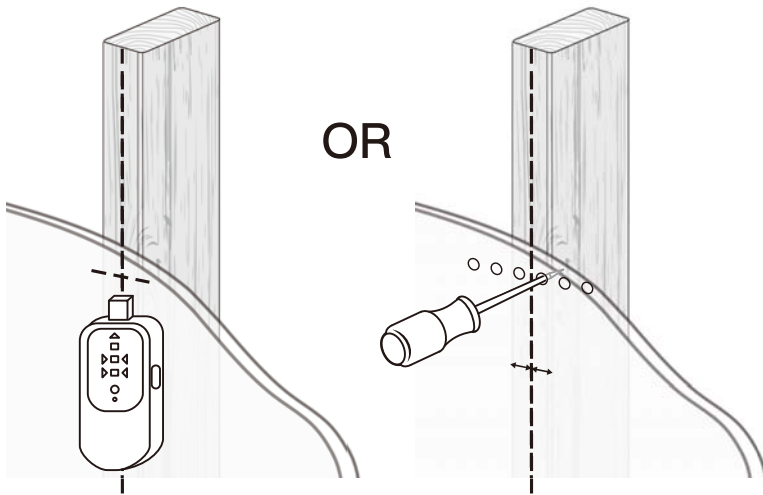

Use a stud finder (Not included) to locate wood studs or use an awl (Not included) to verify the edges. Mark the edge and center locations.

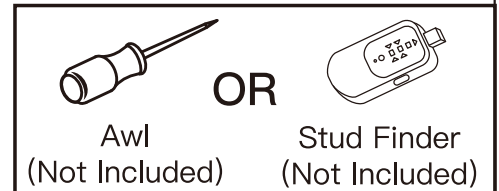

### 3A-2

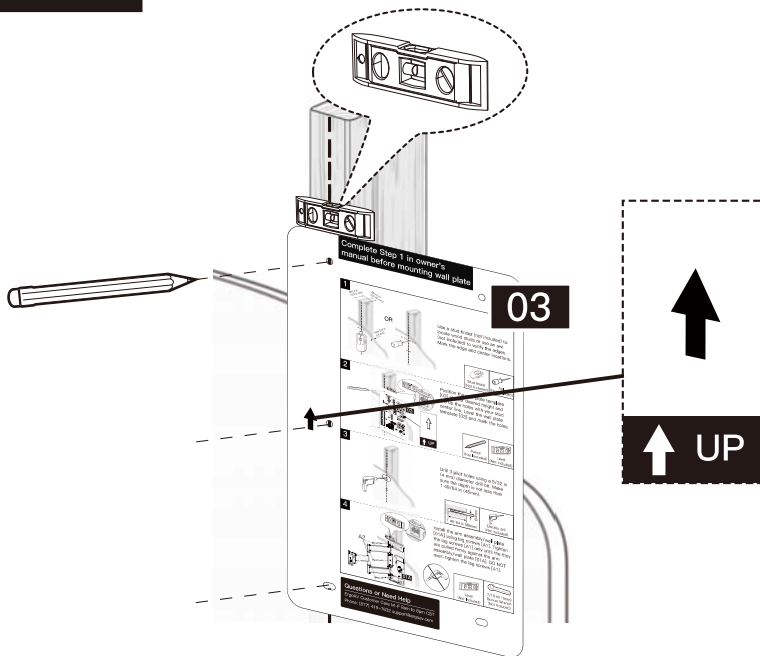

Position the Wall Plate Template [03] at your desired height and line up the holes with your stud center line. Level the Wall Plate Template [03] and mark the holes.

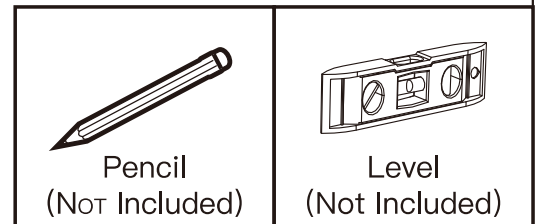

### 3A-3

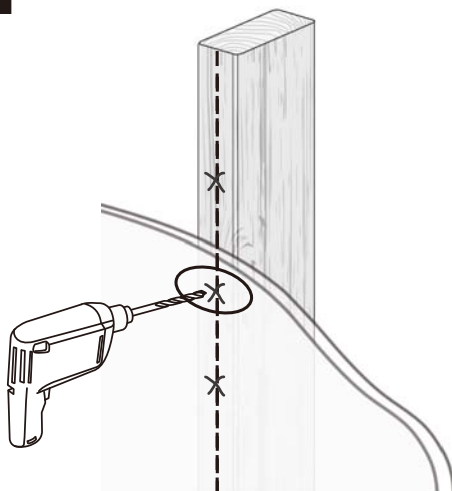

Drill 3 pilot holes using a 5/32" (4mm) diameter drill bit. Make sure the depth of the holes is NOT less than 1 3/4" (45mm) deep.

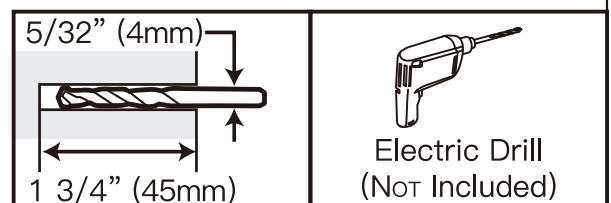



### 3A-4

**NOTE:** DO NOT use a drill to tighten the lag screws. Only use a socket wrench.



**HEAVY!** You may need assistance with this step.

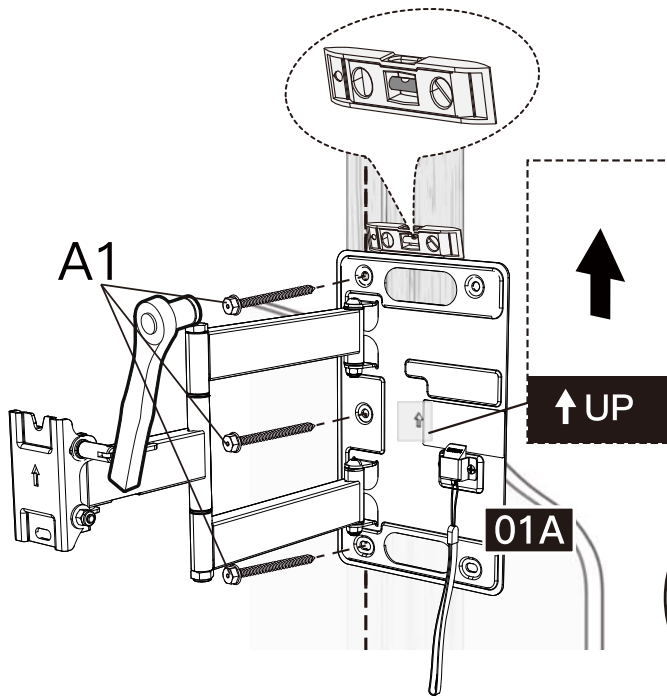

Install the Arm Assembly/Wall Plate [01A] using 3 Lag Screws [A1]. Tighten the Lag Screws [A1] only until they are pulled firmly against the Arm Assembly / Wall Plate [01A]. DO NOT over-tighten the Lag Screws [A1].

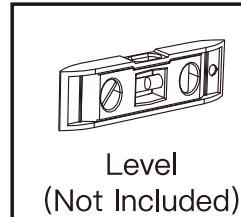
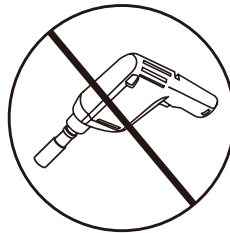

## Step 3B Solid Concrete Wall Option

### **WARNING:**

DO NOT use a drill for tightening the lag screws! Only use a socket wrench.

- Avoid potential personal injury or property damage! DO NOT over-tighten the lag Screws [A1]. Tighten the lag Screws [A1] only until they are pulled firmly against the wall plate.
- Ensure the wall plate is securely fastened to the wall before continuing to the next step.
- Mount the wall plate directly onto the concrete surface without any covering.
- The thickness of the concrete wall must exceed 5.5" (140 mm).



**A2**  
Wall  
Anchor

### 3B-1

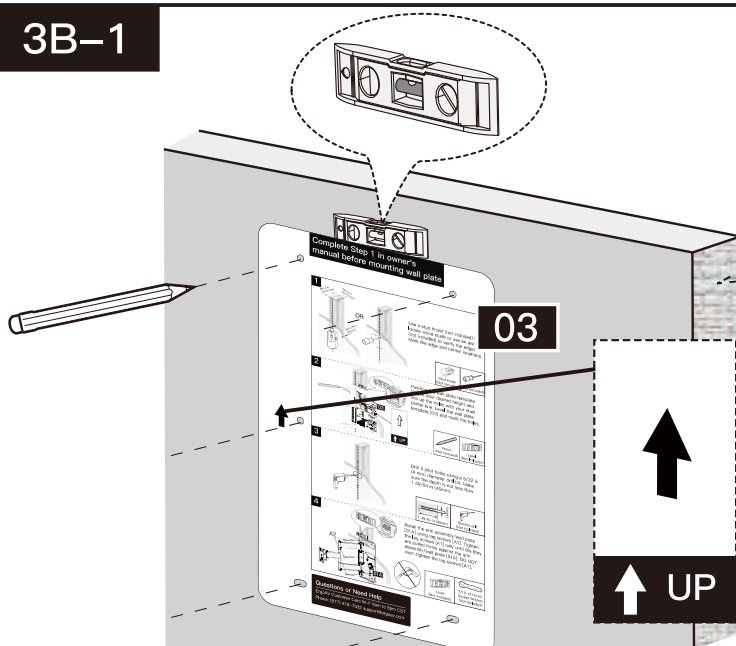

Wall Thickness  
≥5.5" (140mm)

Position the Wall Plate Template [03] at your desired height, level the Wall Plate Template [03] and mark the pilot hole locations.

### 3B-2

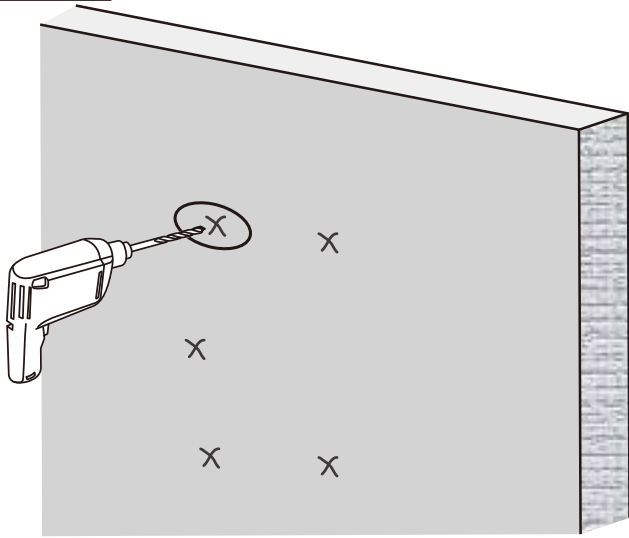

Drill 5 pilot holes using a 5/16" (8mm) diameter drill bit. Make sure the depth of the holes is not less than 2" (50mm) deep.

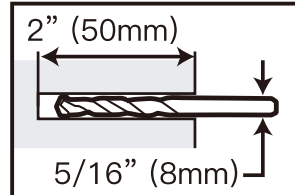

### 3B-3

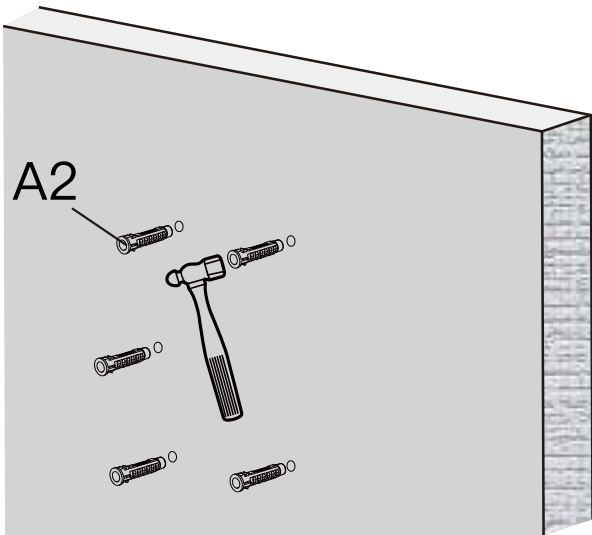

Use the hammer to knock the Anchors [A2] into the wall. Be sure the Anchors [A2] are seated flush with the concrete surface.

### 3B-4

**! WARNING:** DO NOT use a drill to tighten the lag screws. Only use a socket wrench.

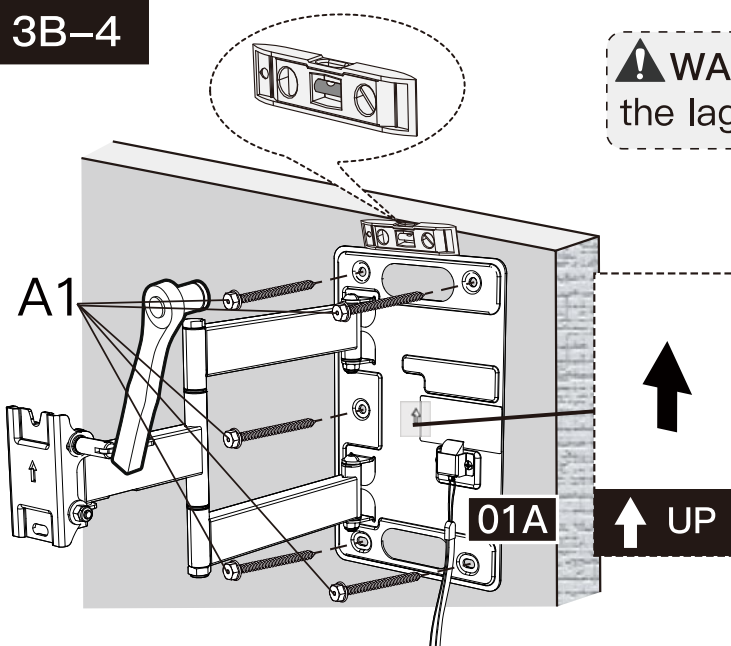

Install the Arm Assembly/Wall Plate [01A] using 5 Lag Screws [A1]. Tighten the Lag Screws [A1] only until they are pulled firmly against the Arm Assembly / Wall Plate [01A]. DO NOT over-tighten the Lag Screws [A1].

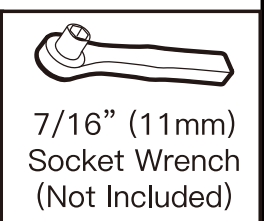
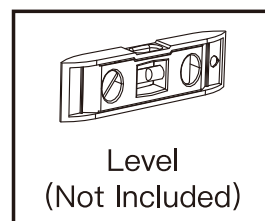
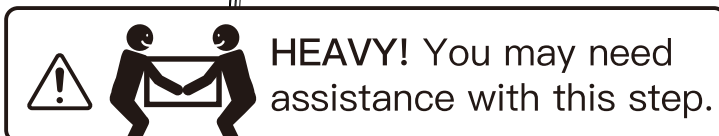

## Step 4 Hang the TV onto the Arm Assembly/Wall Plate [01A]



**HEAVY!** You may need assistance with this step.

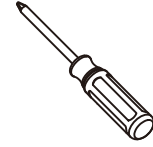

Phillips  
Screwdriver  
(Not Included)

**4-1** Hang the TV on to the Arm Assembly / Wall Plate [01A], making sure the Pre-Assembled Nut [S2] hangs inside the hook on the Arm Assembly / Wall Plate [01A].

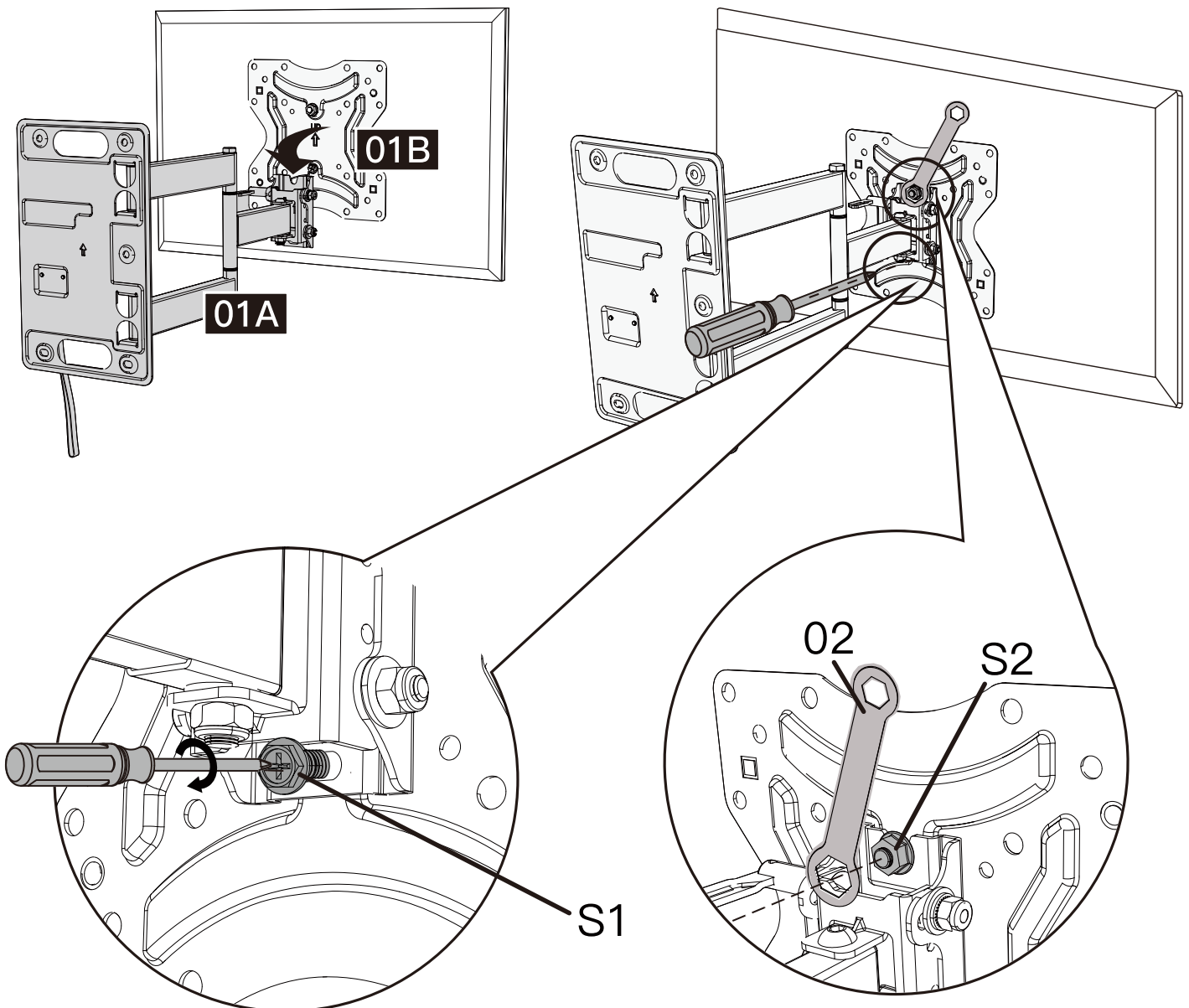

**4-2** Install and tighten the Bolt [S1] which was removed in step 1-3 to secure the TV to the Arm Assembly/Wall Plate [01A].

**4-3** Tighten the Nut [S2].

## Step 5 Adjustments

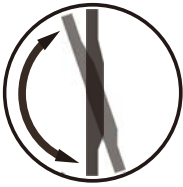

Tilt Adjustment

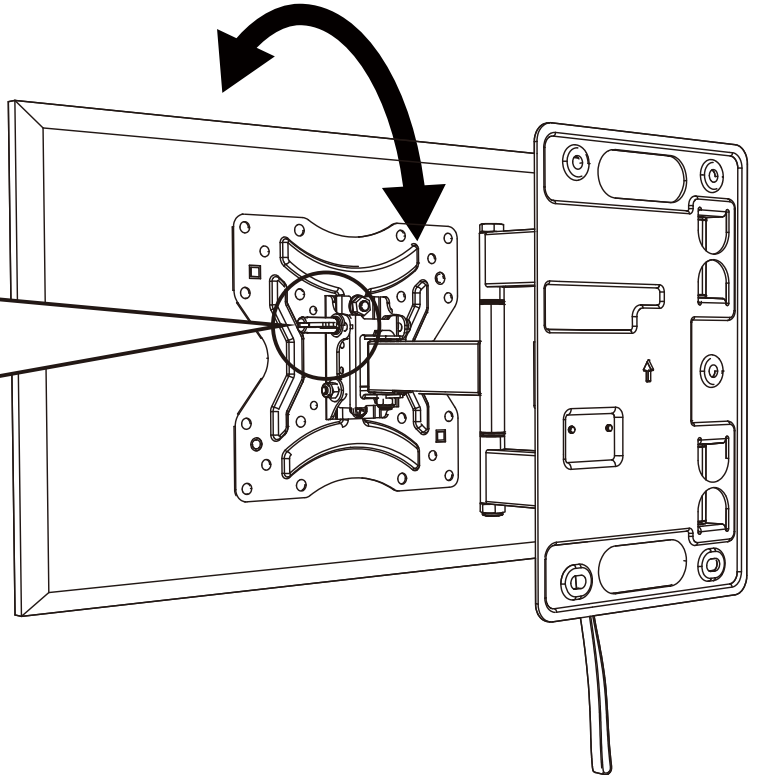
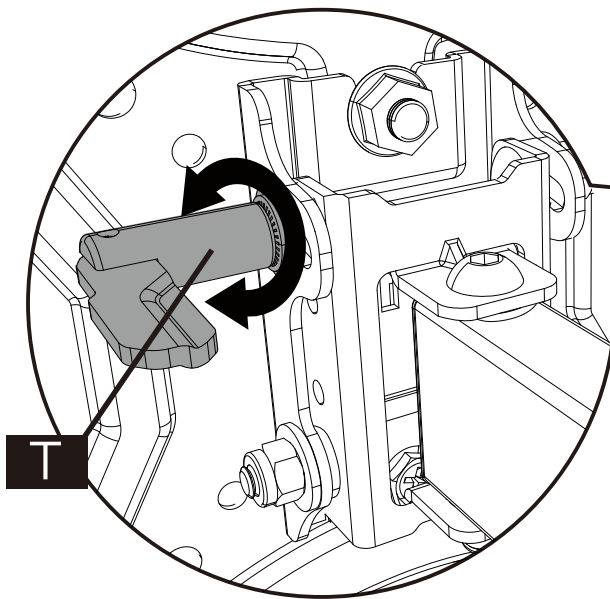

1. Gently loosen the lever [T] by hand.
2. Adjust the TV to your desired angle.
3. Tighten the lever [T] to secure the TV.



If needed, the TV can be levelled.



Phillips  
Screwdriver  
(NOT Included)

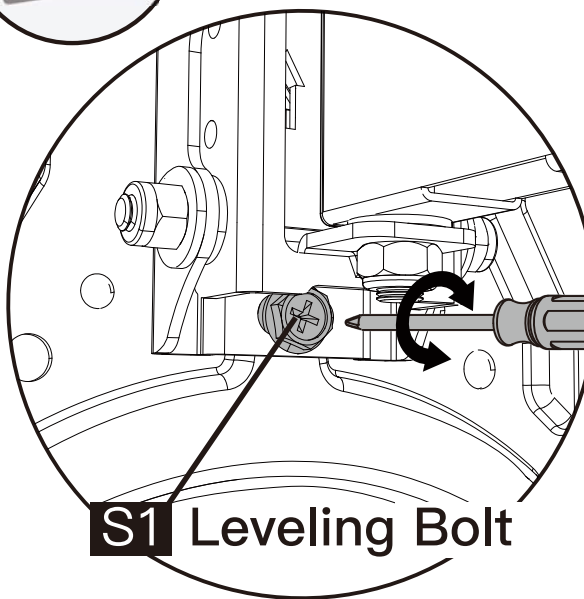

**S1** Leveling Bolt

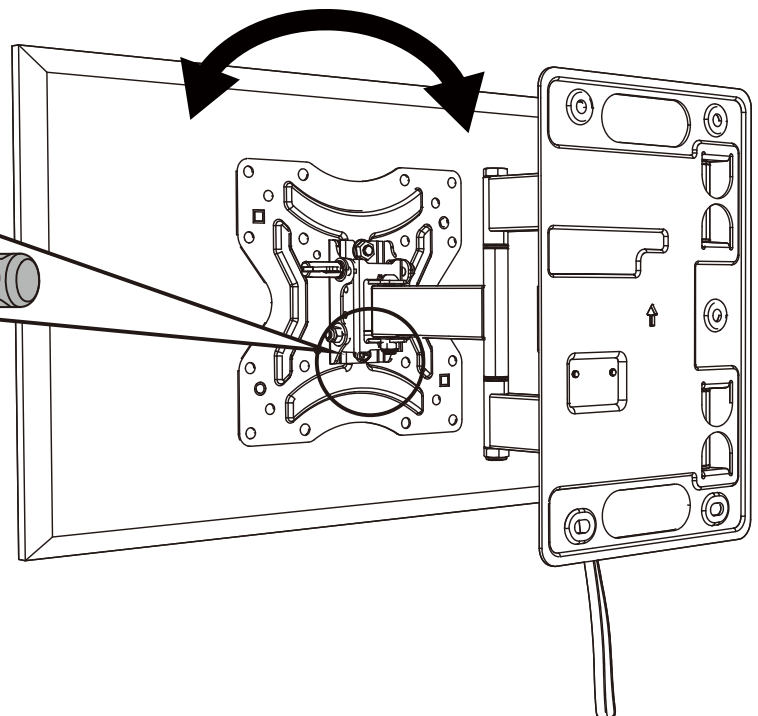

1. Loosen the Bolt [S1] 1/4 of a turn.
2. Adjust the TV to be level.
3. Retighten the Bolt [S1] firmly.

## Step 6 Storing your TV

**6-1** To store your TV against the wall, gently push the TV against the wall while holding the strap down. Once the TV is against the wall, release strap and check to make sure the TV is being held in place by the latch.

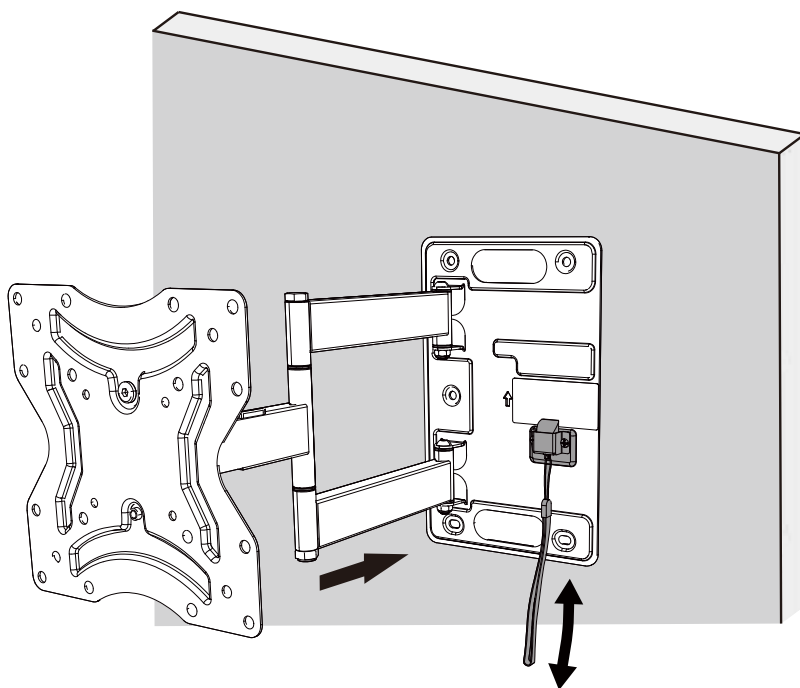

**6-2** To release your TV from the stored position, gently push the TV against the wall and pull down on the strap. Once the TV is away from the wall, release strap.

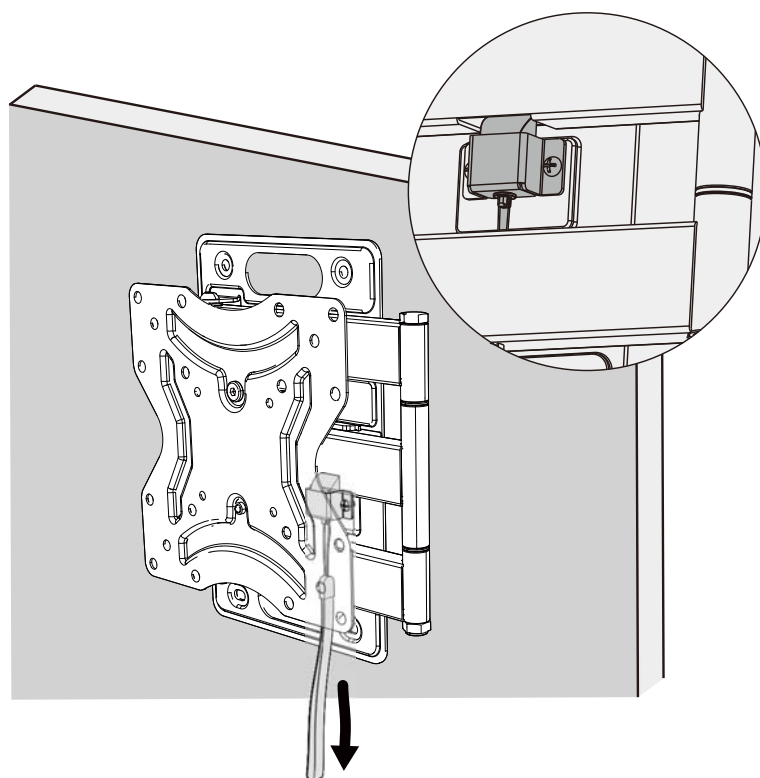



## Consignes de sécurité importantes

**⚠ DANGER !** Veuillez lire attentivement toutes les instructions avant de tenter l'installation. Si les instructions ne vous semblent pas claires ou si vous avez des questions, veuillez contacter notre service d'assistance technique au (877) 419-7832 ou notre service clientèle à l'adresse [support@ergoav.com](mailto:support@ergoav.com).

**⚠ ATTENTION :** L'utilisation avec des produits plus lourds que les poids maximums indiqués peut entraîner une instabilité et des blessures possibles.

- N'utilisez pas ce produit à des fins qui ne sont pas explicitement spécifiées dans ce manuel. Ne dépassez pas la capacité de charge. Nous ne sommes pas responsables des dommages ou blessures causés par un montage incorrect, un assemblage incorrect ou une utilisation inappropriée.

- Ce produit est conçu pour être utilisé dans des murs à ossature de bois, en béton solide et en blocs de béton – NE PAS installer dans des cloisons sèches seules. Veuillez noter : lors de l'installation dans un véhicule récréatif, veuillez consulter notre service client à [support@ergoav.com](mailto:support@ergoav.com) pour déterminer la profondeur de vis correcte à utiliser pour votre installation.

- Le mur doit être capable de supporter quatre fois le poids du téléviseur et du support combinés.

- Utilisez ce système de montage uniquement pour l'usage auquel il est destiné, tel que décrit dans ces instructions. N'utilisez pas d'accessoires non recommandés par le fabricant.

- Ne pas utiliser à l'extérieur.

- Acheminez correctement les cordons et les câbles pour éviter tout dommage mécanique.

- SAUVEGARDER CES INSTRUCTIONS.

## Restrictions de poids



Si votre téléviseur pèse plus lourd, n'utilisez pas ce produit.

### ⚠ AVERTISSEMENT

NE PAS dépasser le poids maximum indiqué. Ce support TV est destinée à être utilisé uniquement dans la limite des poids maximums indiqués. L'utilisation de produits plus lourds que les poids maximums indiqués peuvent entraîner une défaillance du support TV et de ses accessoires, et provoquer des dommages et/ou des blessures.

## Vérifiez le modèle VESA du TV avant l'installation

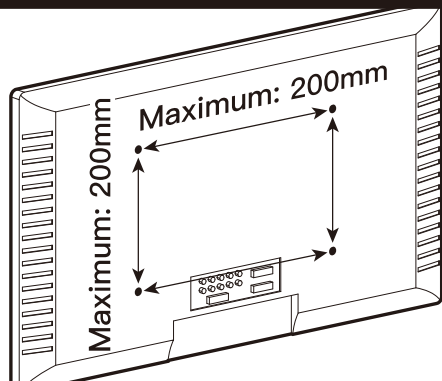

Pour le modèle VESA:

75mm x 75mm ≈ 3 x 3 pouce

100mm x 100mm ≈ 3.9 x 3.9 pouce

200mm x 100mm ≈ 7.9 x 3.9 pouce

200mm x 200mm ≈ 7.9 x 7.9 pouce

Minimum : 75mm x 75mm / 3 x 3 pouce (W x H)

Maximum : 200mm x 200mm / 7 7/8 x 7 7/8 pouce (W x H)

Si le motif VESA de votre Téléviseur est inférieur à 75 mm x 75 mm ou supérieur à 200 mm x 200 mm, ce support n'est PAS COMPATIBLE avec votre Téléviseur. Veuillez contacter notre support technique au (877) 419-7832 ou [support@ergoav.com](mailto:support@ergoav.com) pour trouver un support compatible.



## Outils nécessaires (non inclus)

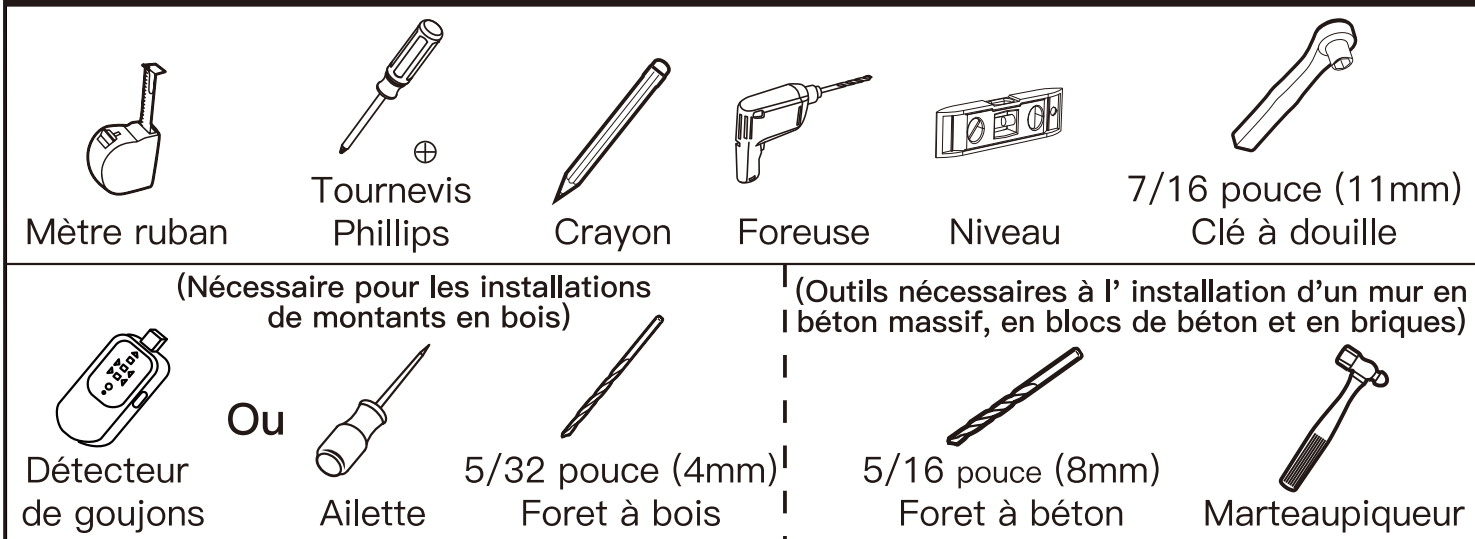

## Vérifiez la construction de vos murs

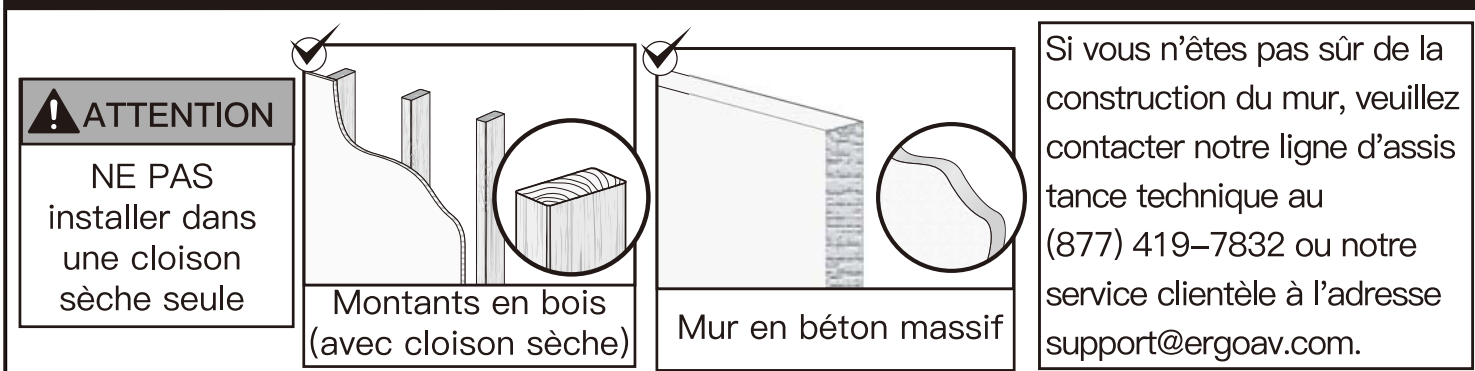

## Pièces et matériel fournis

**! AVERTISSEMENT** : Ce produit contient des petits objets susceptibles de présenter un risque d'étouffement en cas d'ingestion.

Avant de commencer l'assemblage, vérifiez que toutes les pièces sont incluses et en bon état. N'utilisez pas de pièces endommagées ou défectueuses. Si vous avez besoin de pièces de rechange, veuillez contacter notre ligne d'assistance technique au (877) 419-7832 ou notre service clientèle à l'adresse [support@ergoav.com](mailto:support@ergoav.com)

- Veuillez noter : le matériel inclus dans cet ensemble ne sera pas utilisé en totalité.

## Pièces et matériel fournis pour l'étape 1

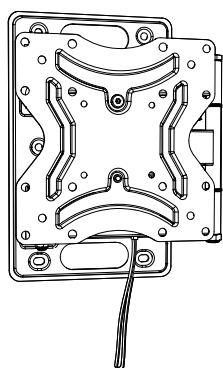

Support TV **01** x1

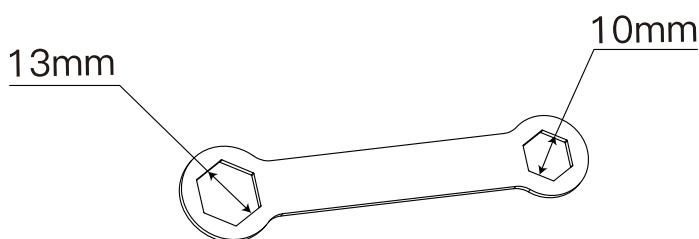

Clé **02** x1

## Étape 1 Déverrouiller le bras et détacher le plastron

1-1 Tirez la sangle vers le bas et éloignez le bras de la plaque murale.

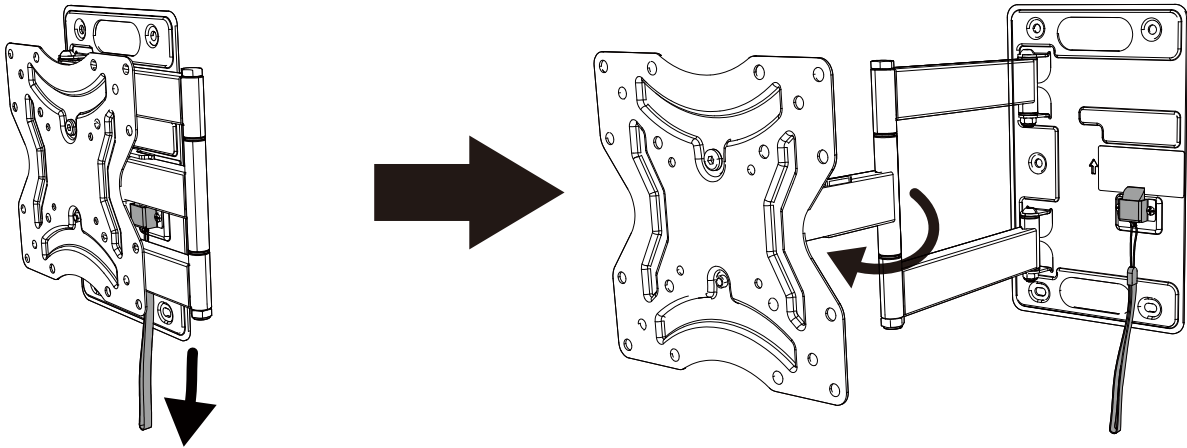

1-2 Dévisser légèrement mais PAS retirer l'écrou [S2] avec la clé [02].

1-3 Retirer le boulon [S1] à l'aide de la clé [02] ou d'un tournevis fourni et le conserver pour l'utiliser à l'étape 4-2 de la page 27.

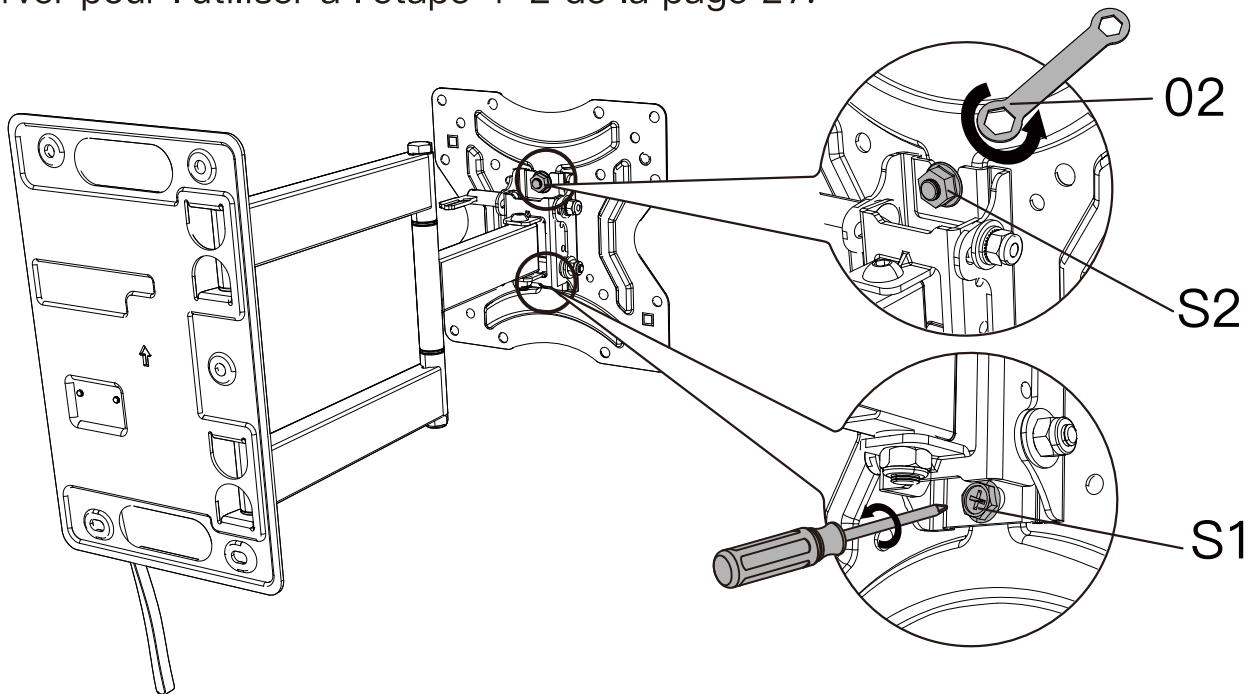

1-4 Séparez le Plaque frontale [01B] de l'Assemblage de bras/plaque murale [01A].

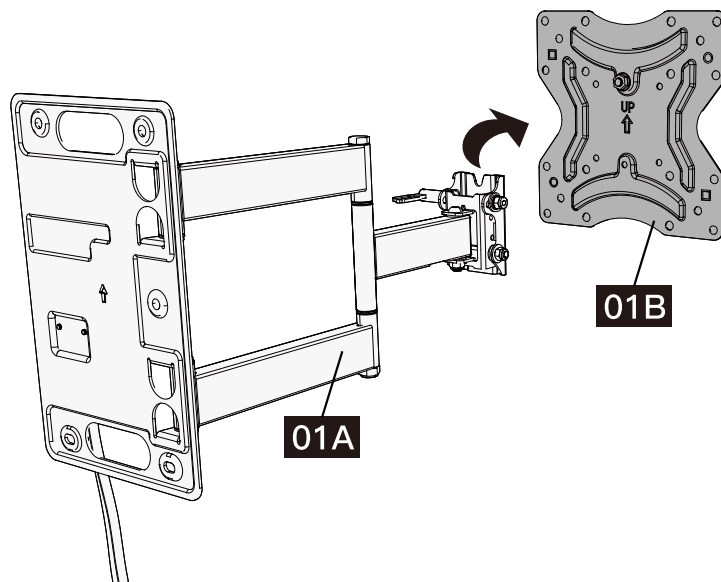

## Pièces et matériel fournis pour l'étape 2

**04** Rondelle

**05** Entretoises [Si nécessaire]

**REMARQUE** : Les rondelles et les entretoises sont indiquées en taille réelle.

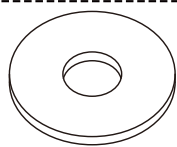

[B1] x4  
M4/M5

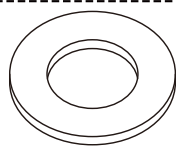

[B2] x4  
M6/M8



[G1] x4  
L2.5mm

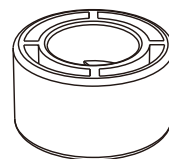

[G2] x8  
L10mm

**06** Boulons de TV [Une seule taille de boulon convient à votre TV]

**REMARQUE** : la vis est représentée à sa taille réelle.

**M4**

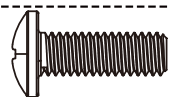

M4 x 12mm  
[C1] x4

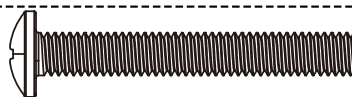

M4 x 30mm  
[C2] x4

**M5**

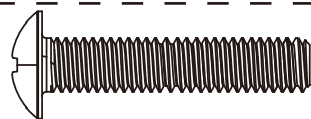

M5 x 25mm  
[D] x4

**M6**

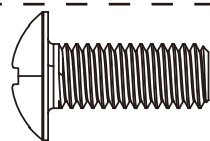

M6 x 15mm  
[E1] x4

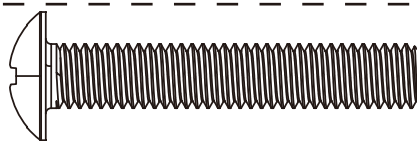

M6 x 35mm  
[E2] x4

**M8**

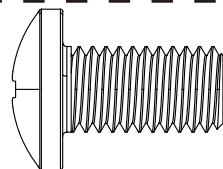

M8 x 15mm  
[F1] x4

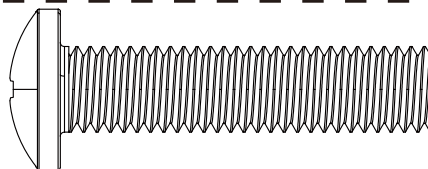

M8 x 35mm  
[F2] x4

## Étape 2 Fixez les Supports TV sur le TV

### Sélectionnez les Boulons de TV

Une seule taille de boulon convient à votre TV.

**M4**



OU

**M5**



OU

**M6**

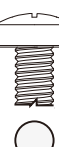

OU

**M8**

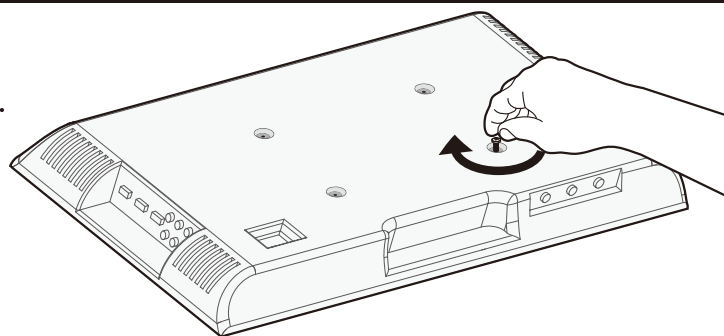

**REMARQUE** : Ne serrez pas trop les boulons de TV pour ne pas l'endommager.  
Longueur de la vis : vérifiez que le filetage est correctement engagé avec les boulons ou la combinaison vis/entretoises. Nous recommandons un engagement du filetage sur au moins 5 tours.

- Trop court, le TV ne sera pas maintenu.
- Trop long, le TV sera endommagé.

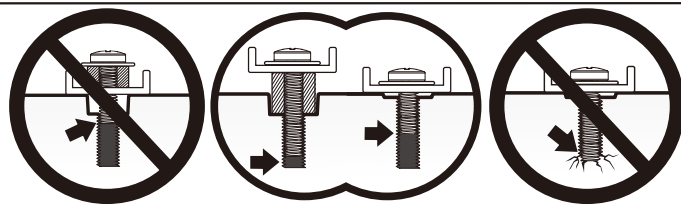

Trop court

Correct

Trop long

**Veillez noter :** Lors de l'utilisation des entretoises, il est important de noter qu'elles peuvent être utilisées sur plusieurs couches (c'est-à-dire empilées). Si vous rencontrez des difficultés pour comprendre comment installer les boulons ou les entretoises du téléviseur, veuillez contacter notre service d'assistance technique au (877) 419-7832 ou notre service clientèle à l'adresse support@ergoav.com.

**Les pièces nécessaires si vous avez un TV tel qu'indiqué ci-après**

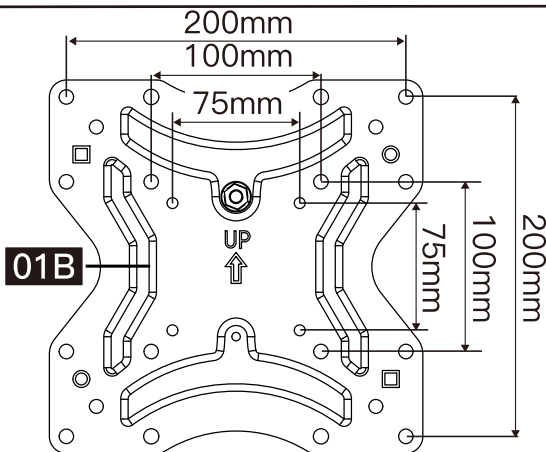
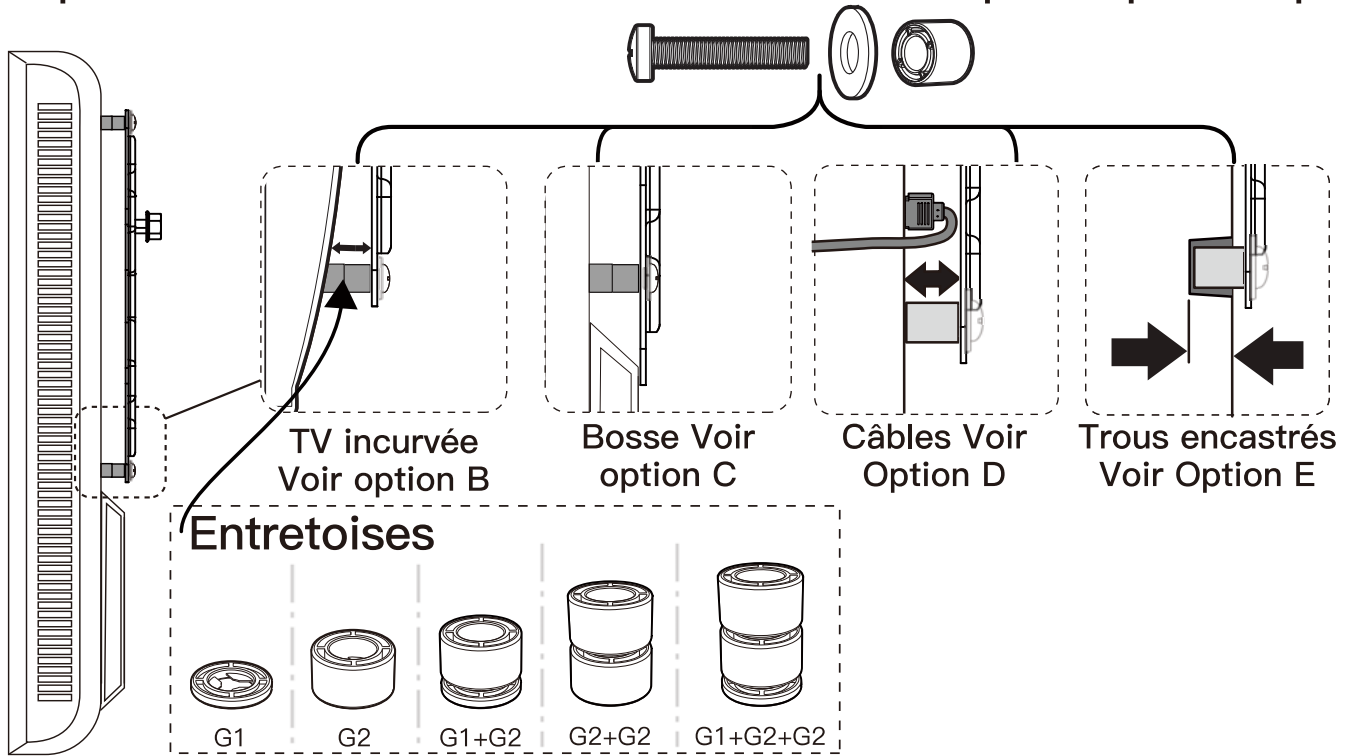

Pour le modèle VESA:

75mm x 75mm ≈ 3 x 3 pouce

100mm x 100mm ≈ 3.9 x 3.9 pouce

200mm x 100mm ≈ 7.9 x 3.9 pouce

200mm x 200mm ≈ 7.9 x 7.9 pouce

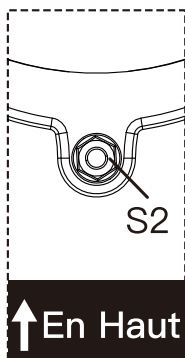
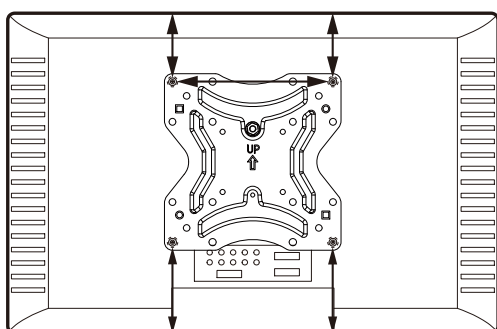

↑ En Haut

**⚠ ATTENTION :** Lorsque vous fixez la façade [01B] à l'arrière du Téléviseur, assurez-vous que l'écrou préassemblé [S2] est orienté vers le haut du Téléviseur et qu'il est également centré à l'arrière du Téléviseur.

**⚠ VEUILLEZ NOTER :** les emplacements des trous des boulon sur votre TV peuvent varier en fonction du modèle du fabricant du TV. Nous représentons seulement les emplacements possibles des trous des vis.

## Option A (pour les TV à dos plat)



Tournevis Phillips  
(Non inclus)

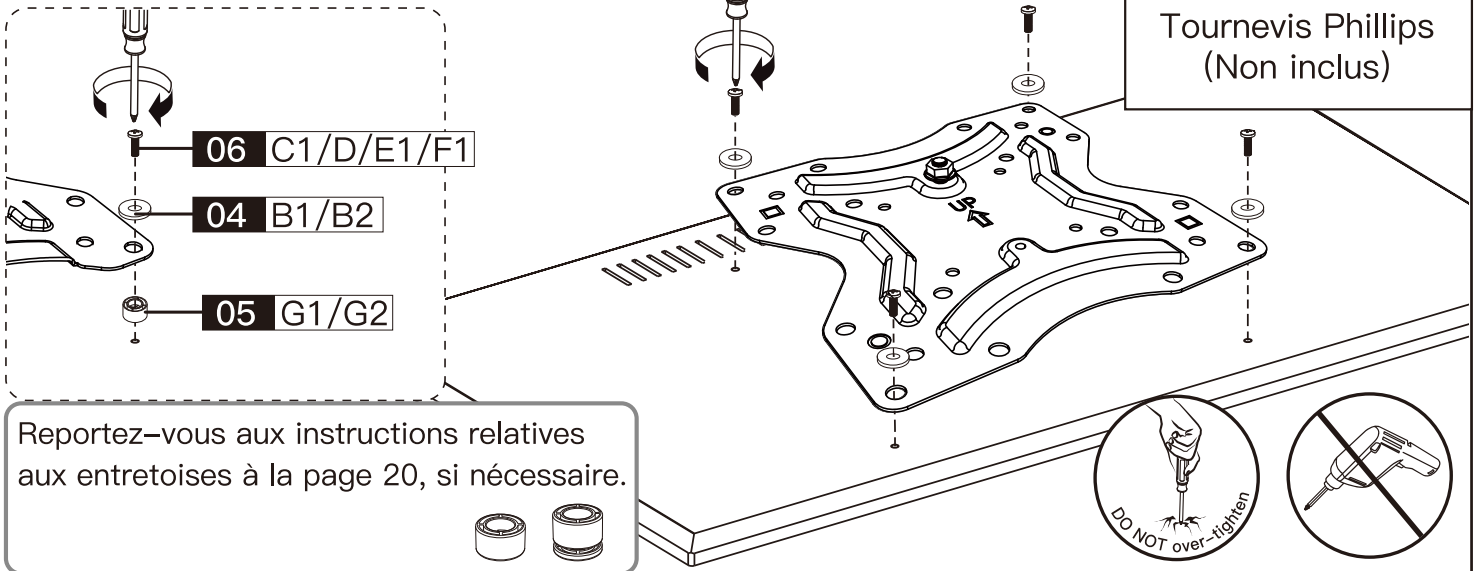

Reportez-vous aux instructions relatives aux entretoises à la page 20, si nécessaire.



## Option B (pour les TV à dos incurvé)



Tournevis Phillips  
(Non inclus)

La hauteur des entretoises doit être suffisante pour éviter que la courbe à l'arrière du TV n'interfère avec la plaque de montage.

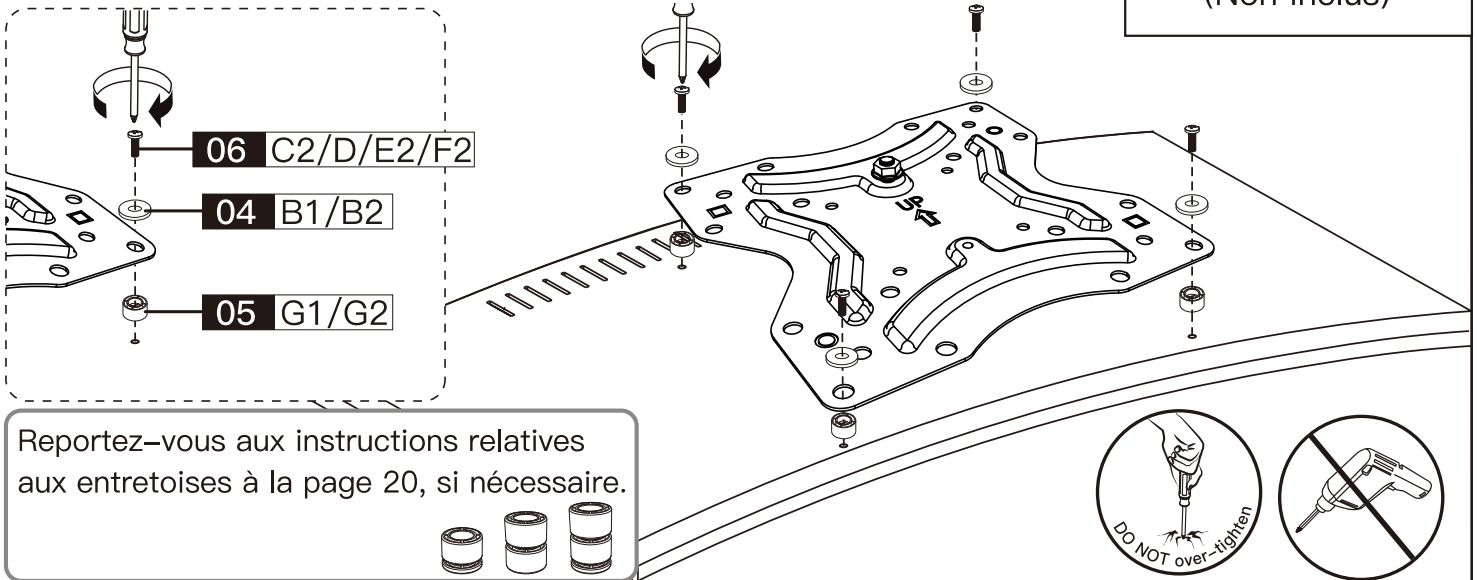

Reportez-vous aux instructions relatives aux entretoises à la page 20, si nécessaire.



## Option C (pour les TV avec une "bosse")

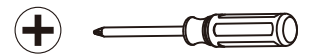

Tournevis Phillips  
(Non inclus)

Les entretoises doivent être suffisamment hautes pour qu'il n'y ait pas d'espace entre la plaque frontale et la bosse à l'arrière du Téléviseur.

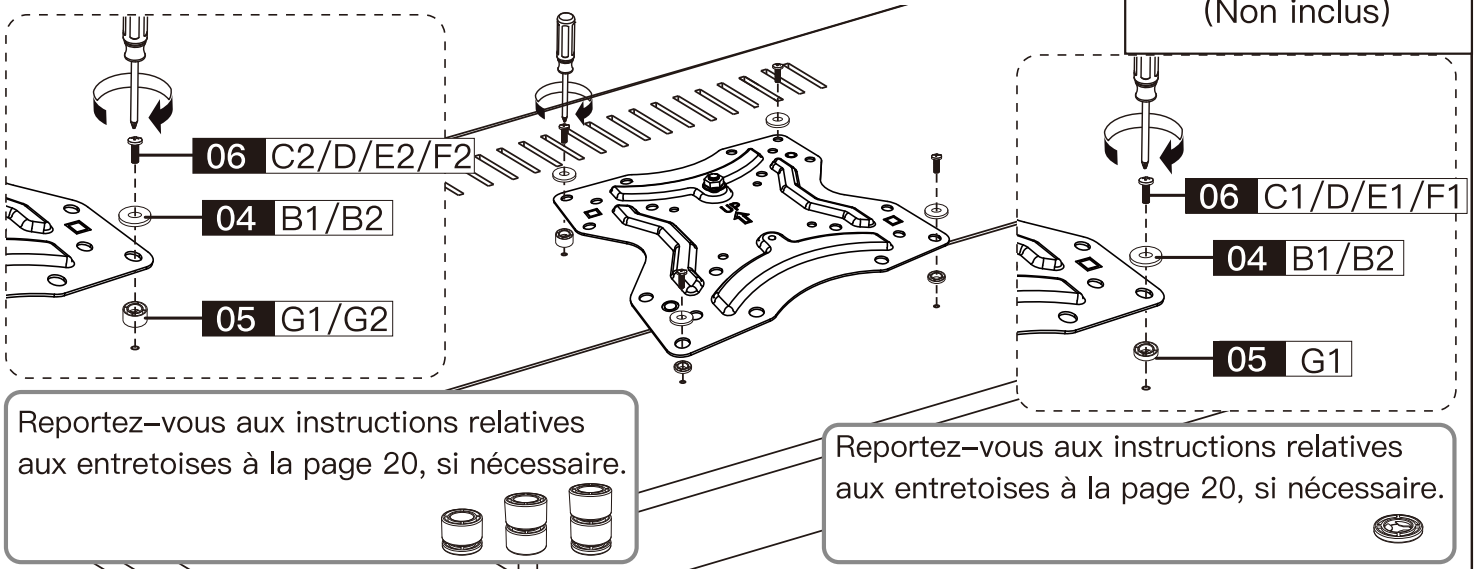

Reportez-vous aux instructions relatives aux entretoises à la page 20, si nécessaire.



Reportez-vous aux instructions relatives aux entretoises à la page 20, si nécessaire.





## Option D (pour téléviseur avec interférence du câble)

Pour éviter les interférences entre les câbles, utilisez les entretoises [G1] et [G2] pour créer un espace supplémentaire entre le téléviseur et les supports TV.



Tournevis Phillips  
(Non inclus)

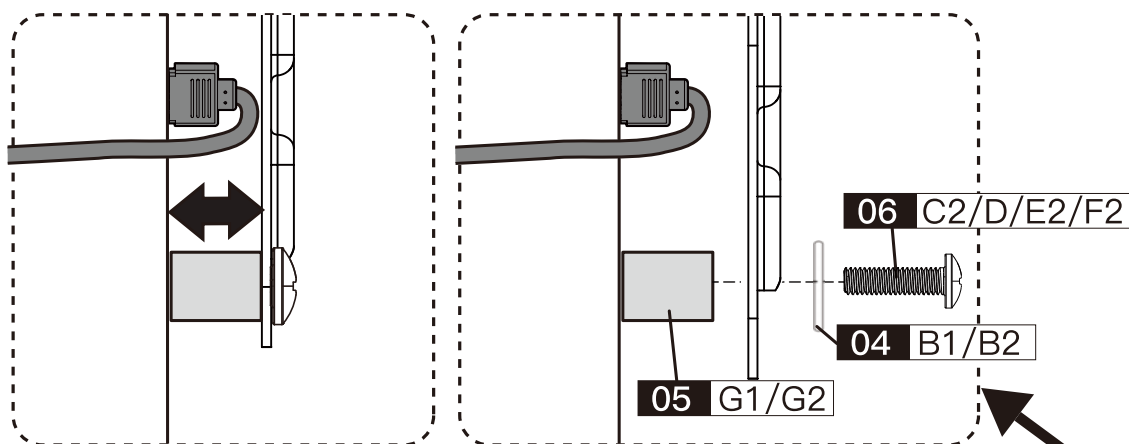

Reportez-vous aux instructions relatives aux entretoises à la page 20, si nécessaire.

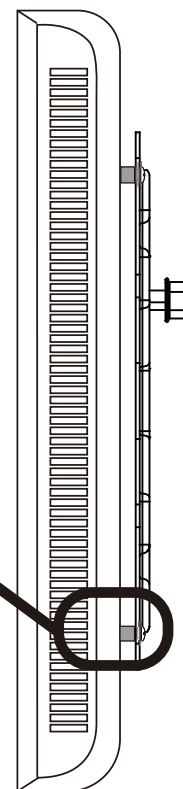
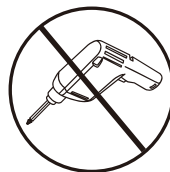

## Option E (Pour les trous encastrés)

L'entretoise doit remplir les trous en retrait sur la base du téléviseur afin que les supports TV soient aussi proches que possible du téléviseur.



Tournevis Phillips  
(Non inclus)

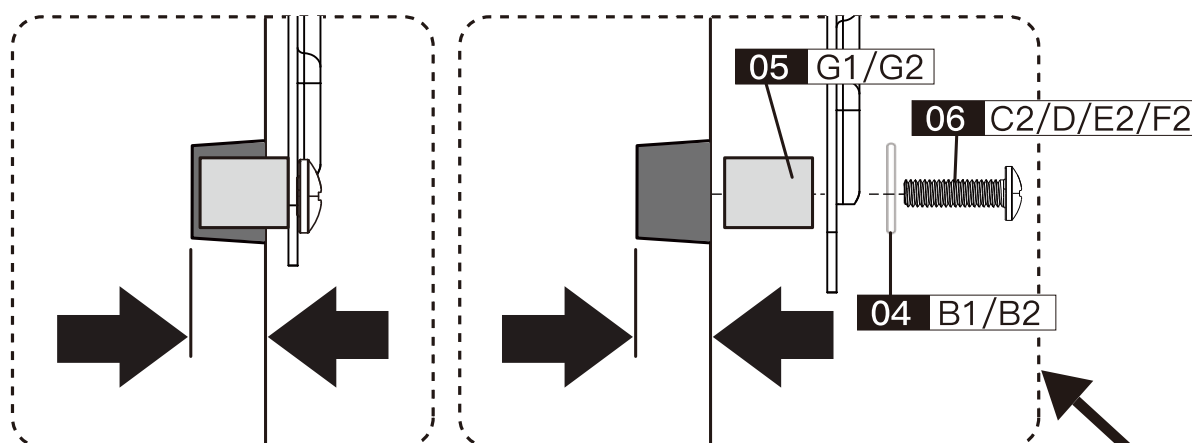

Reportez-vous aux instructions relatives aux entretoises à la page 20, si nécessaire.

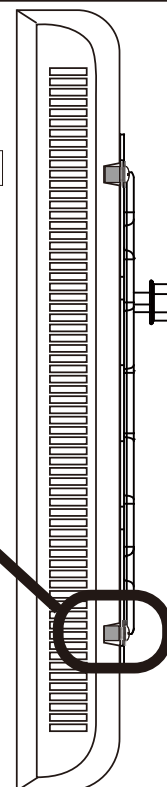



## Pièces et matériel fournis pour l'étape 3

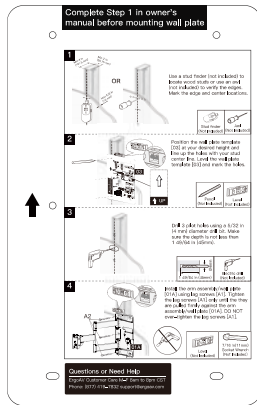

**03** x1  
Modèle de mur

**A1**

x5

Tire-fond  
1/4 x 1 3/4 pouce



**A2**

x5

Ancre  
de mur  
8x40mm

**! ATTENTION!**

Cet ancrage est destiné aux murs en béton UNIQUEMENT. NE PAS les utiliser dans des cloisons sèches ou les montants en bois.



## Étape 3 Fixation de l'Assemblage de bras / Plaque murale [03] au mur

Pour l'installation de montants en bois, suivre l'ÉTAPE 3A

Pour l'installation de béton, suivre l'ÉTAPE 3B

### Étape 3A Option montants en bois

#### **! AVERTISSEMENT :**

N'utilisez pas de perceuse pour serrer les tire-fonds ! Utilisez uniquement une clé à douille.

#### **! ATTENTION :**

Si l'installation se fait dans un VR, avant de percer, assurez-vous que l'épaisseur de votre mur est supérieure à 2 pouce.



● NE PAS UTILISER L'ANCRAGE [A2] POUR CETTE ÉTAPE.

● Assurez-vous que la plaque murale est bien fixée au mur avant de passer à l'étape suivante.

● Taille nominale des montants en bois : commun 2 x 4 pouce (51 x 102 mm)

● Le centre des montants doit être vérifié.

### 3A-1

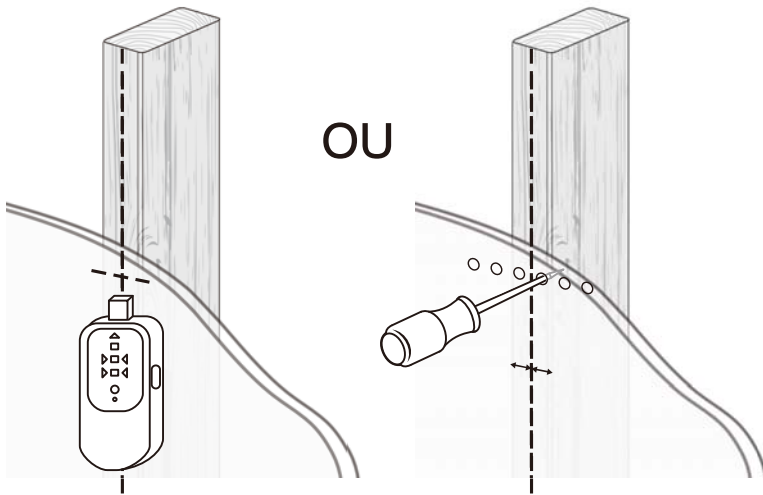

Utilisez un détecteur de montants (non inclus) pour localiser les montants en bois ou utilisez une alène (non incluse) pour vérifier les bords. Marquez les emplacements du bord et du centre.

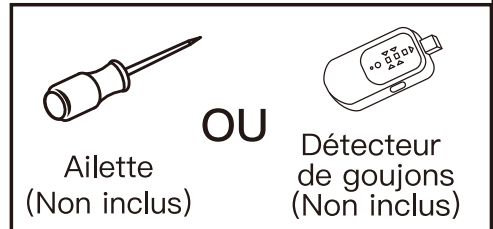

### 3A-2

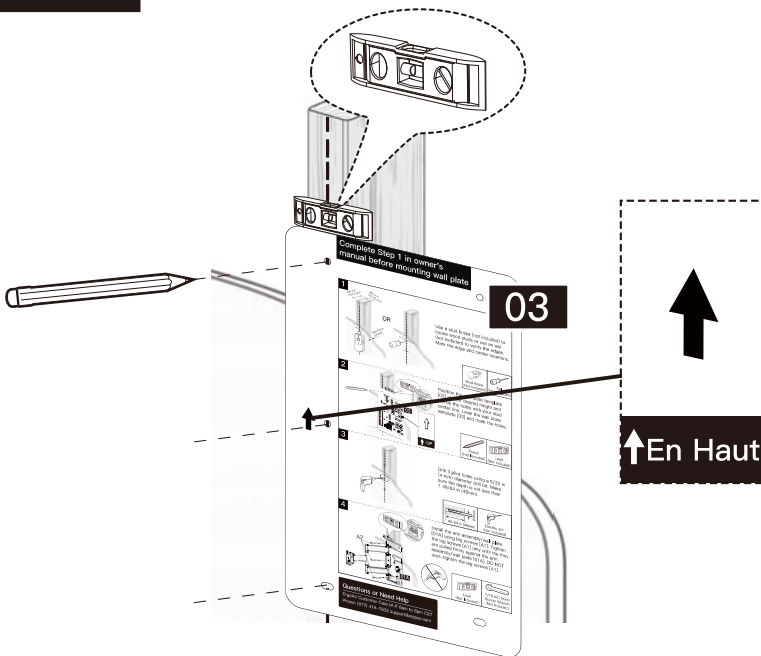

Positionnez le modèle de plaque murale [03] à la hauteur souhaitée et alignez les trous avec la ligne centrale de votre montant. Mettez à niveau le modèle de plaque murale [03] et marquez les trous.

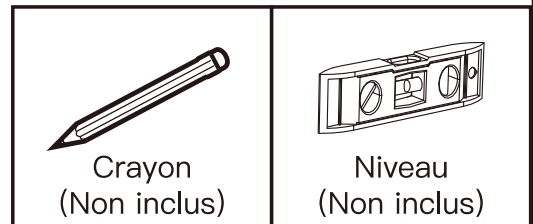

### 3A-3

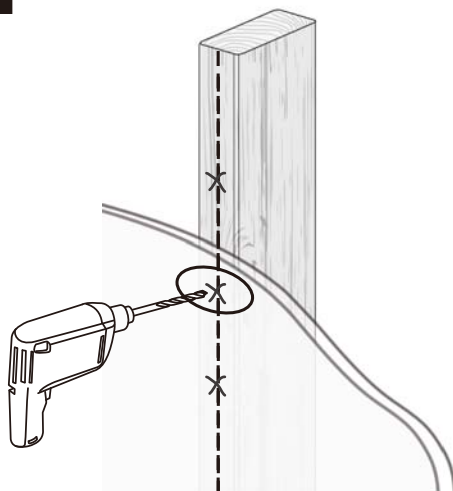

Percez 3 trous pilotes à l'aide d'un foret de 5/32 pouce (4 mm) de diamètre. Assurez-vous que la profondeur des trous n'est PAS inférieure à 1 3/4 pouce (45 mm).

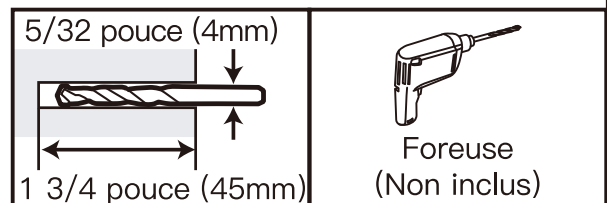

### 3A-4

**⚠ Remarque :** N'utilisez pas de perceuse pour serrer les tire-fonds. Utilisez uniquement une clé à douille.



**LOURD !** vous aurez peut-être besoin d'aide pour cette étape.

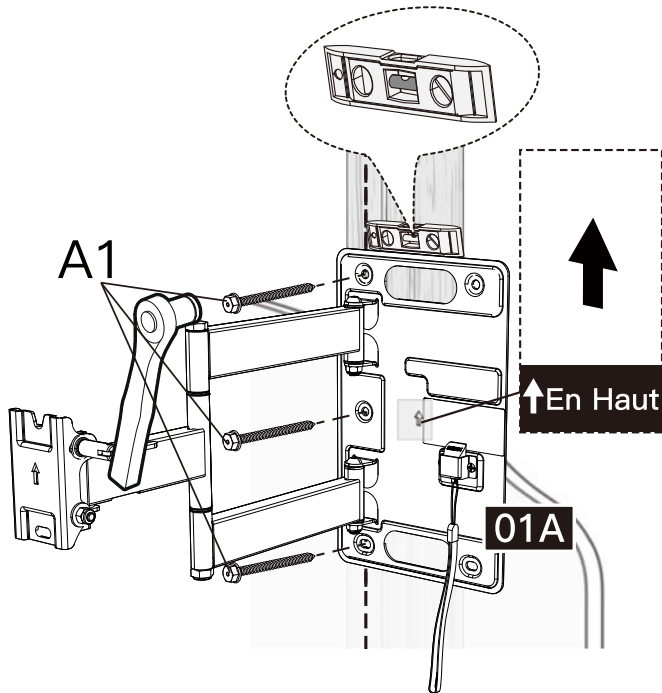

Installez l'Assemblage de bras / Plaque murale [01A] à l'aide des tire-fonds [A1]. Serrez les tire-fonds [A1] jusqu'à ce qu'ils soient fermement tirés contre l'Assemblage de bras / Plaque murale [01A]. **NE SERREZ PAS** trop les tire-fonds [A1].

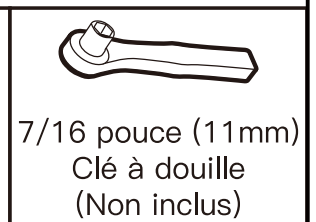
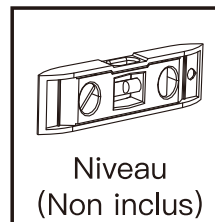
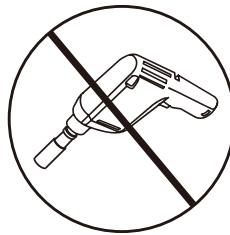

## Étape 2B Option de mur en béton massif

### ⚠ AVERTISSEMENT :

**N'UTILISEZ pas de perceuse pour serrer les tire-fonds !** Utilisez uniquement une clé à douille.

● Évitez tout risque de blessure ou de dommage matériel ! **NE PAS** trop serrer les tire-fonds [A1]. Ne serrez les tire-fonds [A1] que jusqu'à ce qu'ils soient fermement tirés contre la plaque murale.

● Assurez-vous que la plaque murale est bien fixée au mur avant de passer à l'étape suivante.

● Montez la plaque murale directement sur la surface en béton sans aucun revêtement.

● L'épaisseur du mur en béton doit dépasser 5,5 pouce (140 mm).



**A3**  
Wall  
Anchor

### 3B-1

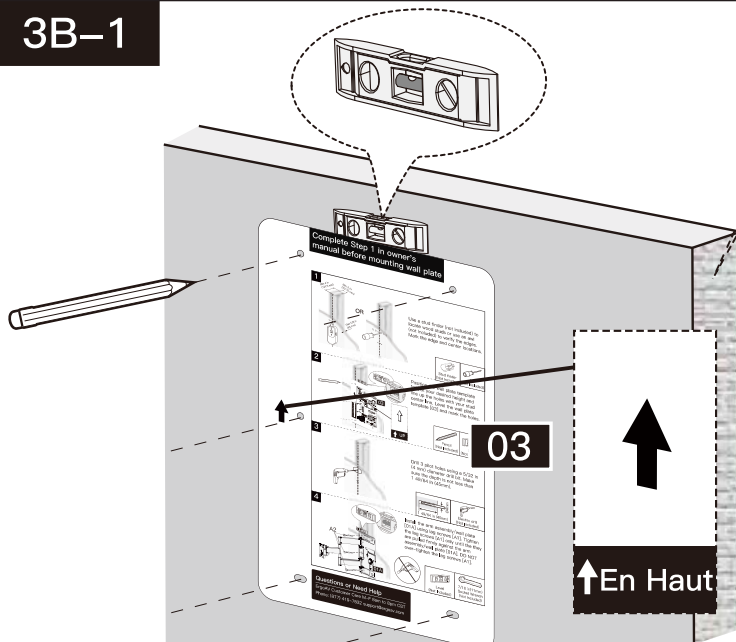

Épaisseur du mur  
≥ 5 1/2 pouce (140 mm)

Positionnez le modèle de plaque murale [03] à la hauteur souhaitée. Mettez à niveau le modèle de plaque murale [03] et marquez les emplacements des avant-trous.

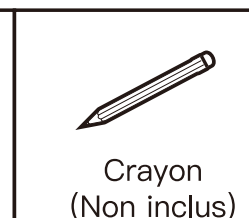
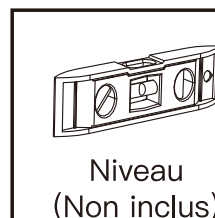

### 3B-2

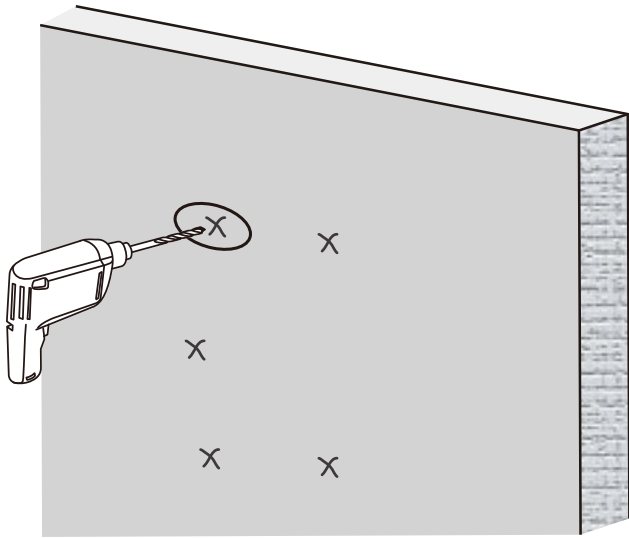

Percez 5 trous pilotes à l'aide d'un foret de 5/16 pouce (8 mm) de diamètre. Assurez-vous que la profondeur n'est pas inférieure à 2 pouce (50 mm).

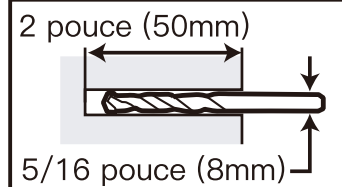

### 3B-3

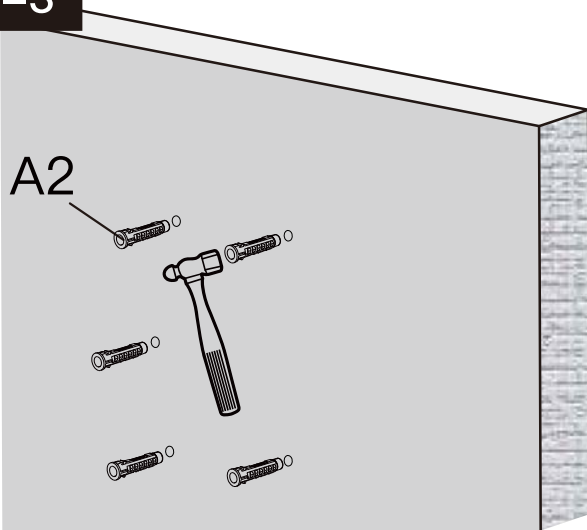

Utilisez le marteau pour enfoncer les ancrages [A3] dans le mur. Veillez à ce que les ancrages [A3] soient posés au ras de la surface du béton.

### 3B-4

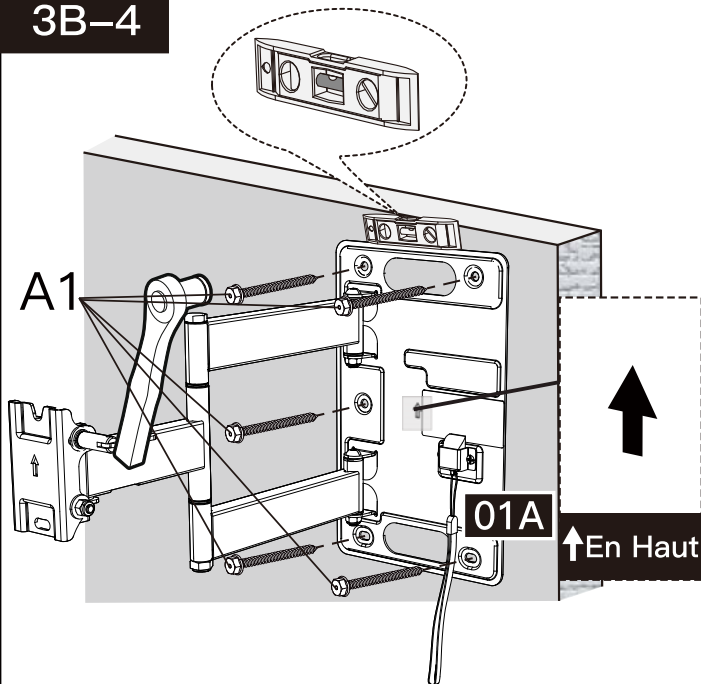

**⚠ Remarque :** N'utilisez pas de perceuse pour serrer les tire-fonds. Utilisez uniquement une clé à douille.

Installez l'ensemble bras/plaque murale [01A] à l'aide de 5 vis de blocage [A1]. Ne serrez les tire-fonds [A1] que jusqu'à ce qu'ils soient fermement tirés contre l'ensemble bras/plaque murale [01A]. NE PAS trop serrer les tire-fonds [A1].

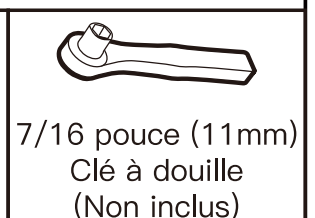
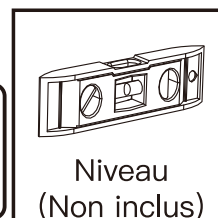
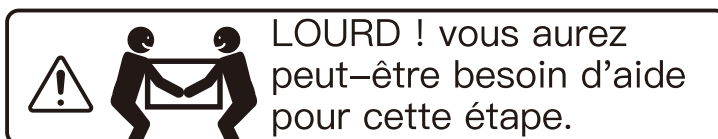

## Étape 4 Accrochez le Téléviseur sur l'assemblage de bras/plaque murale [01A].



**LOURD !** vous aurez peut-être besoin d'aide pour cette étape.



Tournevis Phillips  
(Non inclus)

**4-1** Accrochez le Téléviseur à l'assemblage de bras/plaque murale [01A], en veillant à ce que l'écrou préassemblé [S2] soit suspendu à l'intérieur du crochet de l'assemblage de bras /plaque murale [01A].

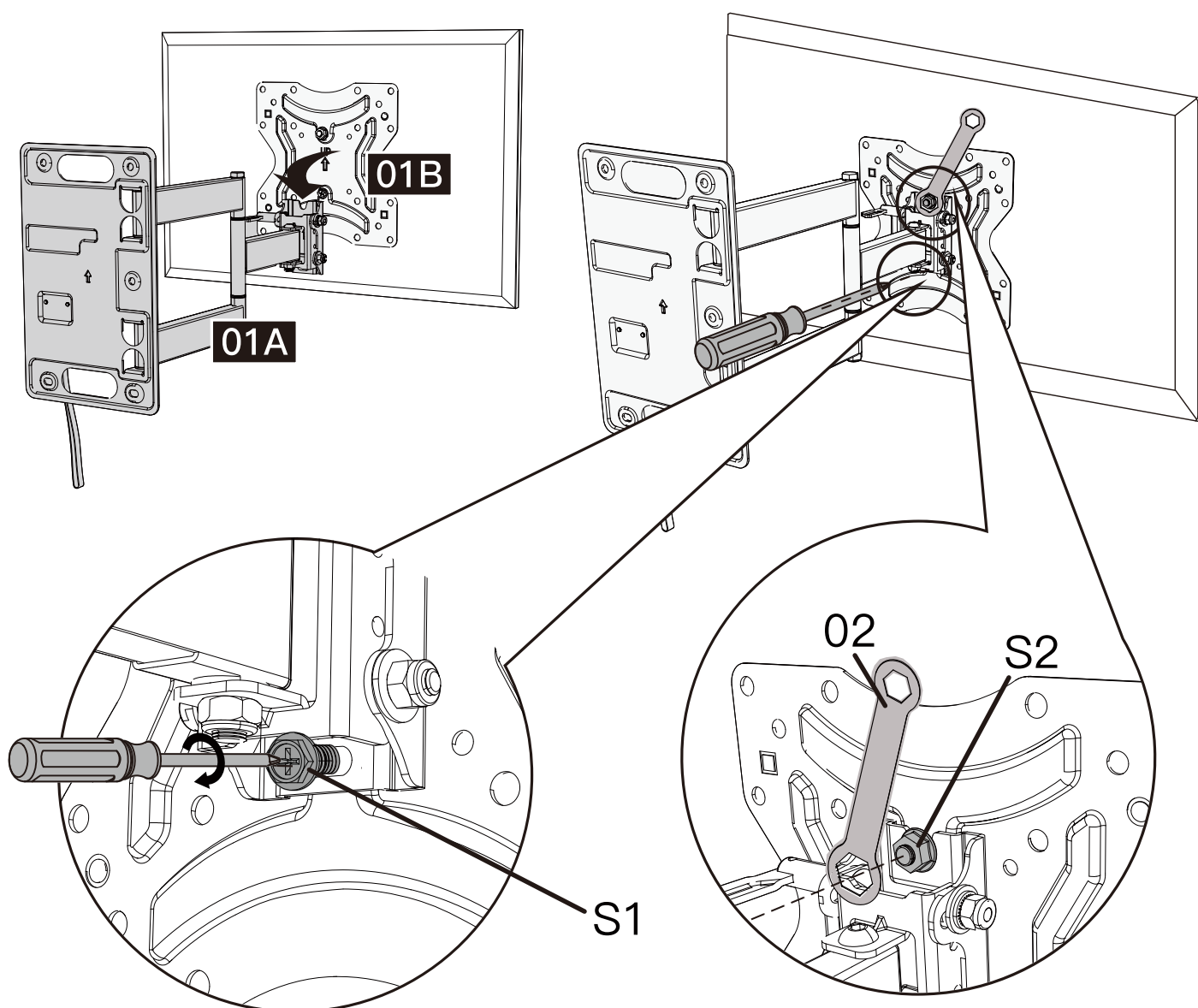

**4-2** Installer et serrer le boulon [S1] retiré à l'étape 1-3 pour fixer le Téléviseur à l'assemblage de bras/plaque murale [01A].

**4-3** Serrez l'écrou [S2].



## Étape 5 Réglages

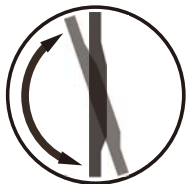

### Réglage de l'inclinaison

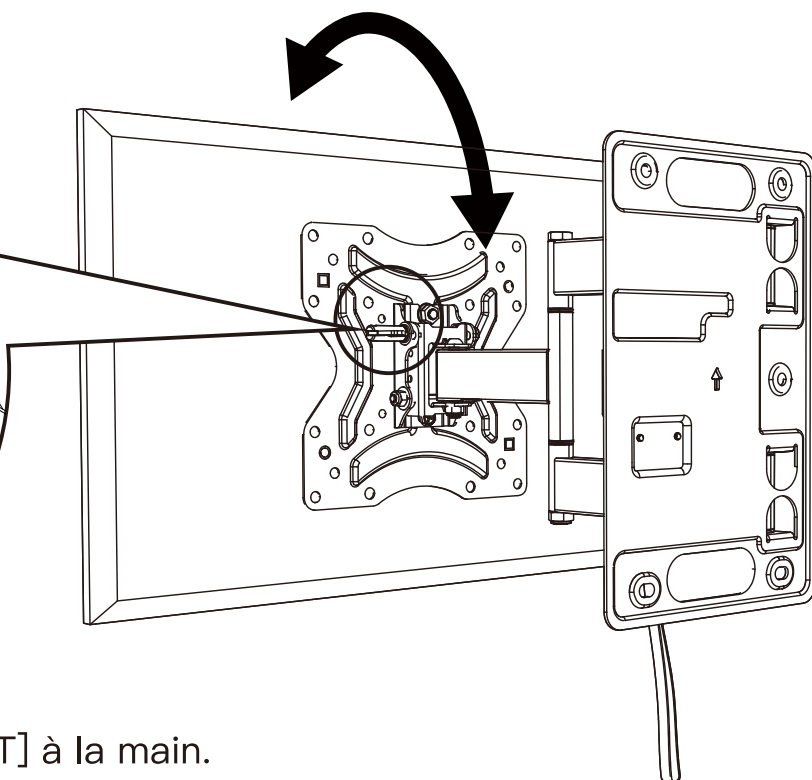
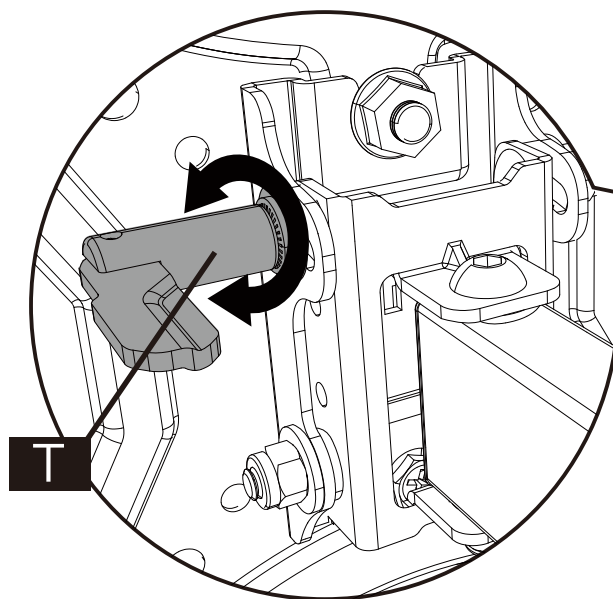

1. Desserrez doucement le Levier [T] à la main.
2. Réglez le téléviseur selon l'angle souhaité.
3. Serrez le Levier [T] pour fixer le Téléviseur.



Si nécessaire, le Téléviseur peut être mis à niveau.



Tournevis Phillips  
(Non inclus)

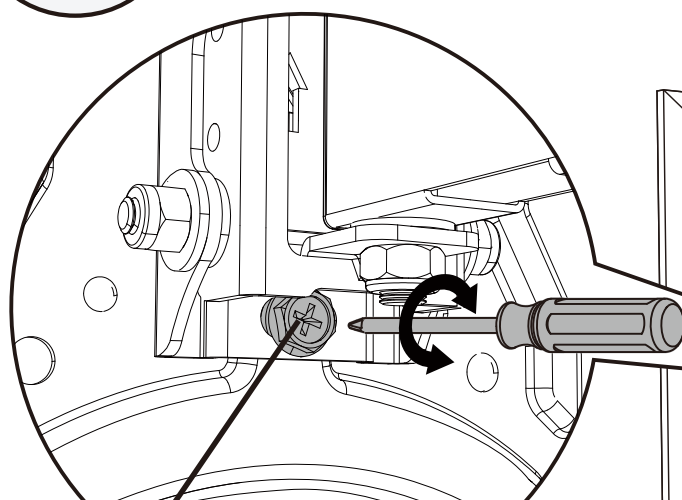

### S1 Boulon de mise à niveau

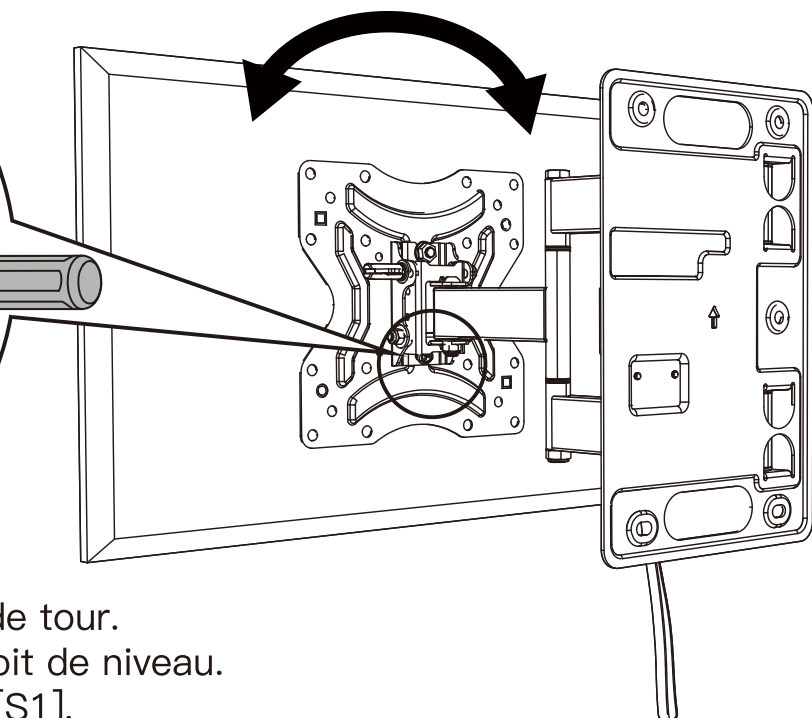

1. Desserrez le boulon [S1] d'1/4 de tour.
2. Réglez le Téléviseur pour qu'il soit de niveau.
3. Resserrez fermement le boulon [S1].



## Étape 6 Rangement du Téléviseur

**6-1** Pour ranger votre Téléviseur contre le mur, poussez doucement le Téléviseur contre le mur tout en maintenant la sangle vers le bas. Une fois que le Téléviseur est contre le mur, relâchez la sangle et vérifiez que le Téléviseur est maintenu en place par le loquet.

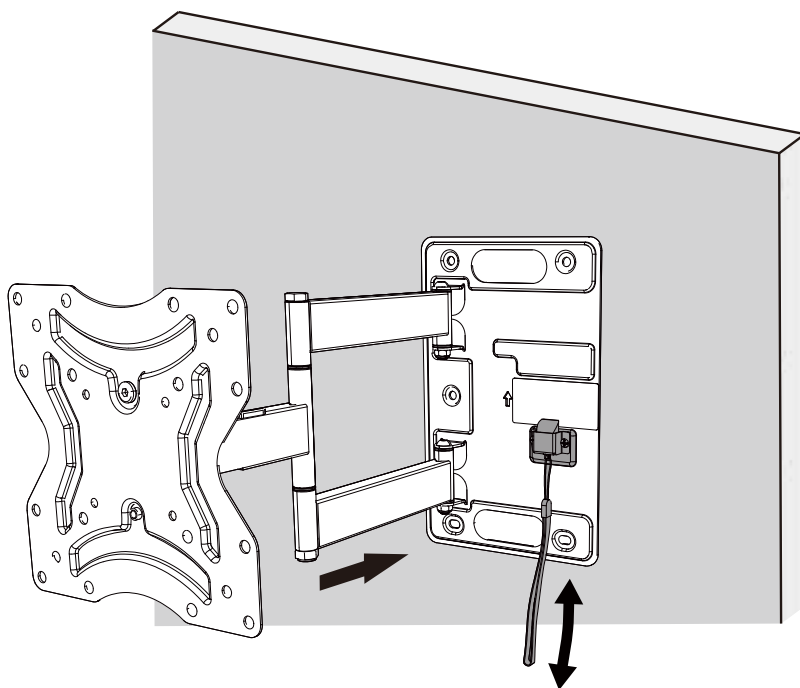

**6-2** Pour libérer le Téléviseur de sa position de rangement, poussez-le doucement contre le mur et tirez sur la sangle vers le bas. Une fois que le Téléviseur est éloigné du mur, relâchez la sangle.

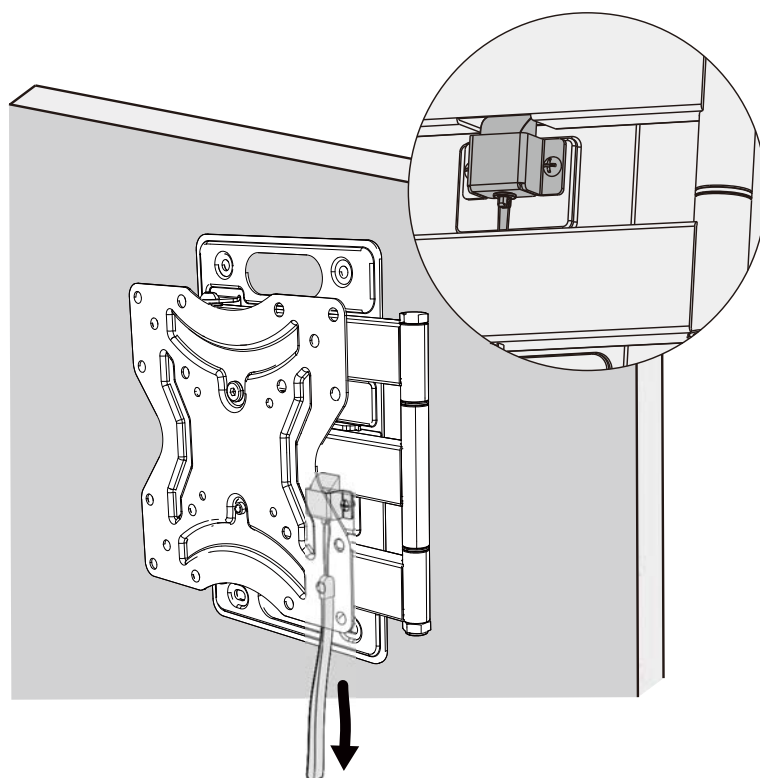

## INFORMACIÓN IMPORTANTE DE SEGURIDAD

**⚠ ¡PELIGRO!** Por favor, lea cuidadosamente todas las instrucciones antes de realizar la instalación. Si no entiende las instrucciones o tiene alguna duda o consulta, póngase en contacto con nuestra línea de asistencia técnica llamando al (877) 419-7832, o escribiendo al servicio de atención al cliente en [support@ergoav.com](mailto:support@ergoav.com).

**⚠ PRECAUCIÓN:** El uso con productos más pesados que los pesos máximos indicados puede causar inestabilidad causando posibles lesiones.

- No utilice este producto con ningún fin que no sea el especificado explícitamente en este manual. No supere la capacidad de peso. No nos hacemos responsables de posibles daños o lesiones causados por un montaje incorrecto, errores de ensamblaje o uso inadecuado.
- Este producto está diseñado para usarse en paredes de vigas de madera, concreto sólido y bloques de concreto. NO lo instale solo en paneles de yeso. Tenga en cuenta: al instalar en un vehículo recreativo, consulte con nuestro servicio de atención al cliente en [support@ergoav.com](mailto:support@ergoav.com) para determinar la profundidad correcta del tornillo que debe usar para su instalación.
- La pared debe ser capaz de soportar cuatro veces el peso del televisor y del soporte juntos.
- Utilice este sistema de montaje sólo para el uso previsto, tal como se describe en estas instrucciones. No utilice accesorios no recomendados por el fabricante.
- No lo utilice en el exterior.
- Coloque los cables de forma apropiada para evitar daños mecánicos.
- **GUARDE ESTAS INSTRUCCIONES**

## Límites de peso



Si su televisor excede el peso, no utilice este producto.

### ⚠ ADVERTENCIA

NO exceda el peso máximo indicado. Este módulo para televisor solo debe usarse dentro de los pesos máximos indicados. Si se usa con productos que exceden los pesos máximos indicados es posible que se produzca una falla en el módulo para televisor y sus accesorios, posiblemente provocando daños y/o lesiones.

## Revise el patrón VESA de la TV antes de la instalación

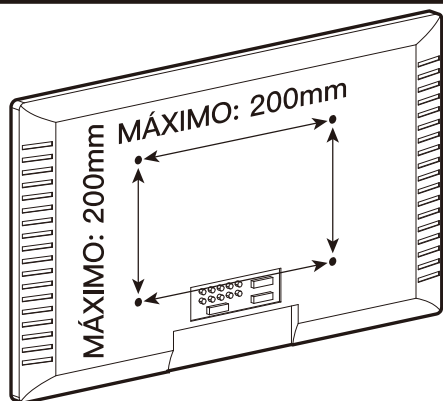

Para patrones VESA:

75mm x 75mm ≈ 3 x 3 pulg

100mm x 100mm ≈ 4 x 4 pulg

200mm x 100mm ≈ 7 7/8 x 4 pulg

200mm x 200mm ≈ 7 7/8 x 7 7/8 pulg

Mínimo: 75mm x 75mm / 3 x 3 pulg (W x H)

Máximo: 200mm x 200mm / 7 7/8 x 7 7/8 pulg (W x H)

Si el patrón VESA de su Televisor es inferior a 75 mm x 75 mm o superior a 200mm x 200mm, significa que este soporte NO ES COMPATIBLE. Póngase en contacto con nuestro Servicio Técnico llamando al (877) 419-7832 o escribiendo a [support@ergoav.com](mailto:support@ergoav.com).

## Herramientas necesarias (no incluidas)

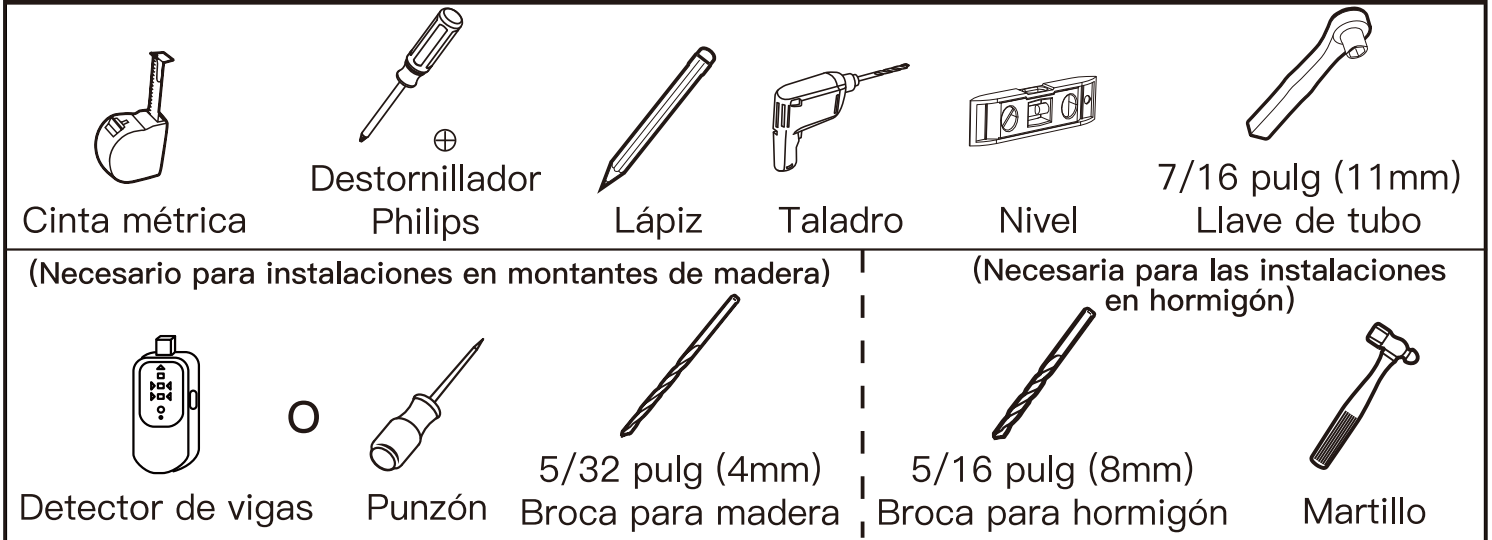

## Inspeccione la construcción de su pared

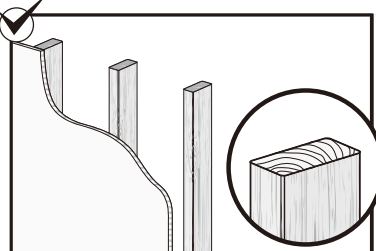
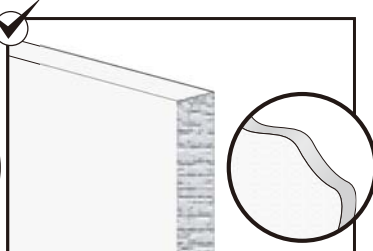
 <b>PRECAUCIÓN</b> NO instalar solo en placa de yeso			Si no está seguro sobre las condiciones de construcción de su pared, póngase en contacto con nuestra línea de asistencia técnica en el (877) 419-7832 o con el servicio de atención al cliente en <a href="mailto:support@ergoav.com">support@ergoav.com</a> .
	Montantes de madera (con placa de yeso)	Pared de hormigón sólido	

## Piezas y herramientas provistas

**⚠ ADVERTENCIA:** Este producto contiene piezas pequeñas que pueden representar un riesgo de atragantamiento si se ingieren.

Antes de iniciar el montaje, compruebe que todas las piezas estén incluidas e intactas. NO use piezas dañadas o defectuosas. Si necesita piezas de repuesto, contáctese con el servicio de atención al cliente [support@ergoav.com](mailto:support@ergoav.com).

- **Tenga en cuenta lo siguiente:** Es posible que no necesite usar todos los herrajes incluidos en este envase.

## Piezas y herrajes suministrados para el paso 1

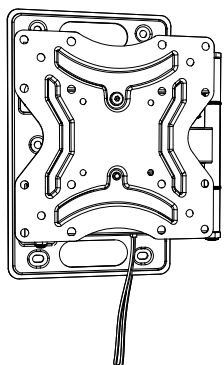

Montaje de televisión **01** x1

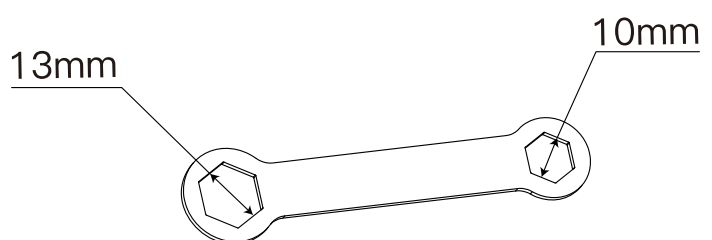

Llave inglesa **02** x1

## passo 1 Desbloquear brazo y separar placa frontal

1-1 Empuje la correa hacia abajo y estire el brazo lejos de la placa de pared.

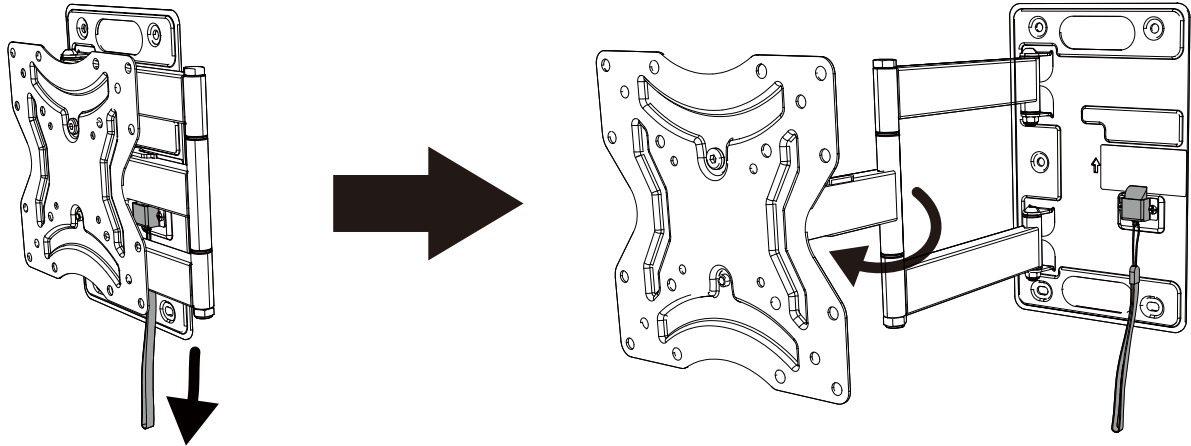

1-2 Destornille un poco pero NO saque la tuerca [S2] con la llave inglesa [02].  
1-3 Retire el perno [S1] con la llave inglesa [02] o con un destornillador propio y guárdelo para usar después en el paso 4-2 de la página 41.

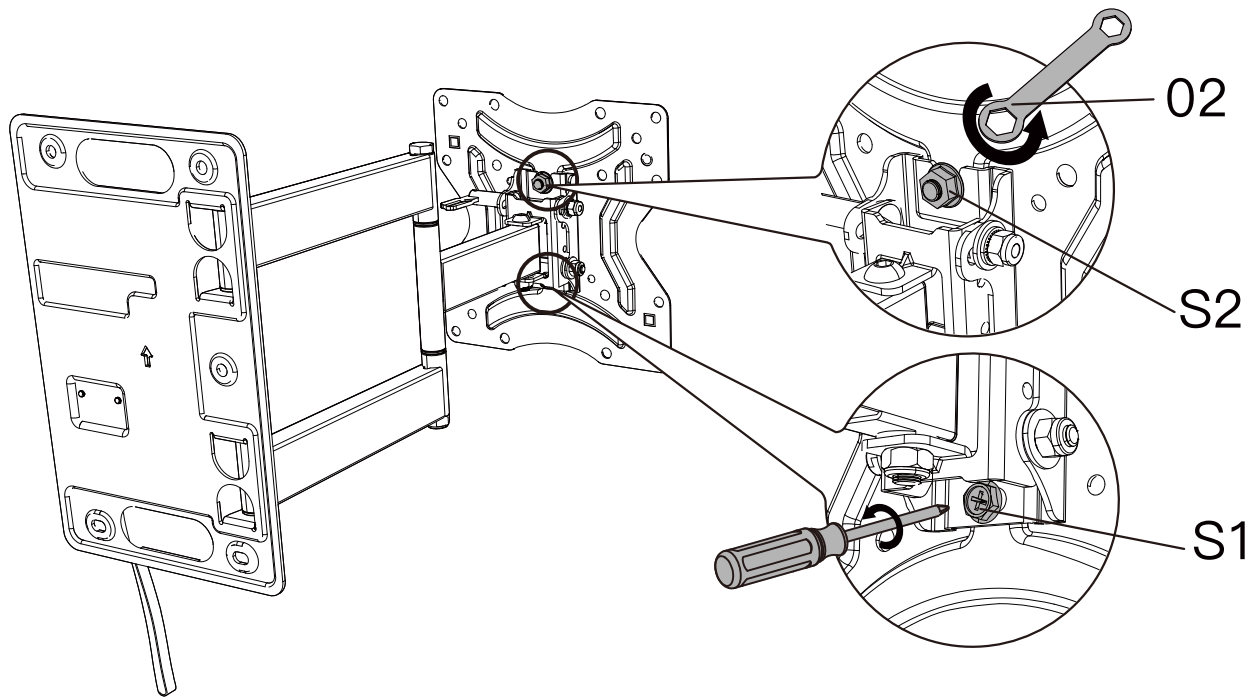

1-4 Separe la placa frontal [01B] del conjunto de brazo/placa de pared [01A].

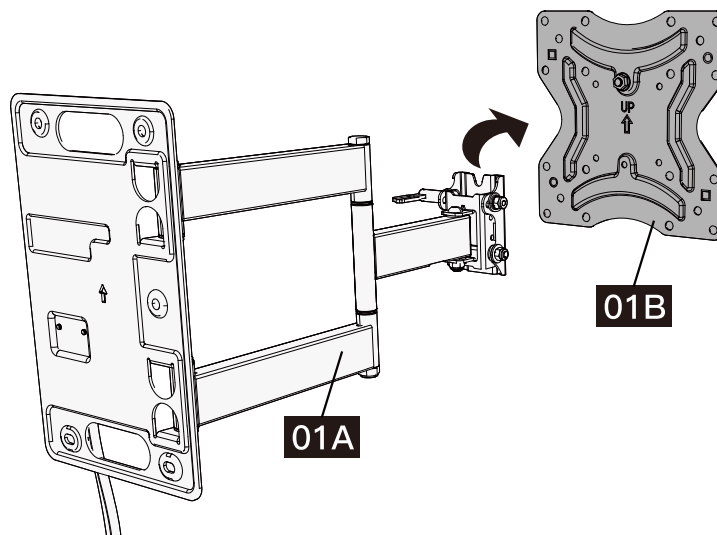

## Piezas y herrajes suministrados para el paso 2

### 04 Arandela

### 05 Espaciadores [De ser necesario]

Nota: Los espaciadores se muestran en tamaño real.

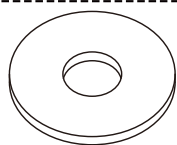

[B1] x4  
M4/M5

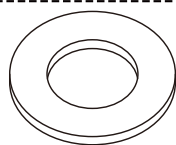

[B2] x4  
M6/M8



[G1] x4  
L2.5mm

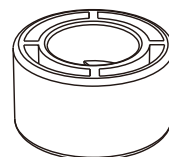

[G2] x8  
L10mm

### 06 Pernos del televisor [Su televisor solo admite uno de los tamaños de perno]

Nota: Los pernos se muestran en tamaño real

#### M4

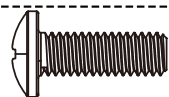

M4 x 12mm  
[C1] x4

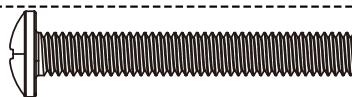

M4 x 30mm  
[C2] x4

#### M5

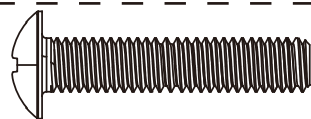

M5 x 25mm  
[D] x4

#### M6

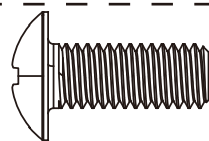

M6 x 15mm  
[E1] x4

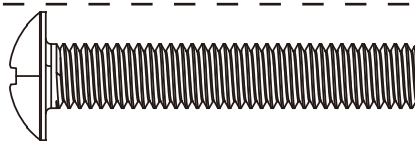

M6 x 35mm  
[E2] x4

#### M8

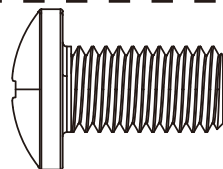

M8 x 15mm  
[F1] x4

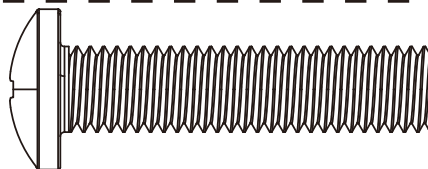

M8 x 35mm  
[F2] x4

## Paso 2 Asegure los soportes de la TV a la TV

### Seleccione los perno para el TV

Su televisor solo admite uno de los tamaños de perno.

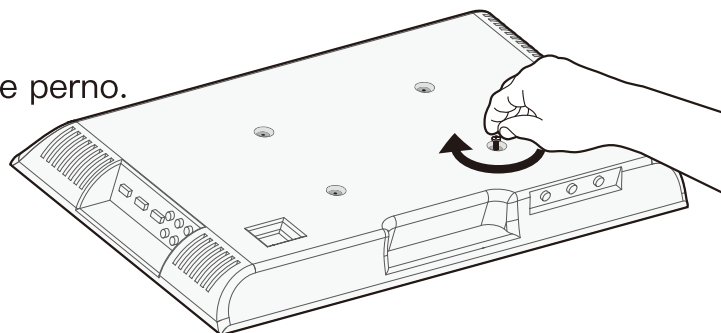
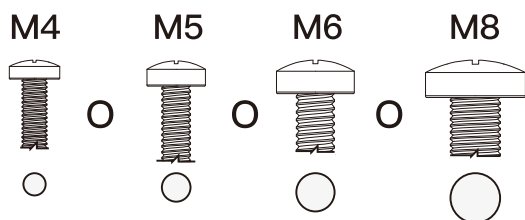

Nota: No ajuste los pernos del televisor en exceso para no dañarlo.

**Longitud del perno:** Compruebe que la rosca encaje correctamente con los pernos o la las combinaciones de pernos/espaciador. Se recomienda enganchar las roscas con 5 vueltas como mínimo.

- Si es demasiado corto, no soportará el TV.
- Si es demasiado largo, hará daños al TV.





Demasiado corto

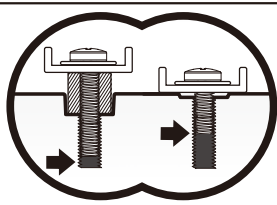

Correcto



Demasiado largo

**NOTA:** Al utilizar espaciadores, es importante tener en cuenta que se pueden utilizar apilados. Si tiene alguna dificultad para comprender el modo de instalación de los pernos o espaciadores del televisor, póngase en contacto con nuestra línea de asistencia técnica al (877) 419-7832 o con el servicio de atención al cliente en support@ergoav.com.

### Piezas necesarias si tiene un televisor como el que se muestra a continuación

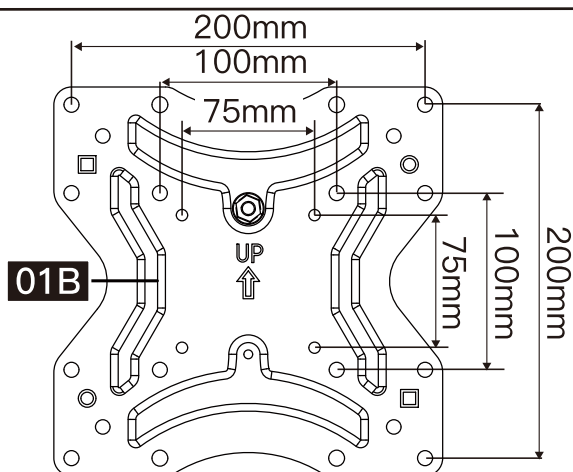
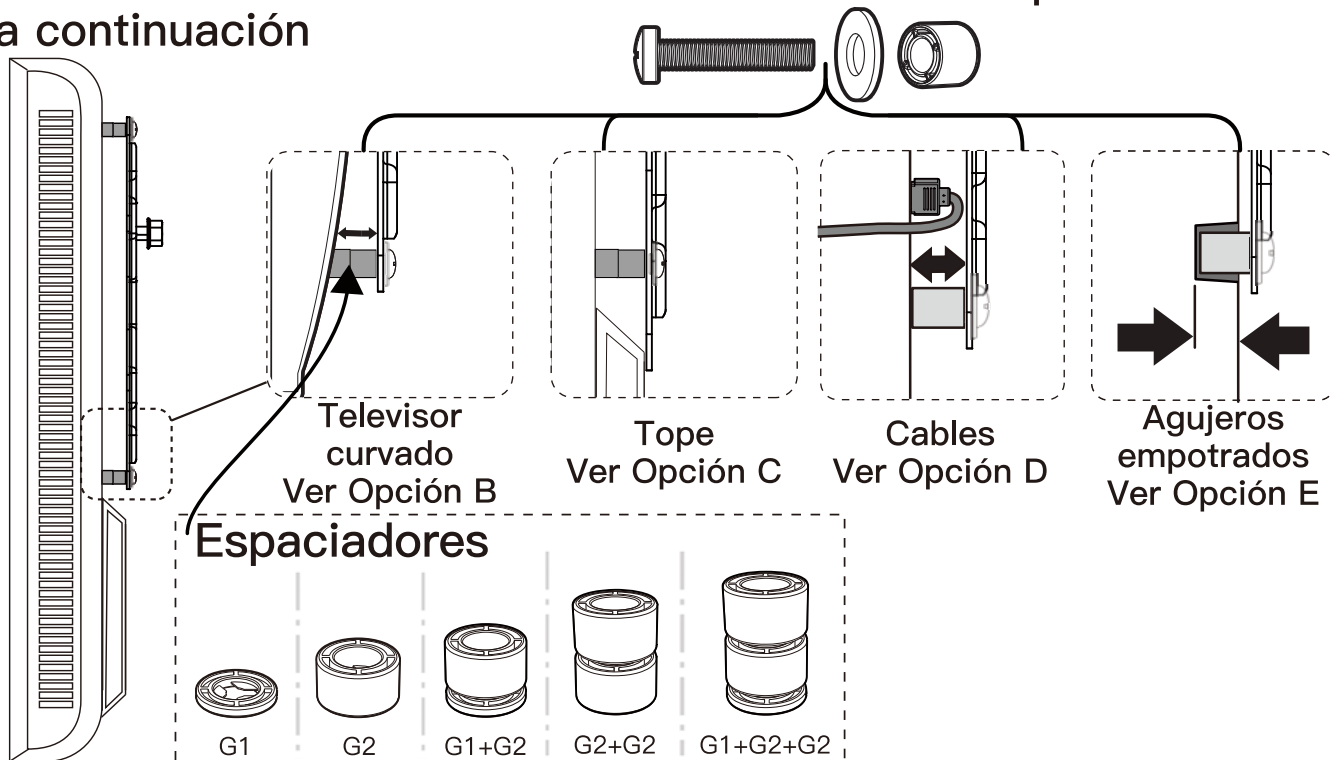

Para patrones VESA:

75mm x 75mm ≈ 3 x 3 pulg

100mm x 100mm ≈ 4 x 4 pulg

200mm x 100mm ≈ 7 7/8 x 4 pulg

200mm x 200mm ≈ 7 7/8 x 7 7/8 pulg

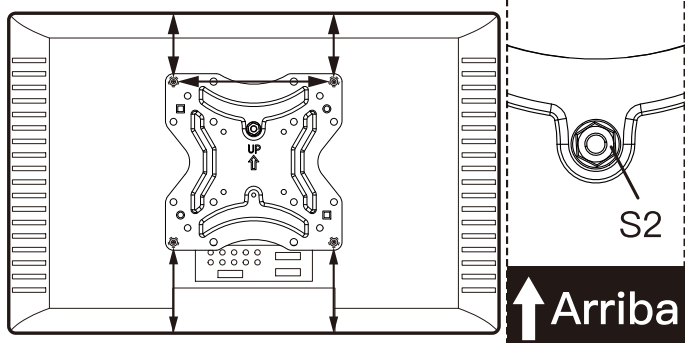

**⚠ PRECAUCIÓN:** Cuando fije la placa frontal [01B] en la parte posterior del Televisor, asegúrese de que la tuerca ya montada [S2] apunte a la parte superior del Televisor y este igualmente centrada en la parte posterior del Televisor.

**⚠ NOTA:** Las ubicaciones de los agujeros para perno de su televisor pueden variar según el diseño del televisor de los fabricantes. Solo ilustramos algunas ubicaciones posibles de dichos agujeros de los pernos.

### Opción A (Para televisores con la parte trasera plana)

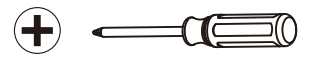

Destornillador Philips  
(No incluidas)

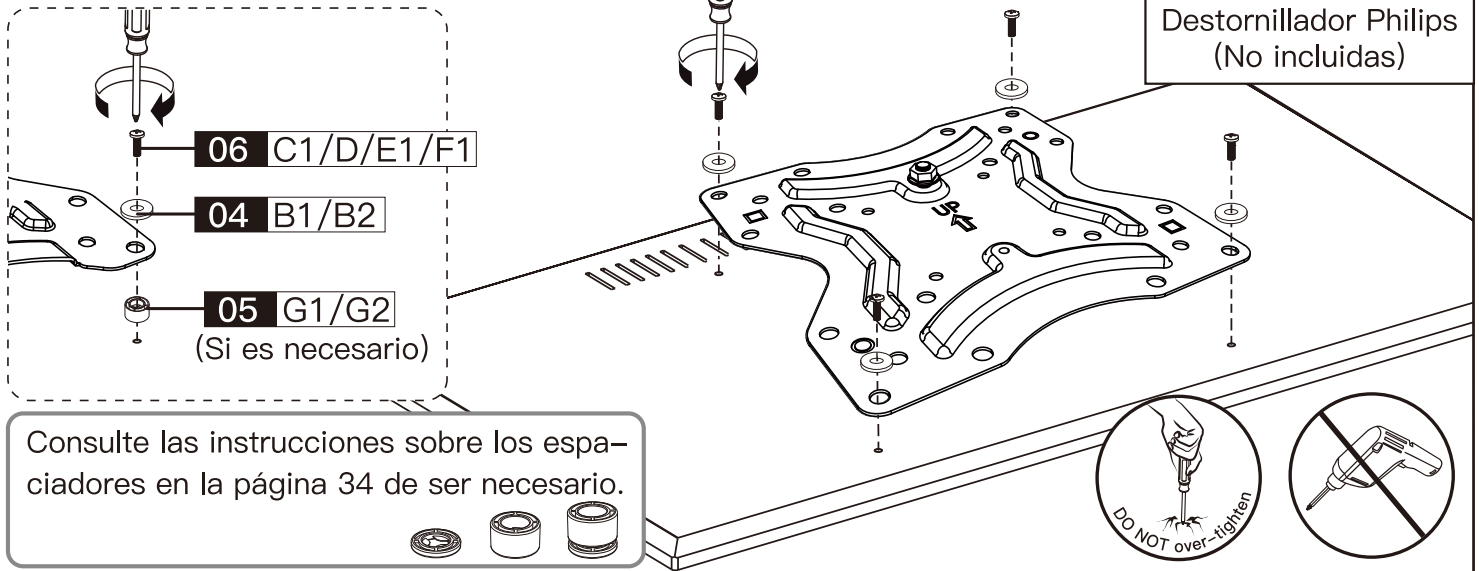

Consulte las instrucciones sobre los espaciadores en la página 34 de ser necesario.



### Opción B (para TV con respaldo curvo)

Los espaciadores deben ser lo suficientemente altos para que la curva de la parte posterior del televisor no interfiera con la placa de montaje.



Destornillador Philips  
(No incluidas)

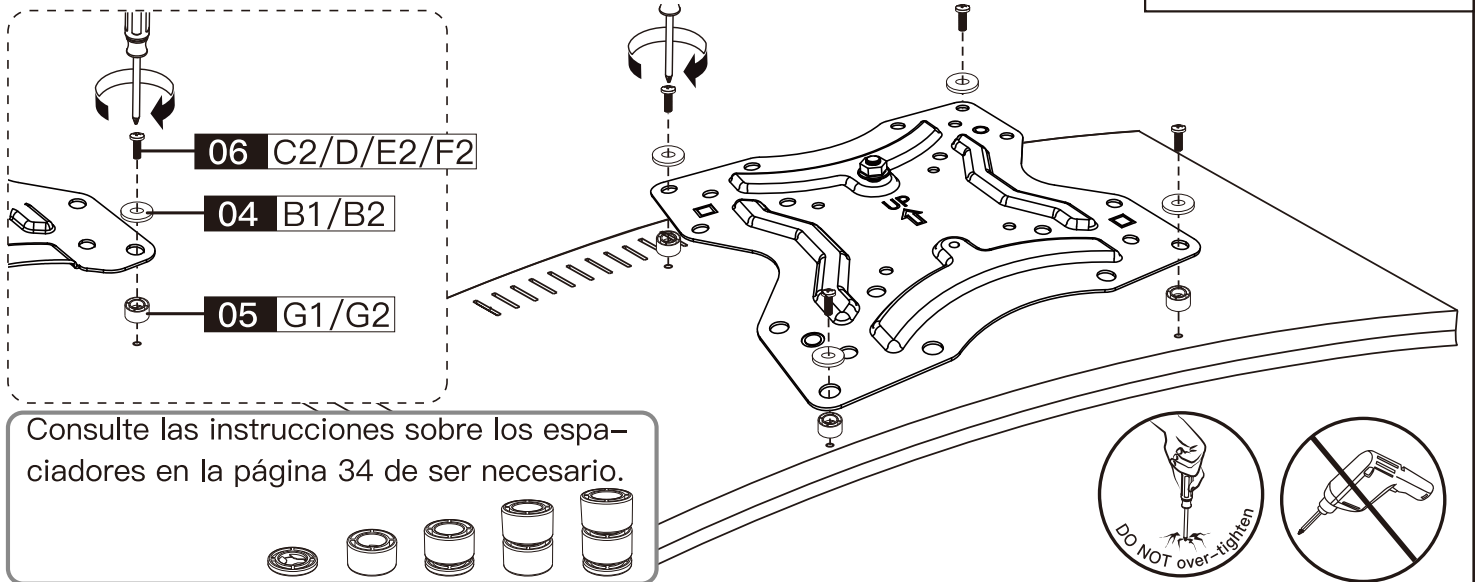

Consulte las instrucciones sobre los espaciadores en la página 34 de ser necesario.



### Opción C (Para televisores con parte trasera saliente)

Los espaciadores deben estar lo suficientemente altos para que no haya espacios entre el Soporte para TV y el bulto en la parte posterior del Televisor.

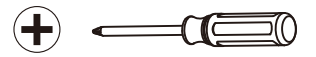

Destornillador Philips  
(No incluidas)

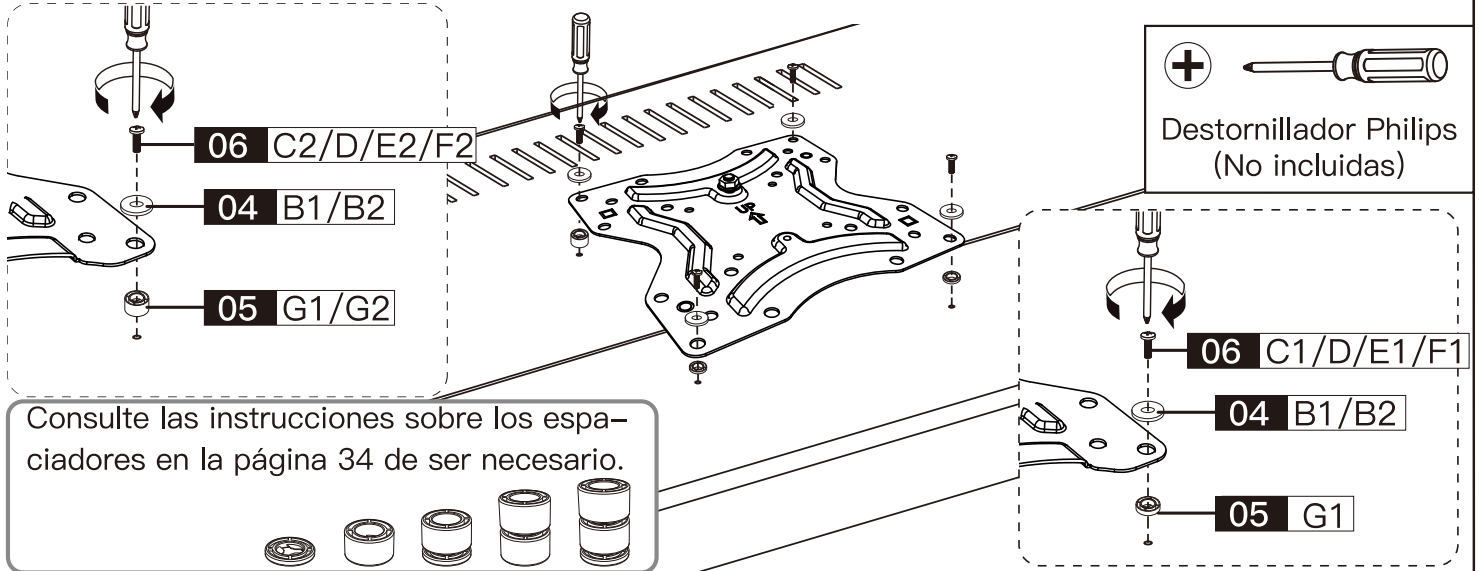

Consulte las instrucciones sobre los espaciadores en la página 34 de ser necesario.



## Opción D

### (para televisor con interferencia de cables)

Para la interferencia de cables, utilice los espaciadores [G1] y [G2] para crear un espacio extra entre el televisor y los soportes para TV.

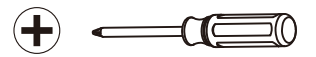

Destornillador Philips  
(No incluidas)

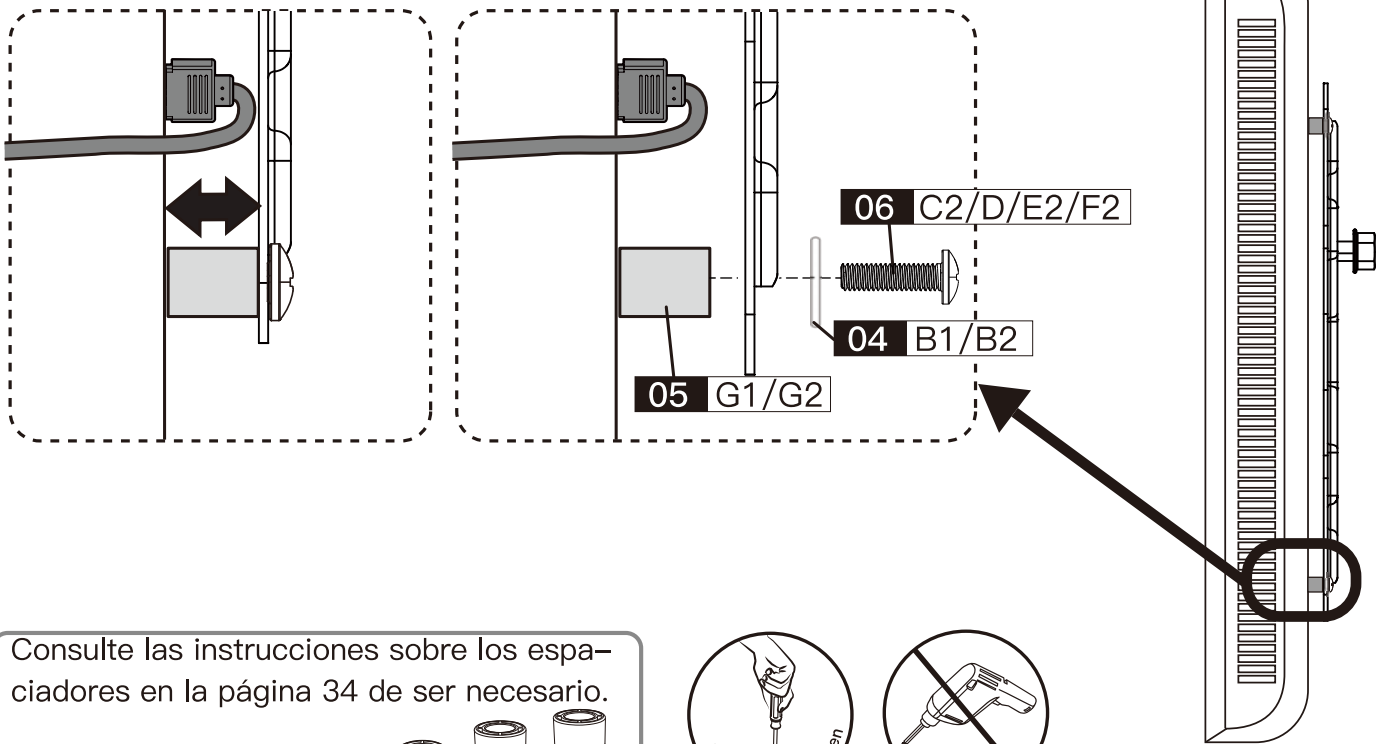

Consulte las instrucciones sobre los espaciadores en la página 34 de ser necesario.



## Opción E (Para agujeros empotrados)

El espaciador debe rellenar los agujeros empotrados en la base del televisor para que los soportes para TV estén lo más cerca posible del mismo.

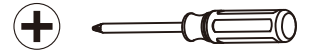

Destornillador Philips  
(No incluidas)

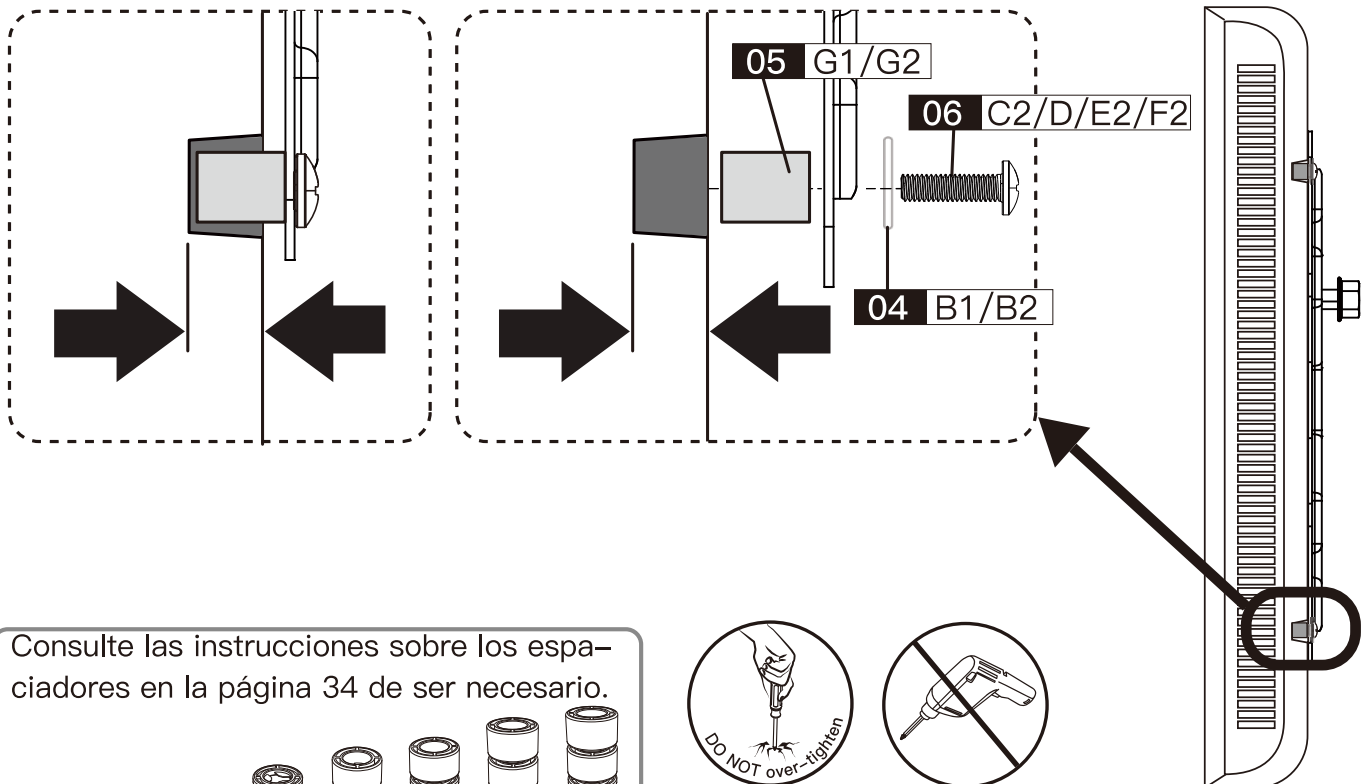

Consulte las instrucciones sobre los espaciadores en la página 34 de ser necesario.

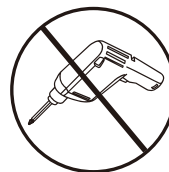

## Piezas y herrajes suministrados para el paso 3

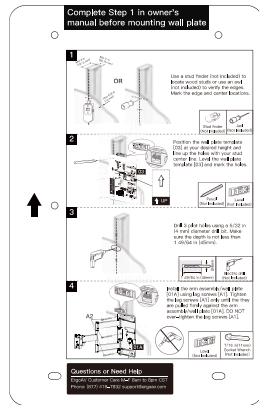

**03** x1  
Plantilla de pared

**A1** x5 Tornillo de retraso  
1/4" x 1 3/4"



**A2** x5 Anclas de  
pared  
8x40mm

**! PRECAUCIÓN!**  
Este taco es SOLO para  
paredes de hormigón. No  
los utilice en paredes de  
yeso o madera.

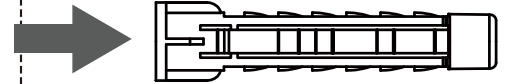

### Paso 3 Fije la placa de pared [01A] a la pared

Para la instalación en montantes de madera, siga el PASO 3A.

Para la instalación de hormigón, siga el PASO 3B.

#### Paso 3A Opción para montantes de madera

##### **! ADVERTENCIA:**

No utilice un taladro para ajustar los tornillos de retraso. Utilice únicamente una llave de tubo.

##### **! PRECAUCIÓN:**

Si lo debe instalar en una caravana, antes de taladrar, asegúrese de que el grosor de su pared sea mayor a 2 pulg.

● NO UTILICE EL TACO [A2] PARA ESTE PASO.

● Asegúrese de que la placa de pared esté bien sujeta a la pared antes de continuar con el siguiente paso.

● Tamaño nominal del montante de madera: común 51 x 102 mm (2 x 4 pulg)

● Debe revisar el centro del montante.



### 3A-1

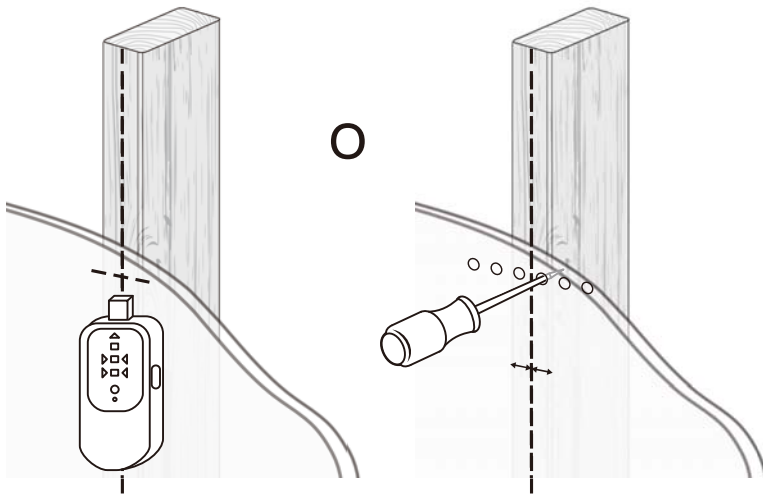

Utilice un localizador de montantes (no incluido) para localizar los montantes de madera o utilice un punzón (no incluido) para revisar los bordes. Marque los bordes y el centro.

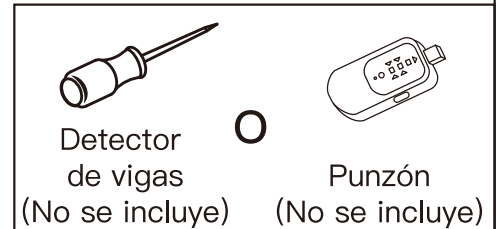

### 3A-2

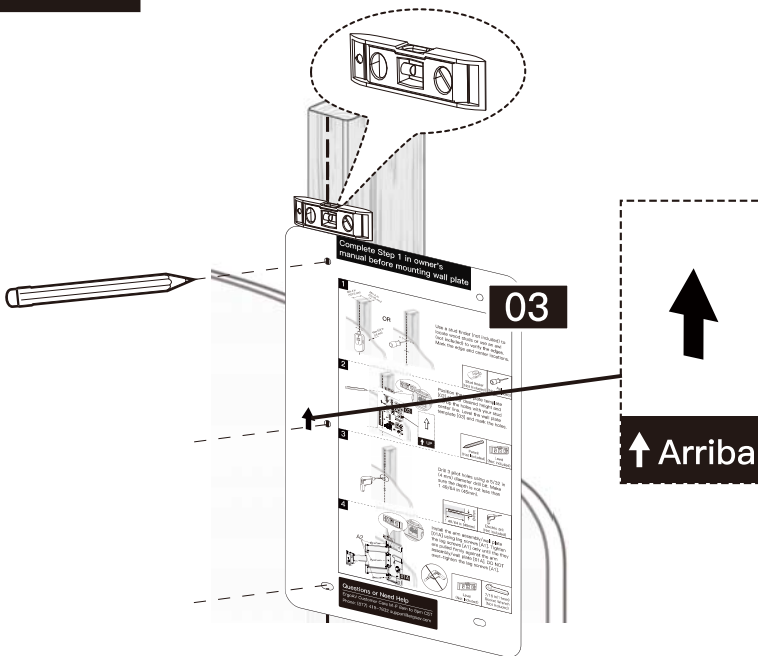

Coloque la plantilla de placa de pared [03] a la altura deseada y alinee los agujeros con la línea central de los montantes. Nivele la plantilla de placa de pared [03] y marque los agujeros.

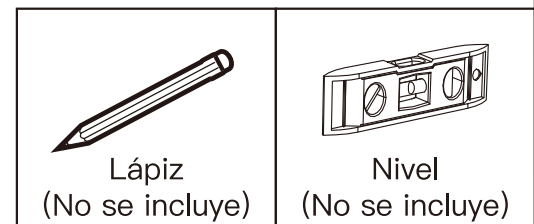

### 3A-3

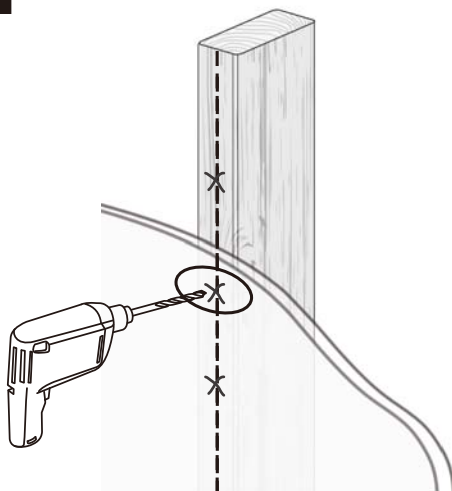

Taladre 3 los agujeros provisorios con una broca de 4 mm (5/32 pulg) de diámetro. Asegúrese de que la profundidad de los agujeros NO menor a 45 mm. (1 3/4 pulg)

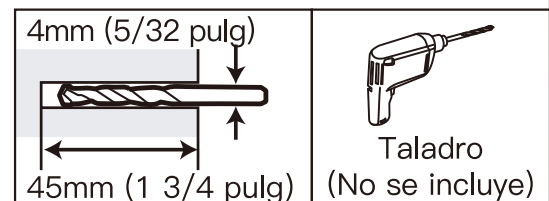



### 3A-4

**⚠ Nota:** No utilice un taladro para ajustar los tornillos de retraso. Utilice únicamente una llave de tubo.

**⚠** ¡OBJETO PESADO! Es posible que necesite asistencia en este paso.

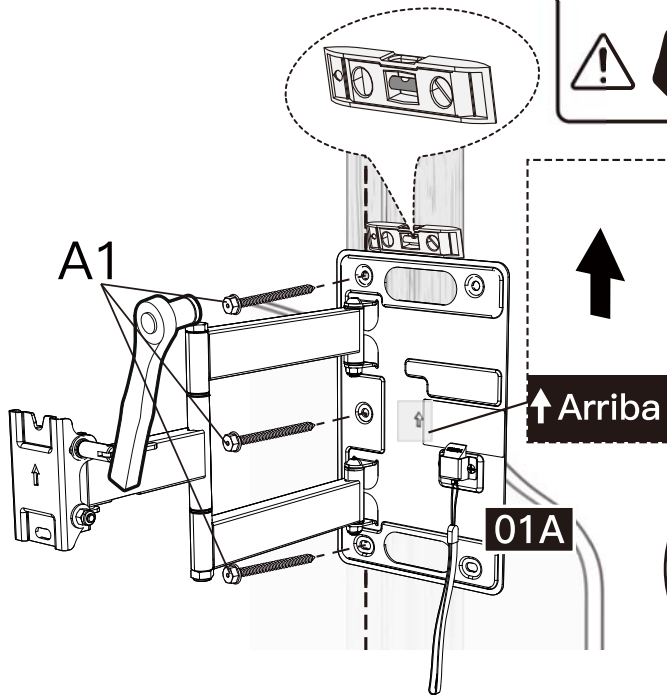

Instale la placa de pared con tornillos de retraso [A1]. Ajuste 3 los tornillos de retraso [A1] con firmeza contra la placa de pared. No ajuste demasiado los tornillos de retraso [A1].

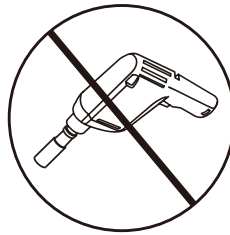

11mm (7/16 pulg)  
Llave de tubo  
(no incluidas)

### Paso 3B Opción de pared de hormigón sólido

#### **⚠ ADVERTENCIA:**

¡NO utilice un taladro para ajustar los tornillos de retraso! Utilice únicamente una llave de tubo.

● ¡Evite posibles lesiones personales o daños materiales! NO ajuste Tornillo de retraso de forma excesiva [A1]. Ajuste los tornillos de retraso [A1] solo hasta que estén bien contra la placa de pared.

● Asegúrese de que la placa de pared esté bien sujeta a la pared antes de continuar con el siguiente paso.

● Monte la placa de pared directamente sobre la superficie de hormigón sin ningún tipo de recubrimiento.

● El grosor de la pared de hormigón debe ser mayor a 140 mm (5 1/2 pulg).



**A2**

Anclas de pared

### 3B-1

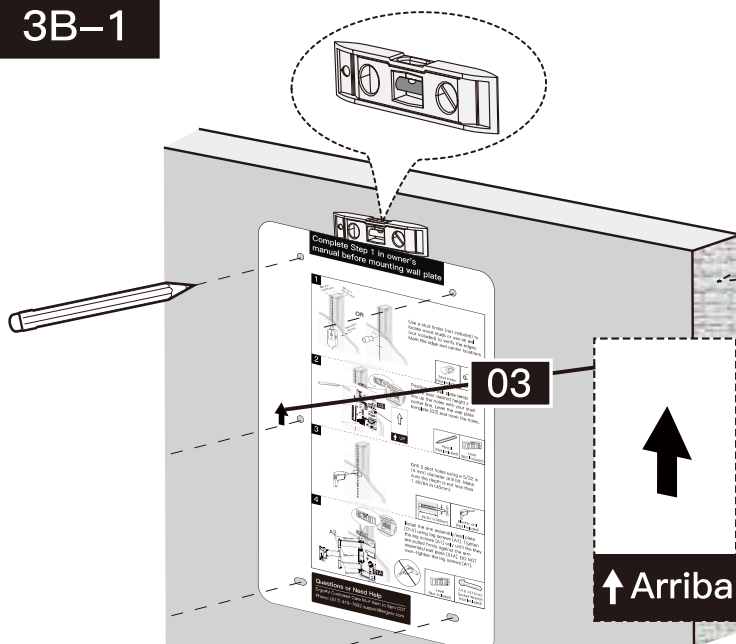

Grosor de la pared  
≥140 mm (5 1/2 pulg)

Coloque la Plantilla de Placa de Pared [03] a la altura deseada. Nivele la Plantilla de Placa de Pared [03] y marque las ubicaciones de los agujeros provisorios.

### 3B-2

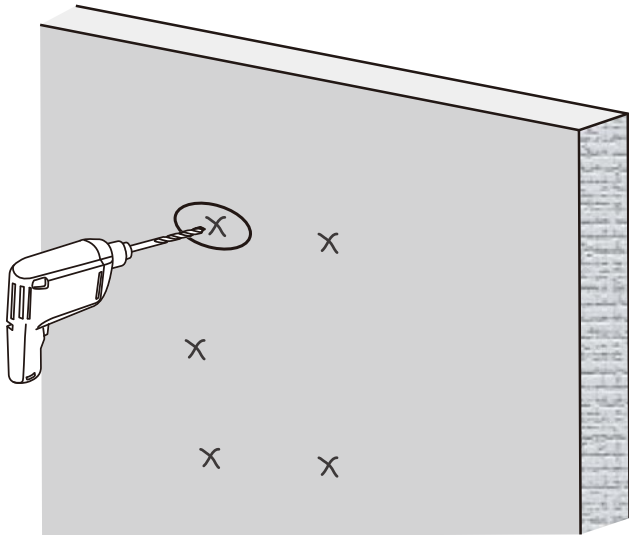

Taladre 5 agujeros piloto con una broca de 8mm (5/16 pulg) de diámetro. Asegúrese de que la profundidad no sea inferior a 50mm (2 pulg).

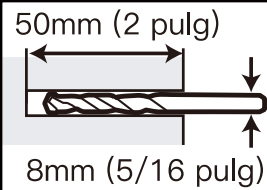

### 3B-3

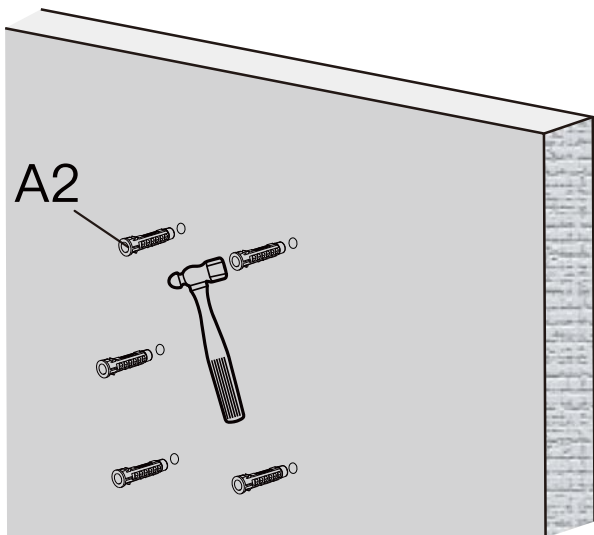

Utilice el martillo para golpear los Anclas de pared [A2] en la pared. Asegúrese de que los Anclas de pared [A2] se asienten a ras de la superficie de hormigón.

### 3B-4

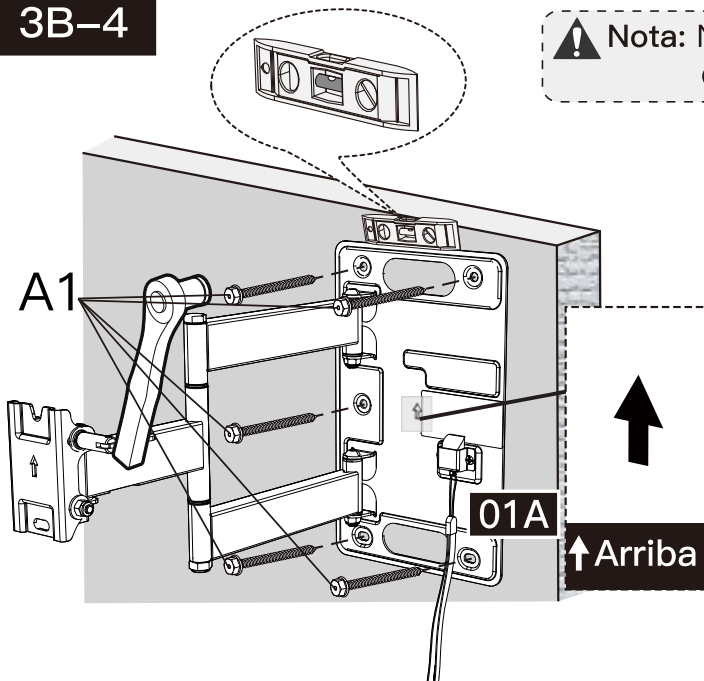

**Nota:** No utilice un taladro para ajustar los tornillos de retraso. Utilice únicamente una llave de tubo.

Use 5 tornillos de retraso [A1] para instalar el conjunto de brazo/placa de pared [01A]. Ajuste los tornillos de retraso [A1] solo hasta que estén bien contra el conjunto de brazo/placa de pared [01A]. NO ajuste Tornillo de retraso de forma excesiva [A1].

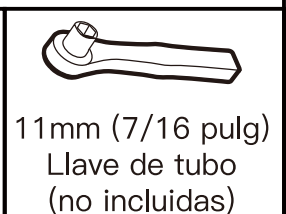

## paso 4 Cuelgue el Televisor en el Conjunto de brazo/placa de pared [01A]



¡OBJETO PESADO! Es posible que necesite asistencia en este paso.



Destornillador Philips  
(No incluidas)

**4-1** Cuelgue el Televisor en el conjunto de brazo/ placa de pared [01A], y asegúrese de que la tuerca ya montada [S2] cuelgue dentro del gancho del conjunto de brazo/ placa de pared [01A].

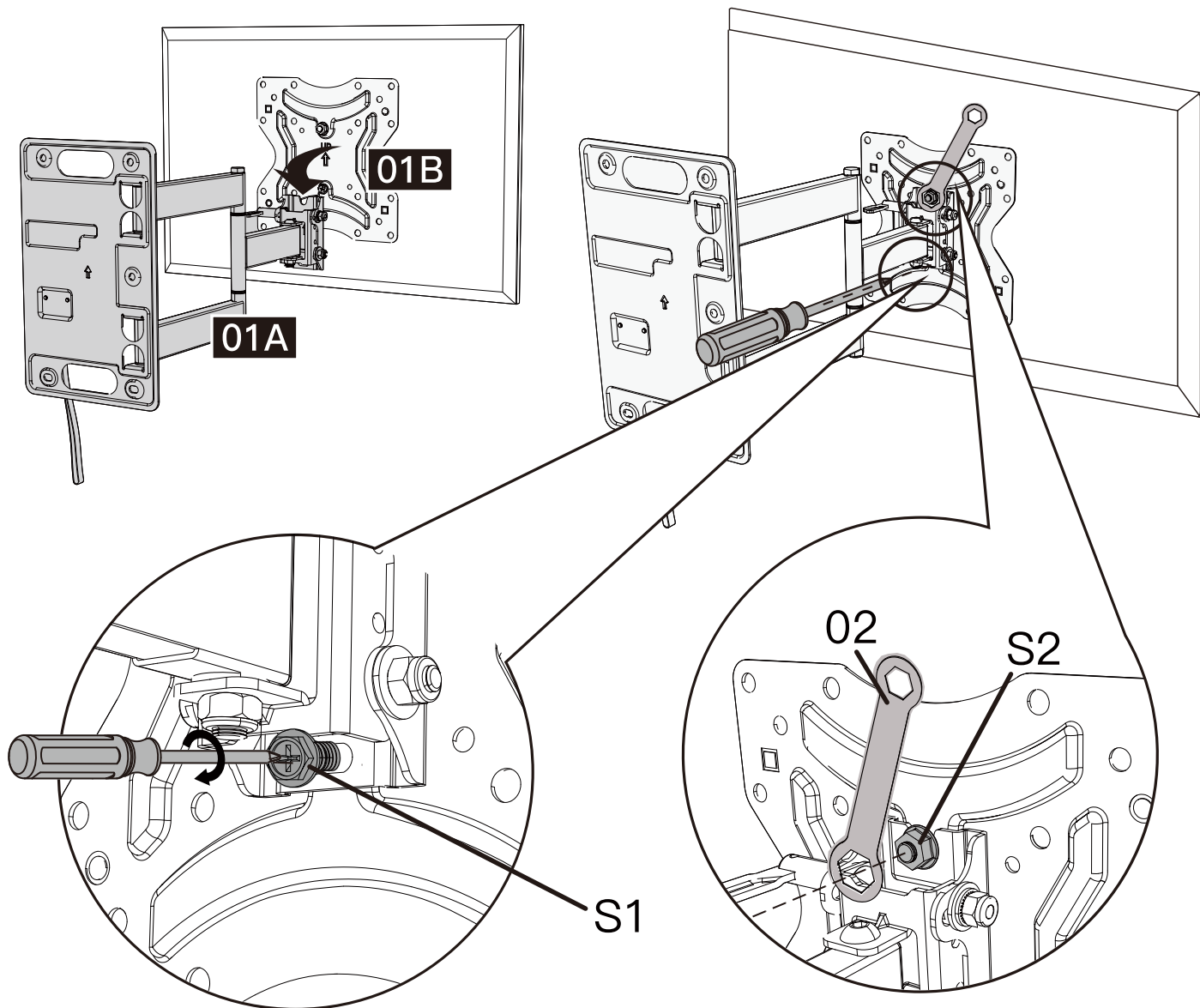

**4-2** Instale y ajuste el perno [S1] que quitó en el paso 1-3 para asegurar el Televisor al conjunto de brazo/ placa de pared [01A].

**4-3** Ajuste la tuerca [S2].

## Piezas y herrajes suministrados para el paso 5

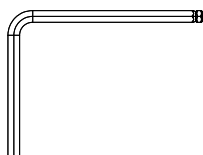

Llave Allen

**07** x1

## paso 5 Modificaciones



Ajuste de la inclinación

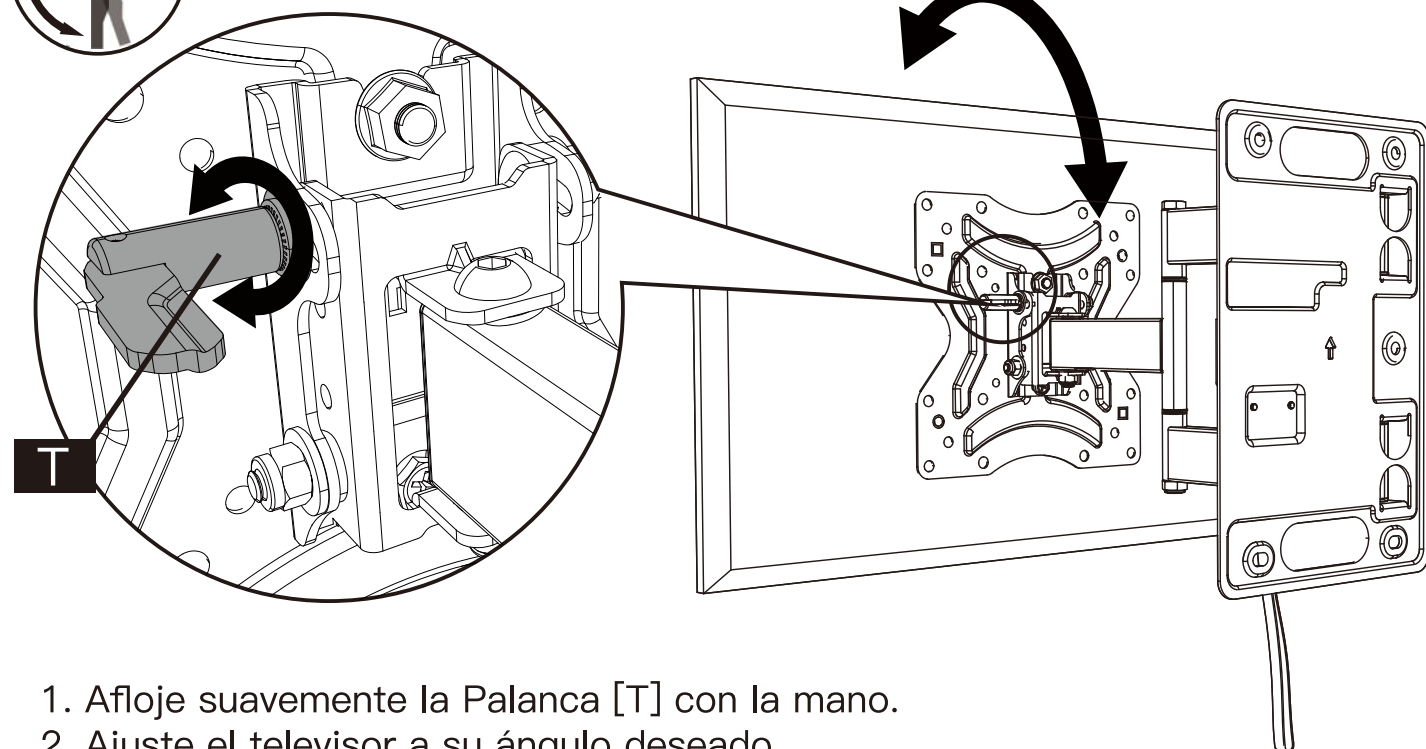

1. Afloje suavemente la Palanca [T] con la mano.
2. Ajuste el televisor a su ángulo deseado.
3. Apriete la Palanca [T] para asegurar el televisor.



Puede nivelar el Televisor de ser necesario.



Destornillador Philips  
(No incluidas)

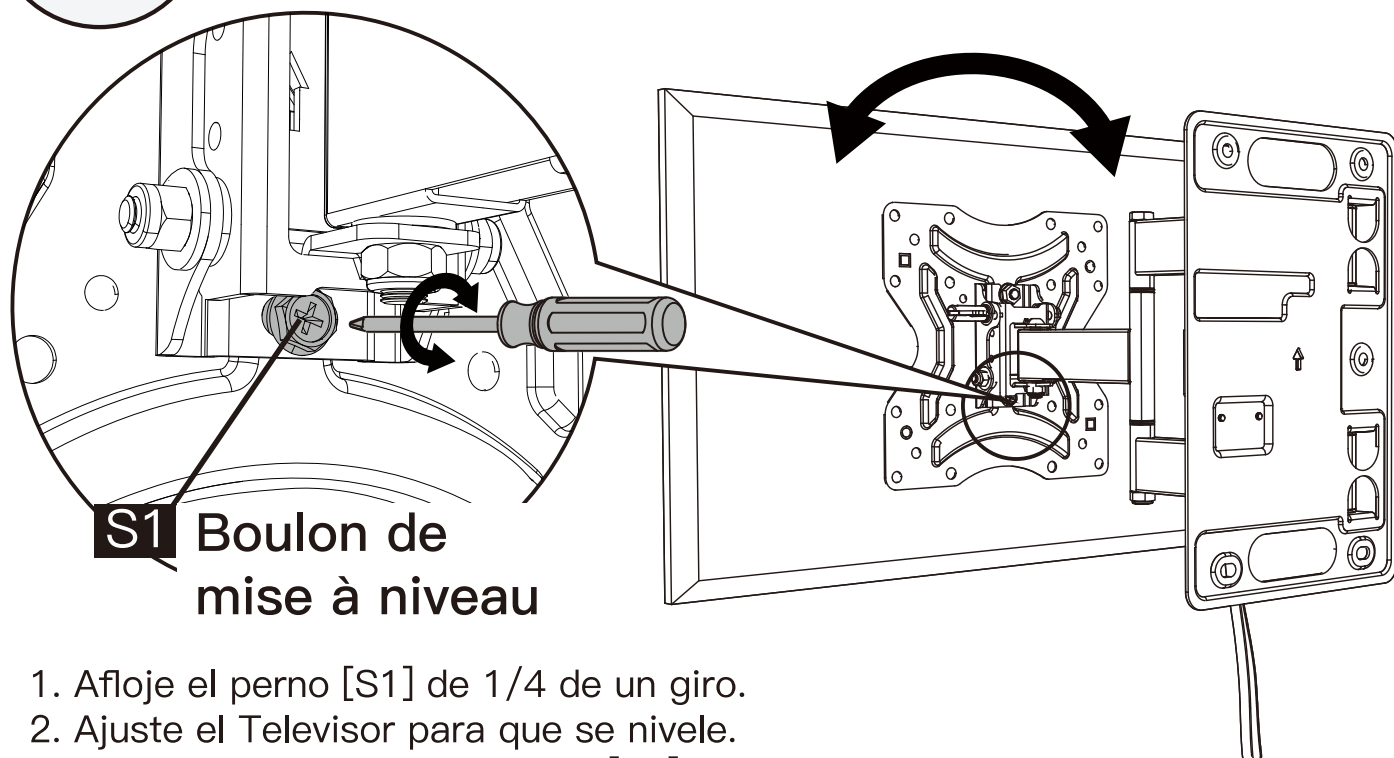

**S1** Boulon de  
mise à niveau

1. Afloje el perno [S1] de 1/4 de un giro.
2. Ajuste el Televisor para que se nivele.
3. Vuelva a ajustar bien el perno [S1].

## passo 6 Almacenamiento de su Televisor

**6-1** Para almacenar su Televisor contra la pared, empuje un poco el Televisor contra la pared mientras sostiene la correa hacia abajo. Una vez que el Televisor esté contra la pared, suelte la correa y asegúrese de que el Televisor esté sostenido en su lugar por el cerrojo.

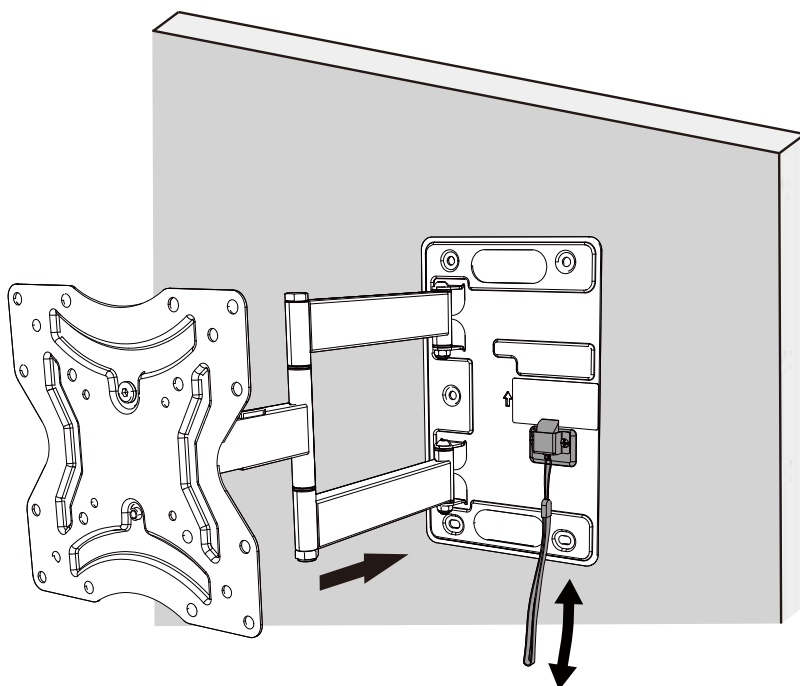

**6-2** Para sacar el Televisor desde posición de almacenamiento, empuje un poco el Televisor contra la pared y tire hacia abajo la correa. Una vez que el Televisor esté separado de la pared, suelte la correa.

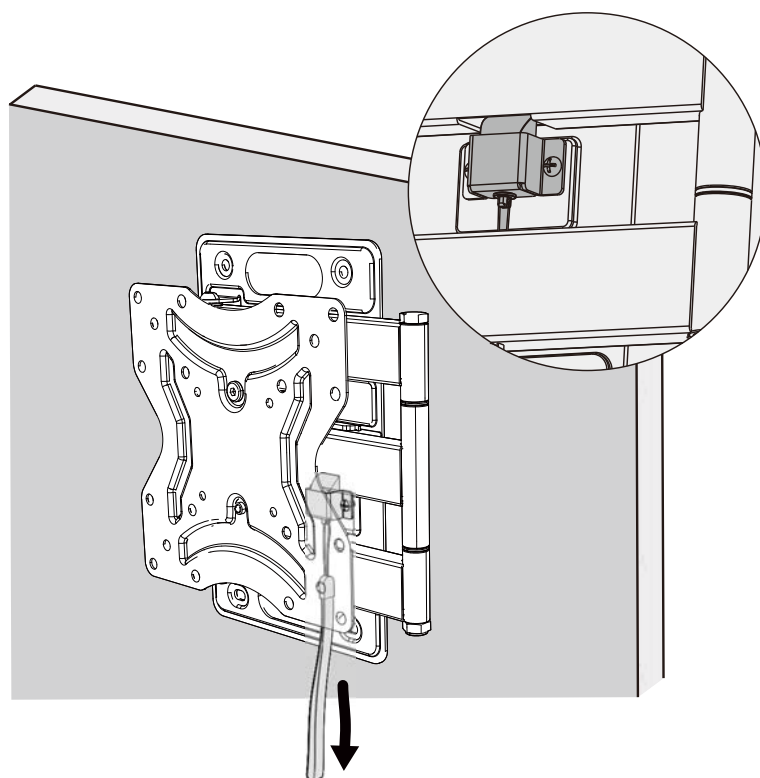





At ErgoAV, we strive to provide the highest value products.  
We want to support your purchase.  
If you have questions, concerns,  
or feedback please let us know!

ErgoAV Customer Care  
Phone (877) 419-7832  
[support@ergoav.com](mailto:support@ergoav.com)

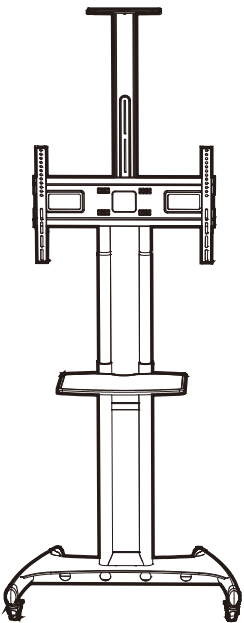

Speaker Stands

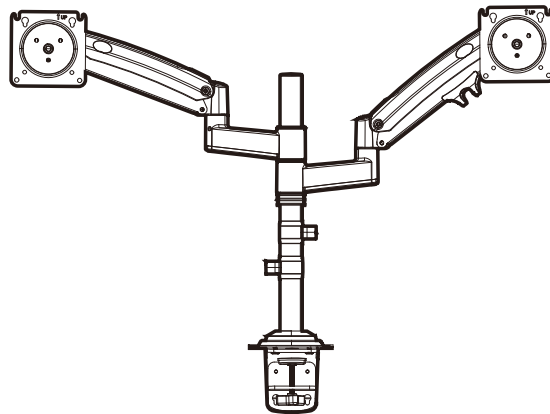

Computer Monitor Mounts

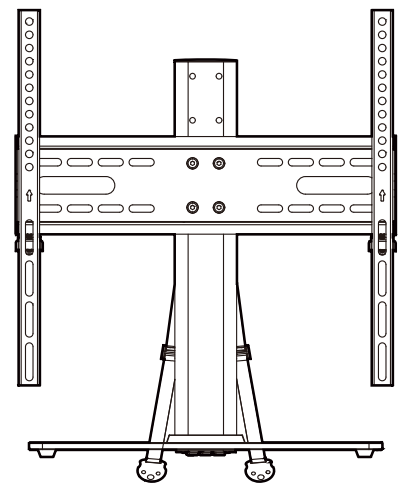

Tabletop TV Stand

9501 Louisiana Ave N, #200, Brooklyn Park, MN 55445  
[www.ergoav.com](http://www.ergoav.com)