



Motion TV Mount Instruction Manual

(A)

English pages 02–15

French pages 16–29

Spanish pages 30–43

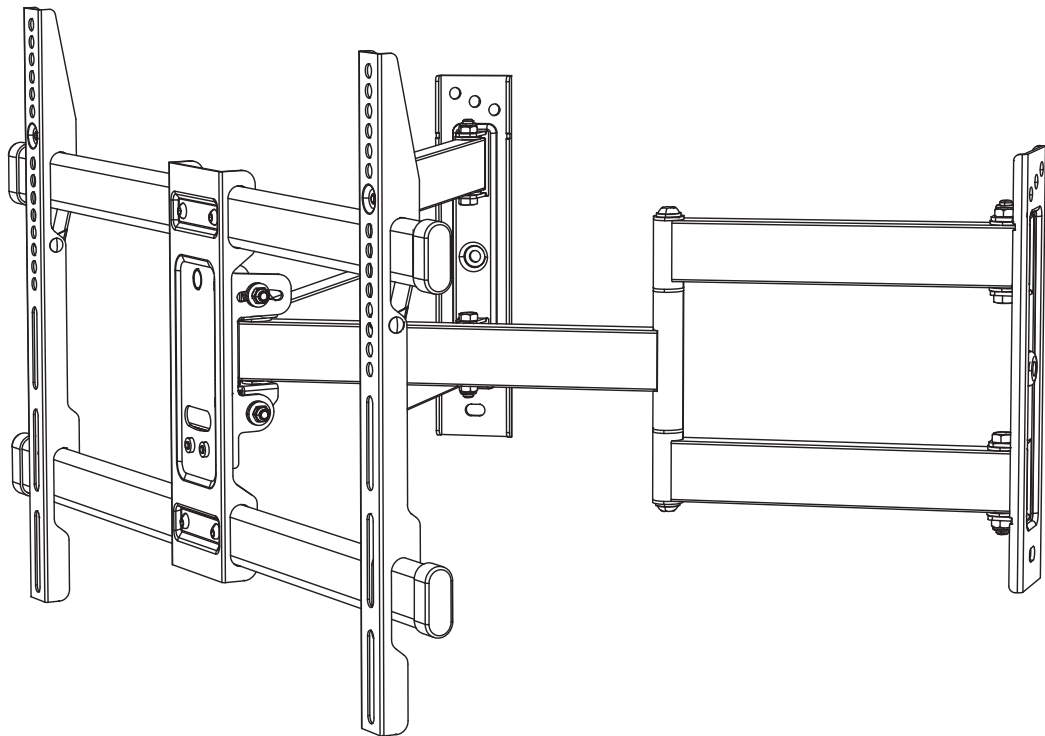

Model: ERMSL1-01B

Thank You for Choosing this ErgoAV Product!

At ErgoAV, we want to add value to your AV experience by providing the highest quality products and services in the industry. If you have any concerns or comments, please contact us.

ErgoAV Customer Care

phone (877) 419-7832

email: support@ergoav.com

website: www.ergoav.com

address: 9501 Louisiana Ave N, #200, Brooklyn Park, MN 55445

IMPORTANT SAFETY INFORMATION

⚠ DANGER! Please carefully read all instructions before attempting installation. If you do not understand the instructions or have any concerns, please contact Technical Support at (877) 419-7832 or Customer Service at support@ergoav.com.

⚠ CAUTION: Use with products heavier than the maximum weights indicated may result in instability causing possible injury.

- Do not use this product for any purpose that is not explicitly specified in this manual. Do not exceed weight capacity. We are not liable for damage or injury caused by improper mounting, incorrect assembly or inappropriate use.
- This product is designed for use in wood stud, and solid concrete walls. – DO NOT install into drywall alone.
- The wall must be capable of supporting four times the weight of the TV and mount combined.
- Use this mounting system only for its intended use as described in these instructions. Do not use attachments not recommended by the manufacturer.
- Do not use outdoors.
- Route cords and cables properly to avoid mechanical damage.
- SAVE THESE INSTRUCTIONS.

Weight Restrictions



If your TV weighs more,
Do Not use this product.

⚠ WARNING

DO NOT exceed the maximum weight indicated. This mounting system is intended for use only within the maximum weights indicated. Use with products heavier than the maximum weights indicated may result in failure of the mount and its accessories, causing damage and or injury.

Check the VESA Pattern of Your TV before the Installation

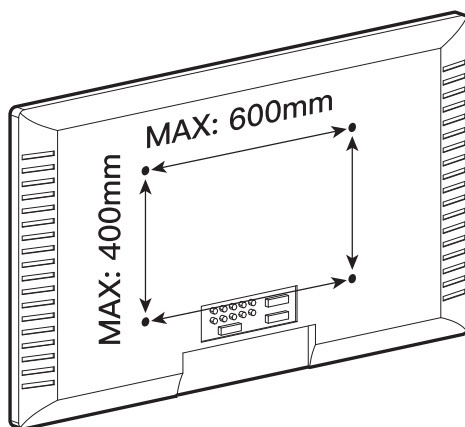

100 mm \approx 4"
200 mm \approx 7 7/8"
300 mm \approx 11 3/4"
400 mm \approx 15 3/4"
600 mm \approx 23 3/5"

Minimum: 200mm x 100mm /
8" x 4" (W x H)

Maximum: 600mm x 400mm /
24" x 16" (W x H)

If your TV's VESA Pattern is smaller than 200mm x 100mm or greater than 600mm x 400mm, this mount is NOT COMPATIBLE with your TV. Please contact Technical Support at (877) 419-7832 or support@ergoav.com to find a compatible mount.

Tools Needed (Not Included)



Stud Finder



Awl



Tape Measure

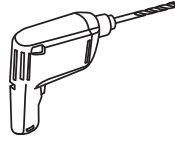

Electric drill



Pencil

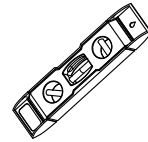

Level



Phillips
Screwdriver



7/32" (5.5mm)
Wood Drill Bit



3/8" (10mm)
Socket Wrench

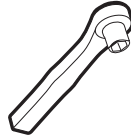

1/2" (13mm)
Socket Wrench

(Needed for concrete installs)



3/8" (10mm)
Concrete Drill Bit



Hammer

Verify Your Wall Construction

CAUTION

DO NOT
install into
drywall alone

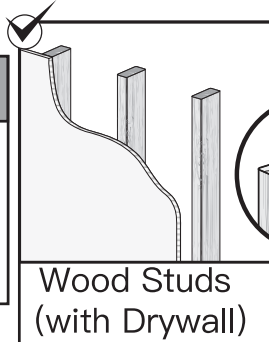

Wood Studs
(with Drywall)

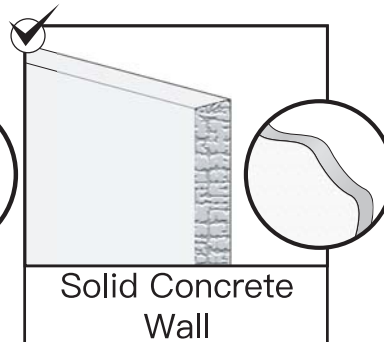

Solid Concrete
Wall

If you are not sure of
the wall construction,
please contact
Technical Support at
(877) 419-7832 or
Customer Service at
support@ergoav.com.

Supplied Parts and Hardware

WARNING: This product contains small items that could be a choking hazard if swallowed. Before starting assembly, verify all parts are included and undamaged. Do not use damaged or defective parts. If you need replacement parts, please contact Technical Support at (877) 419-7832 or Customer Service at support@ergoav.com.

• **NOTE:** Not all hardware included in this package will be used.

Supplied Parts and Hardware for Step 1

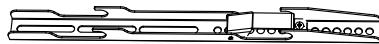

TV Bracket

01 x 2

NOTE: The washers and spacers shown are actual size.

Washers

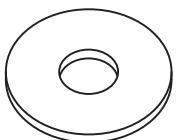

M4 / M5
[B1] x 4

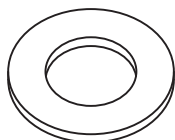

M6 / M8
[B2] x 4



L2.5mm
[F1] x 8

Spacers
[If necessary]

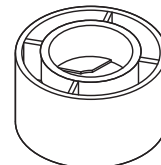

L10mm
[F2] x 4

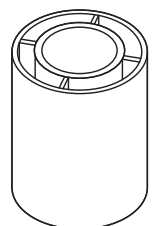

L22mm
[F3] x 4

TV Bolts (Only one size bolt fits your TV)

NOTE: The bolts shown are actual size.

M4

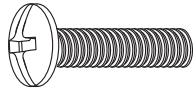

M4 x 12mm
[C1] x 4

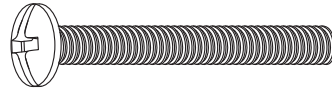

M4 x 30mm
[C2] x 4

M6

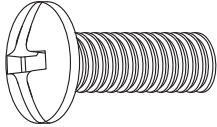

M6 x 15mm
[D1] x 4

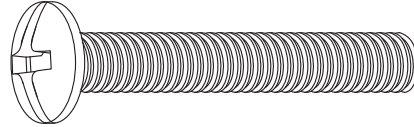

M6 x 35mm
[D2] x 4

M8

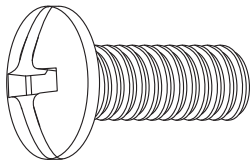

M8 x 15mm
[E1] x 4

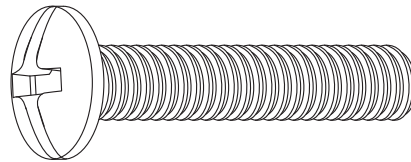

M8 x 35mm
[E2] x 4

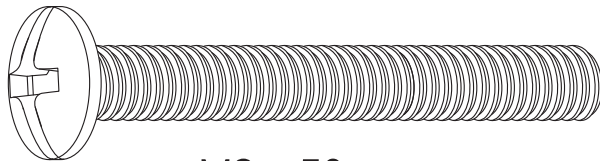

M8 x 50mm
[E3] x 4

Step 1 Secure the TV Brackets to the TV

Select TV Bolts

Only one size bolt fits your TV.

M4



M6



M8

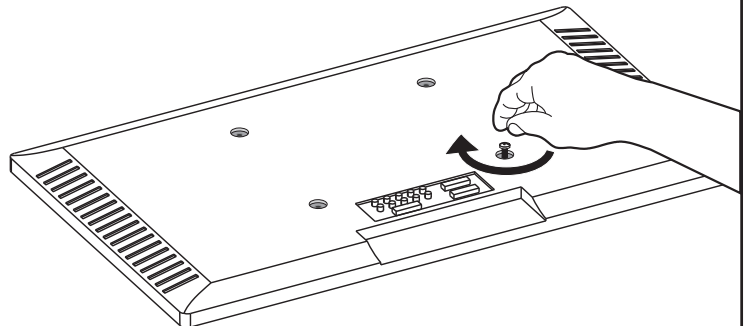

NOTE: Please do not over tighten the TV bolts to avoid damaging your TV.

Bolt length: Verify adequate thread engagement with bolts or bolts / spacers combination. We recommend thread engagement by at least 5 turns.

- Too short will not hold the TV.
- Too long will damage the TV.

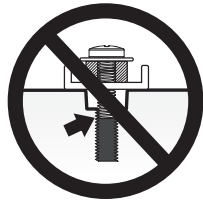

Too Short

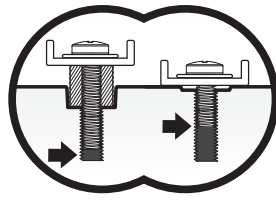

Correct



Too Long

NOTE: If spacers are required for your installation, a combination of different spacers can be stacked to obtain a proper length. See examples in the image below. If you have any difficulty understanding how to install the TV bolts or spacers, please contact Tech Support at (877) 419-7832 or Customer Service at support@ergoav.com.

Parts Needed if You Have a TV as Shown Below.

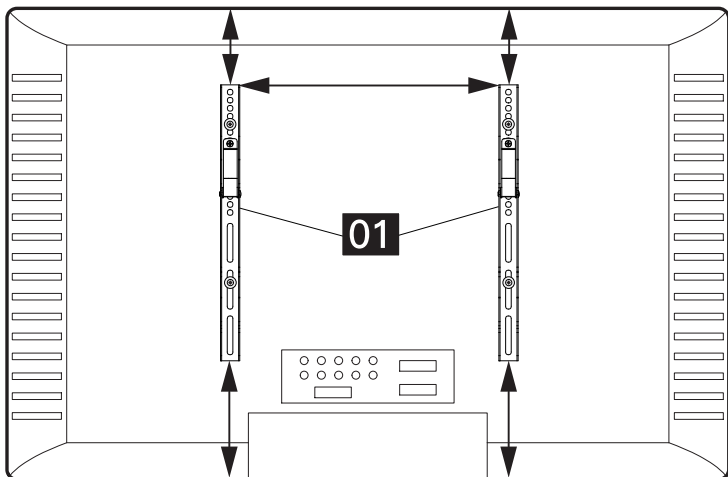
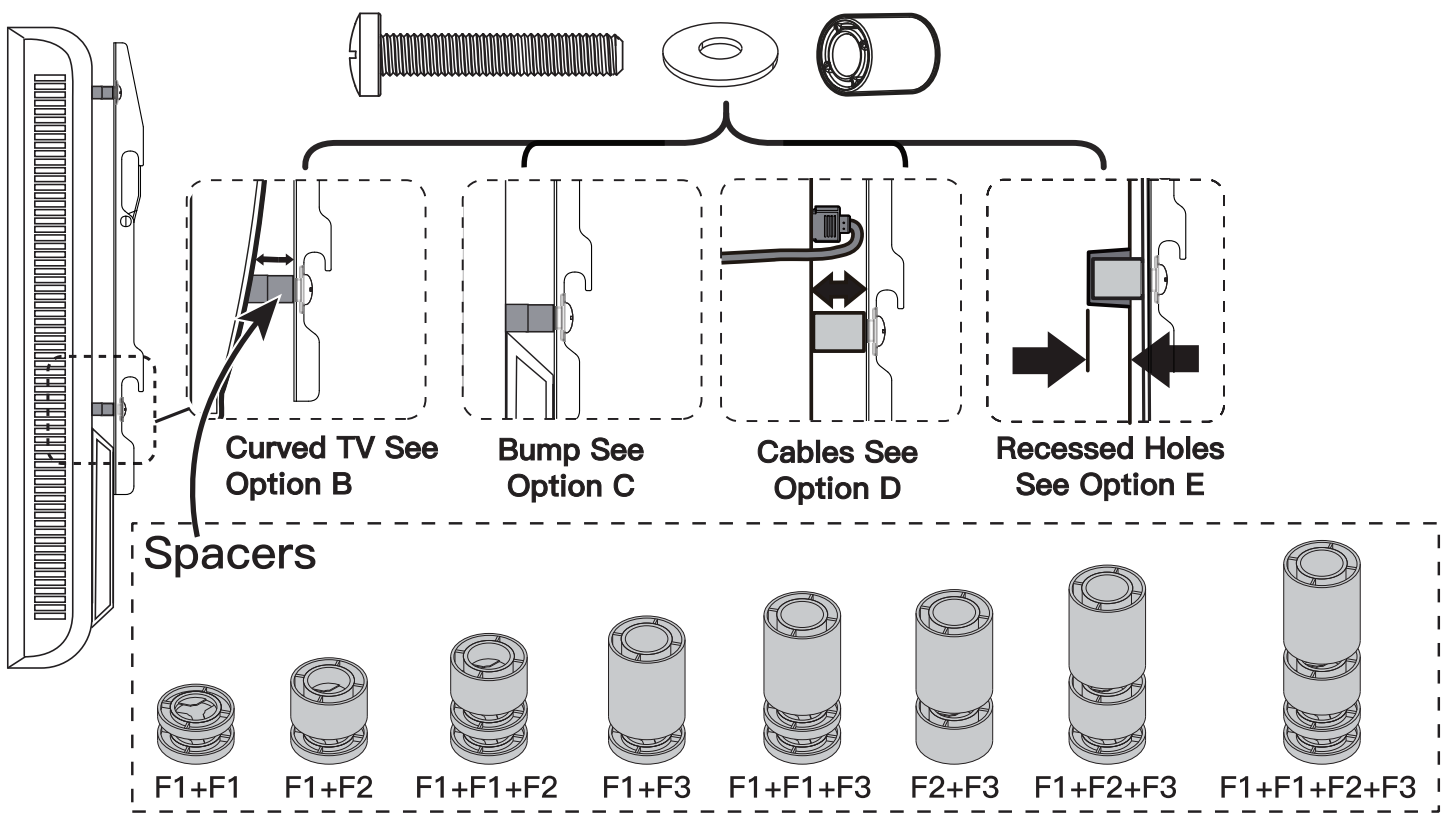

⚠ CAUTION: When attaching the TV brackets to the back of the TV, ensure the ends with the rounded holes are pointing towards the top of the TV and equally centered on the back of the TV.

⚠ NOTE: The bolt hole locations on your TV may vary in accordance of the manufacturer's design of the TV. We are only illustrating possible locations of the bolt holes.

Option A (For Flat Back TV)

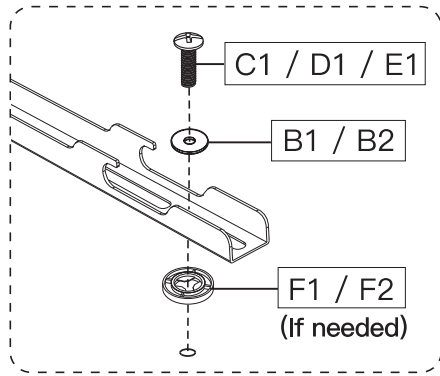

Refer back to Spacer Instructions on Page 05, If needed

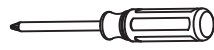
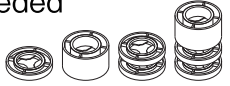

Phillips Screwdriver (Not Included)

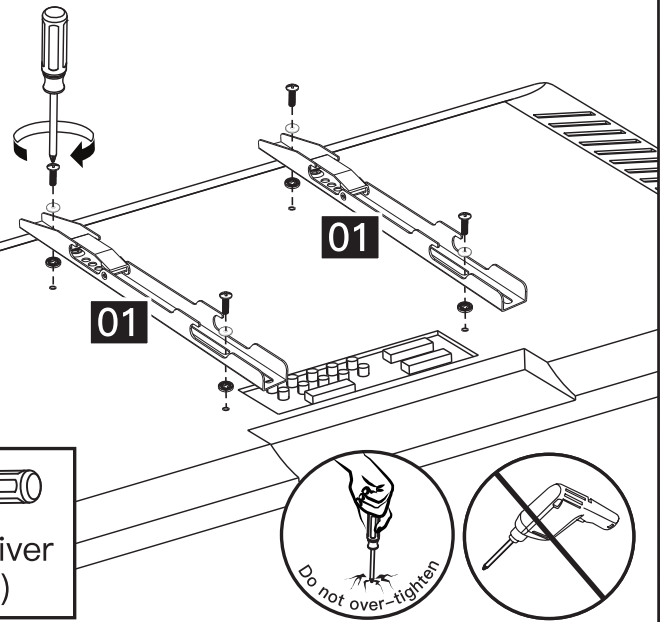

Option B (For Curved Back TV)

Spacers must be tall enough so that the curve on the back of the TV will not interfere with the mounting plate.

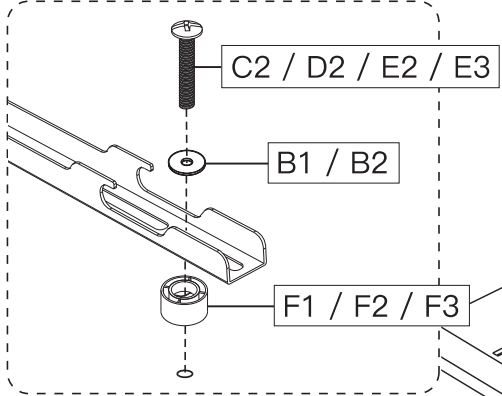

Refer back to Spacer Instructions on Page 05, If needed



Phillips Screwdriver (Not Included)

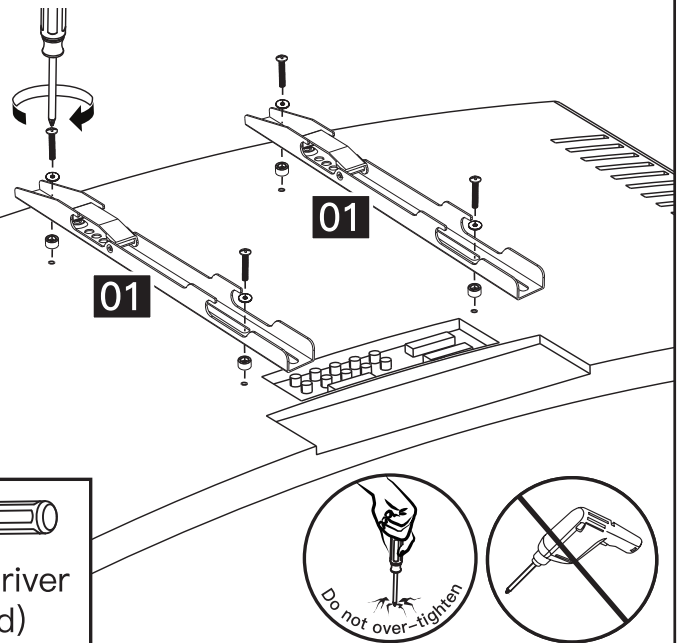

Option C (For TV with A "Bump")

Spacers must be tall enough so TV brackets are flush (NO GAP) on bump.

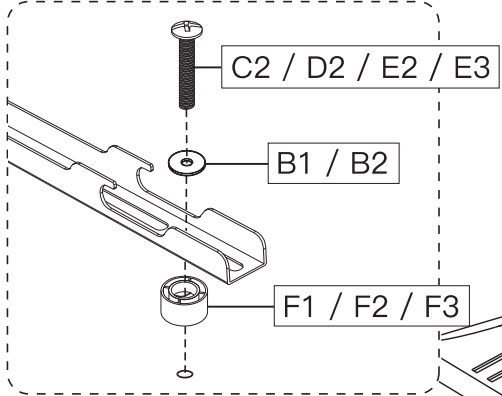

Refer back to Spacer Instructions on Page 05, If needed



Phillips Screwdriver (Not Included)

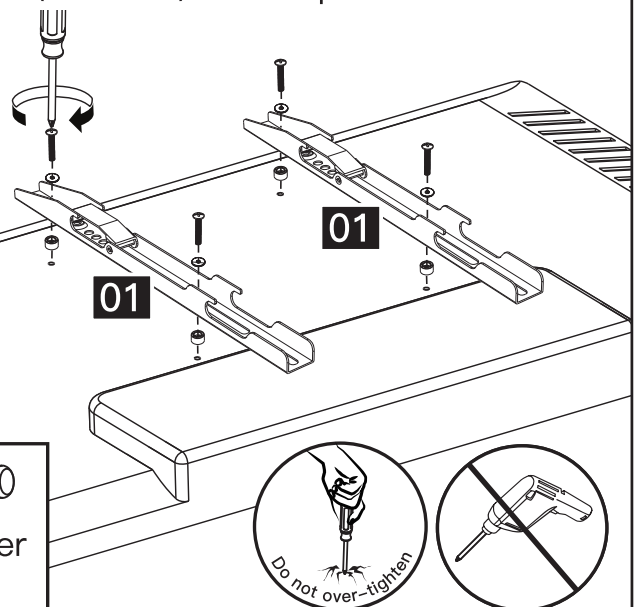

Option D (For TV with Cable Interference)

For cable interference, use spacers to create extra space between the TV and TV brackets.

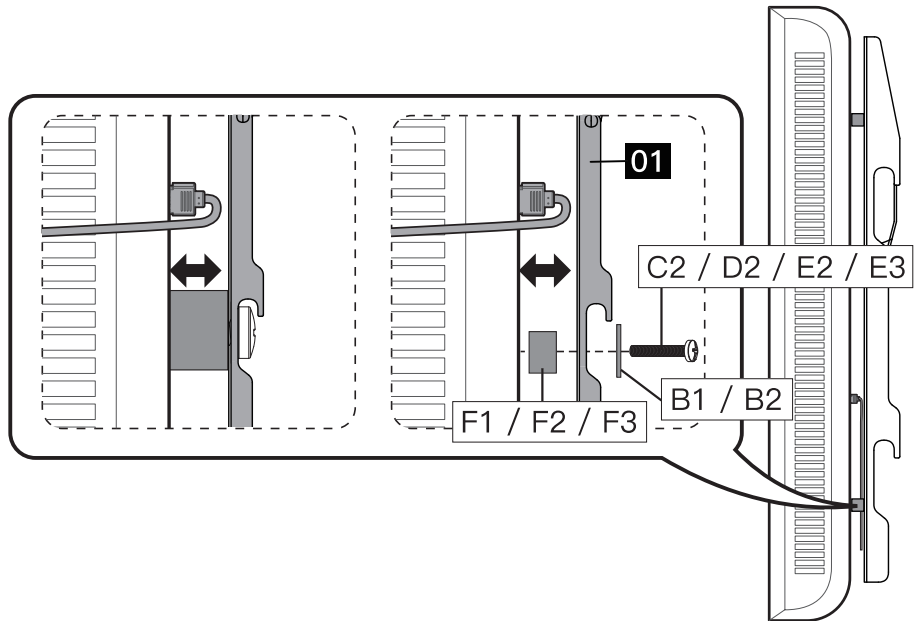
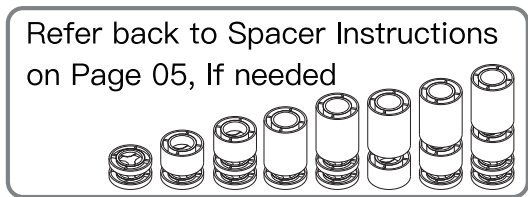
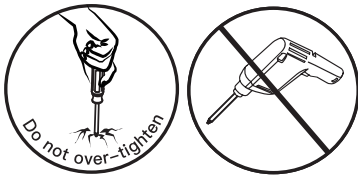

Option E (For Recessed Holes)

The spacers need to fill in the recessed holes on the back of the TV so that the TV brackets are as close to the TV as possible.

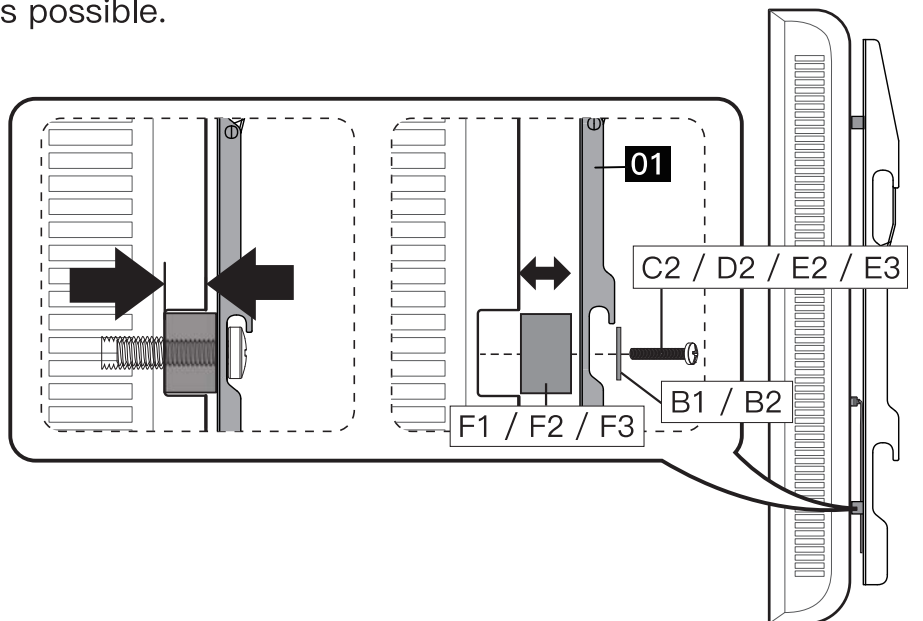
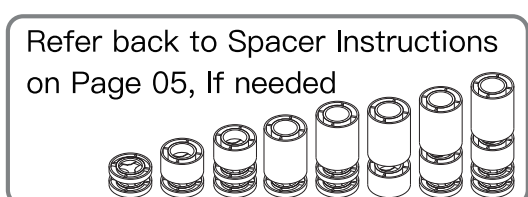
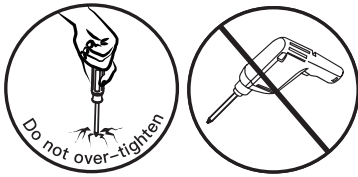

Supplied Parts and Hardware for Step 2

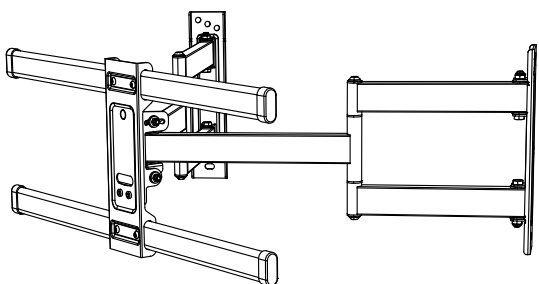

Arm Assembly / Wall Plate **02** x1

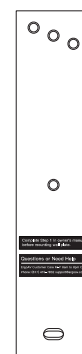

Wall Plate Template **03** x2

NOTE: The lag screw shown is actual size.

A1 x 6 Lag Screw
5/16" x 2 3/4"

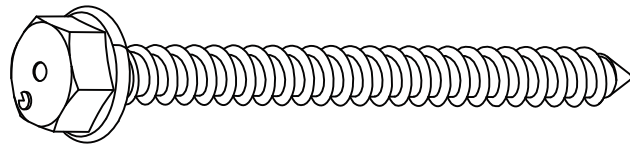

A2 x 6 Wall Anchor
10 x 60mm

! CAUTION!

This anchor is for use in concrete walls only. Do Not use them in drywall or wood studs.



Step 2 Attach the Arm Assembly / Wall Plate to the Wall

For wood stud installation, follow STEP 2A

For concrete installation, follow STEP 2B

Step 2A Wood Stud Option

!WARNING:

- To avoid potential personal injury or property damage, Do Not over-tighten the Lag Screws [A1]! Tighten the Lag Screws [A1] only until they are pulled firmly against the Wall Plate and the wall.
- Do Not use a drill when tightening the Lag Screws [A1]! Only use a socket wrench.
- **DO NOT USE THE ANCHOR [A2] FOR THIS STEP.**
- Ensure the Arm Assembly / Wall Plate [02] is securely fastened to the wall before continuing to the next step.
- Nominal wood stud size: 2" x 4" (51mm x 102mm).
- Stud center must be verified.



2A-1

NOTE: When using corner mounts, find your stud locations, mark them, and then lay the mount out on the floor. Configure it to your stud locations before installing and make sure your TV will fit the desired location.

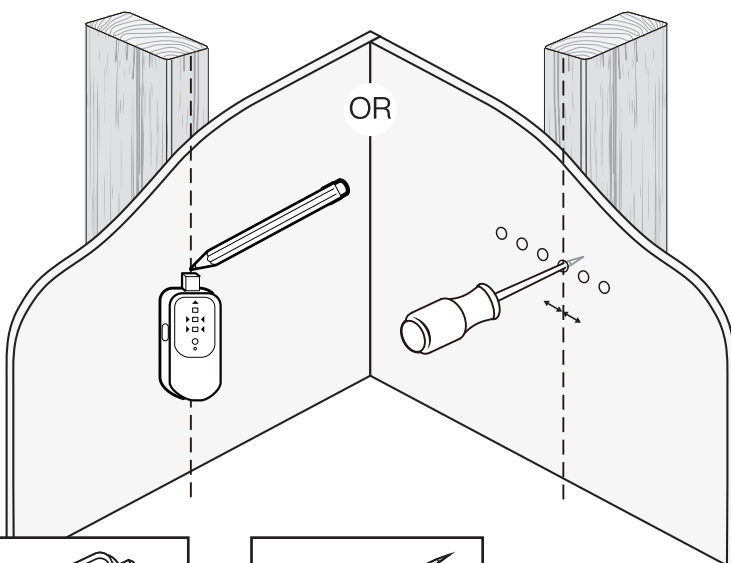

Use a stud finder to locate wood studs or use an awl to verify the edges. Mark the edge and center locations.

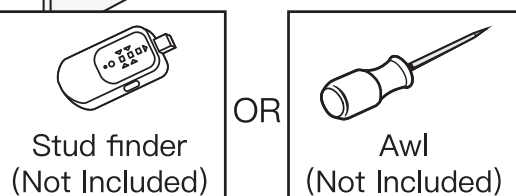
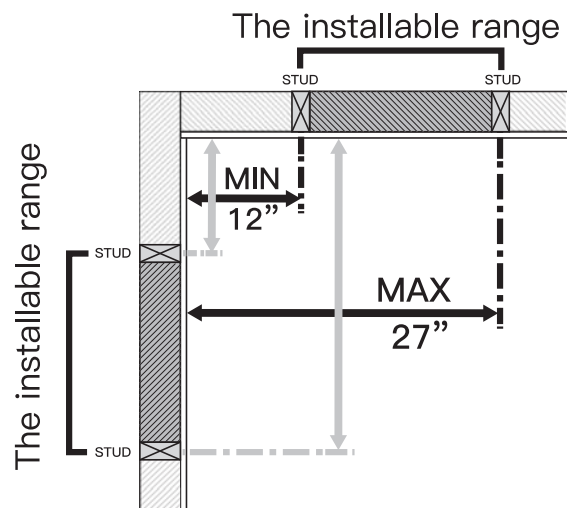

2A-2

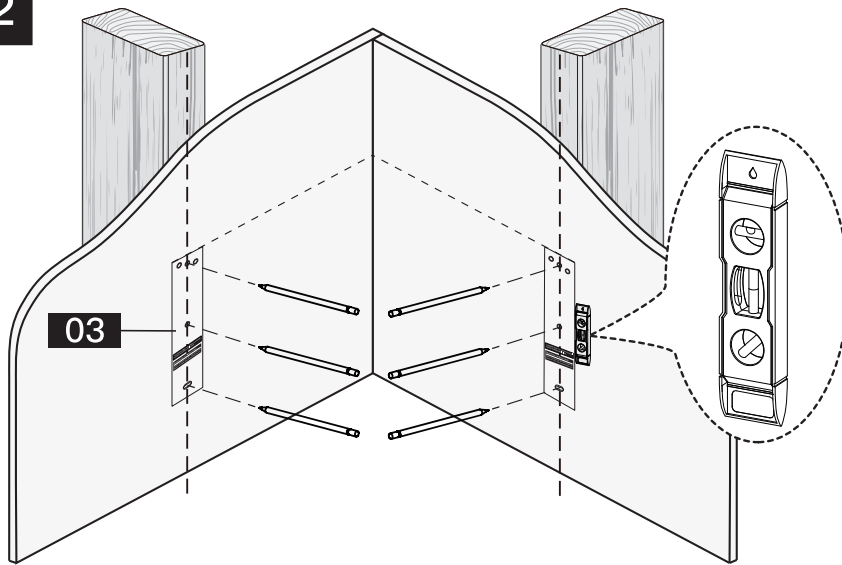

Position the Wall Plate Template [03] at your desired height and line up the holes with your stud center line. Level the Wall Plate Template [03] and mark the location for the pilot holes.

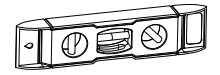

Level
(Not Included)

2A-3

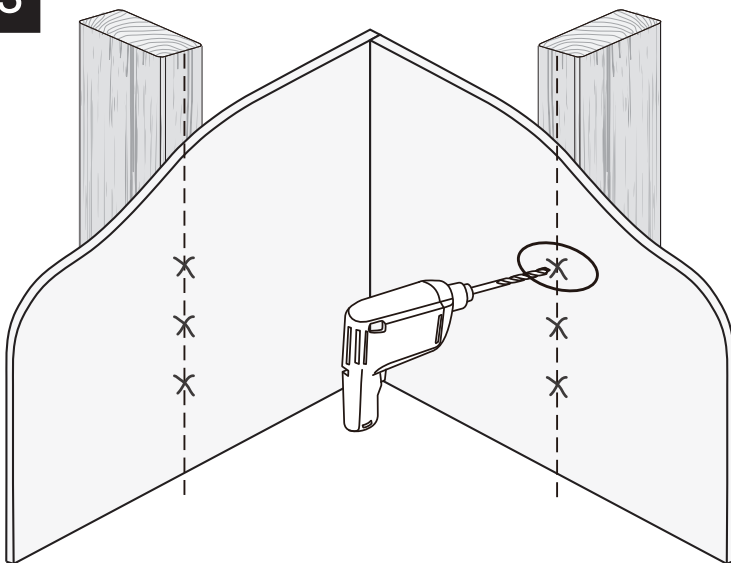

Drill the 6 pilot holes using a 7/32" (5.5mm) diameter drill bit. Make sure the depth of the pilot holes is at least 2 3/4" (70mm) deep.

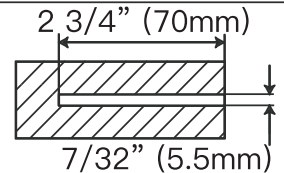

2A-4

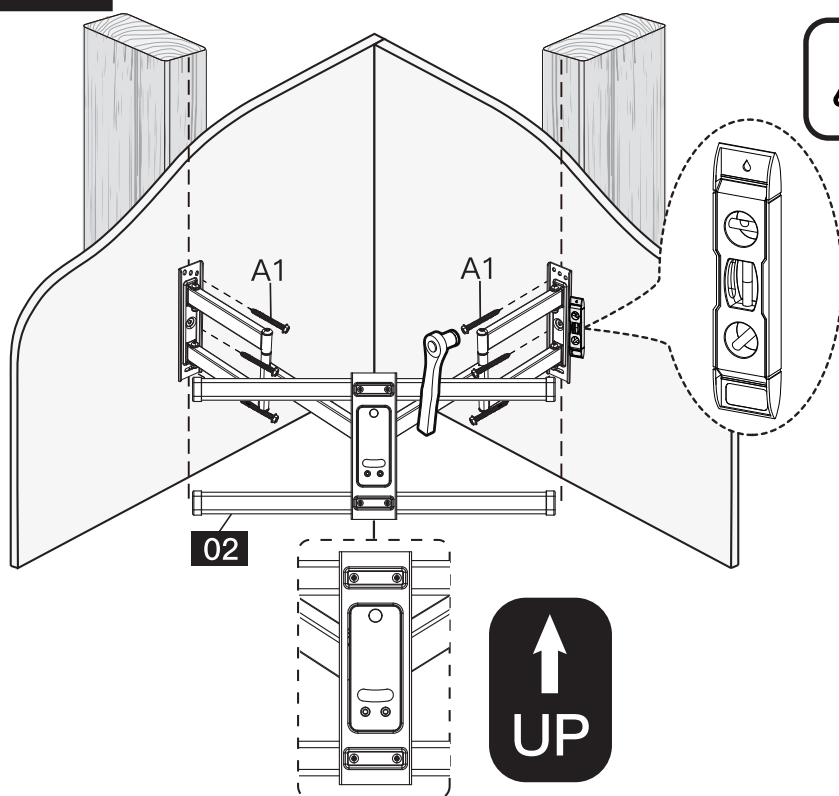

  **HEAVY!** You may need assistance with this step.

NOTE: Do not use a drill to tighten the Lag Screws [A1]. Only use a socket wrench.

Install the Arm Assembly / Wall Plate [02] using 6 Lag Screws [A1]. Tighten the Lag Screws [A1] only until they are pulled firmly against the Wall Plate and the wall.

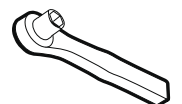
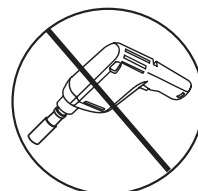

1/2" (13mm)
Socket Wrench
(Not Included)

Step 2B Solid Concrete Wall Option

⚠ WARNING:

- To avoid potential personal injury or property damage, Do Not over-tighten the Lag Screws [A1]! Tighten the Lag Screws [A1] only until they are pulled firmly against the Wall Plate and the wall.
- Do Not use a drill when tightening the Lag Screws [A1]! Only use a socket wrench.
- Ensure the Arm Assembly / Wall Plate [02] is securely fastened to the wall before continuing to the next step.
- Mount the Arm Assembly / Wall Plate [02] directly onto the concrete surface without any covering.
- The thickness of the concrete wall must exceed 5 1/2" (140mm).



Wall Anchor
A2

2B-1

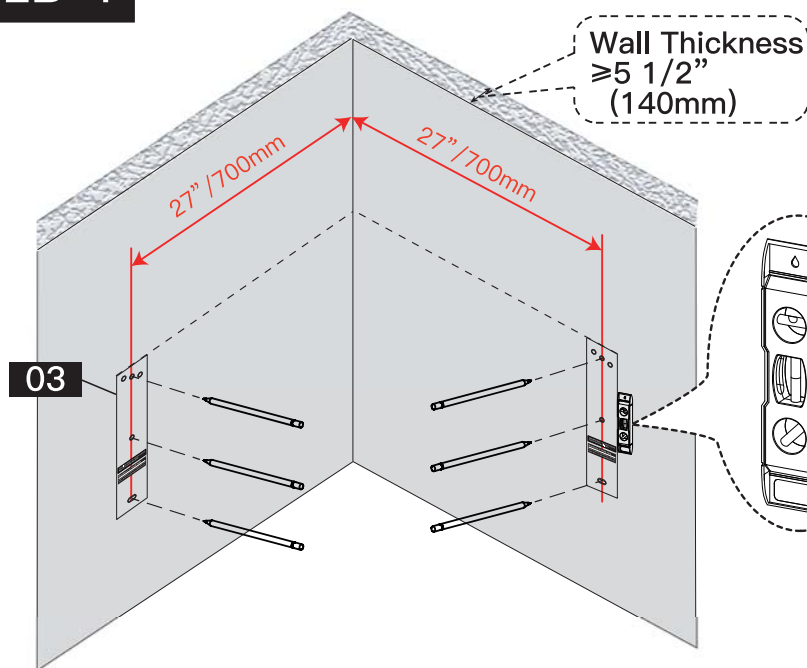

Position the Wall Plate Template [03] at your desired height. Level the Wall Plate Template [03] and mark the locations for the pilot holes. (the distance between the center location and the corner of the wall should be 27" \approx 700mm)

2B-2

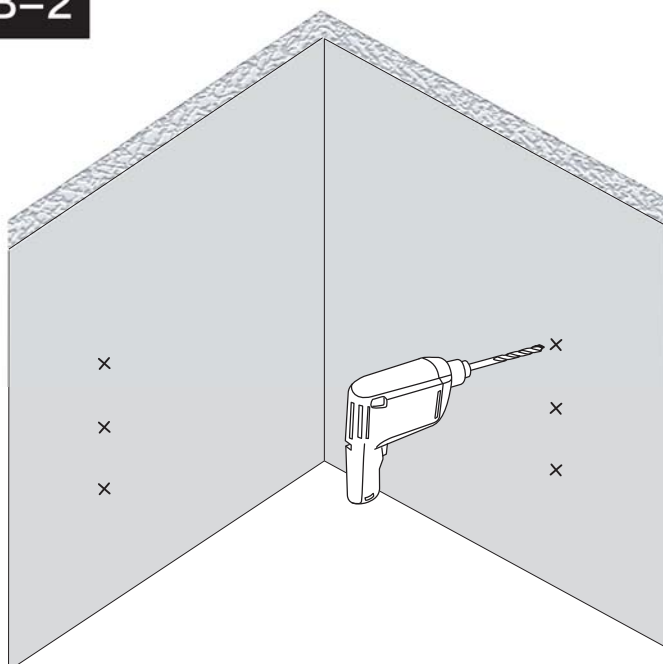

Drill the 6 pilot holes using a 3/8" (10mm) diameter concrete drill bit. Make sure the depth is at least 3" (75mm) deep.



Electric Drill
(Not Included)

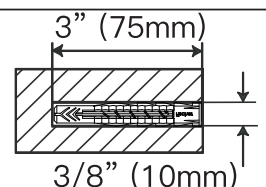

Step 3 Secure the TV with Brackets to the Front Support Assembly

3-1 Remove the Pre-Assembled Bolts [S2] from the TV Brackets [01] using a self-supplied Phillips screwdriver. Save Bolts [S2] for use in Step 3-3.

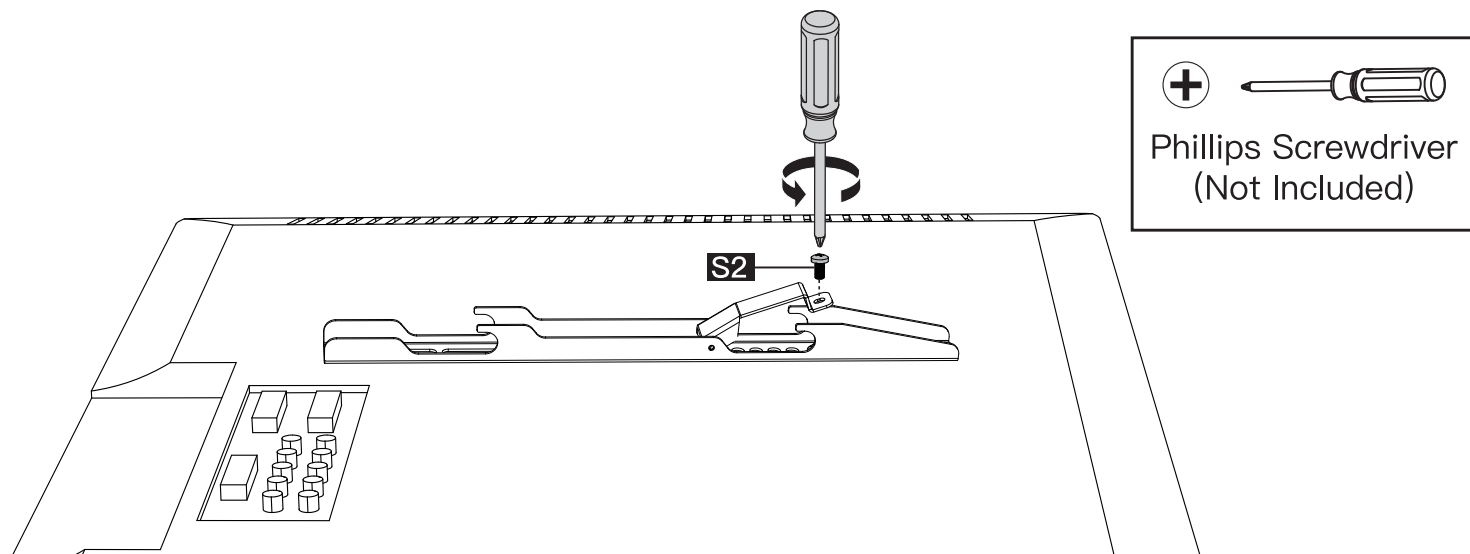

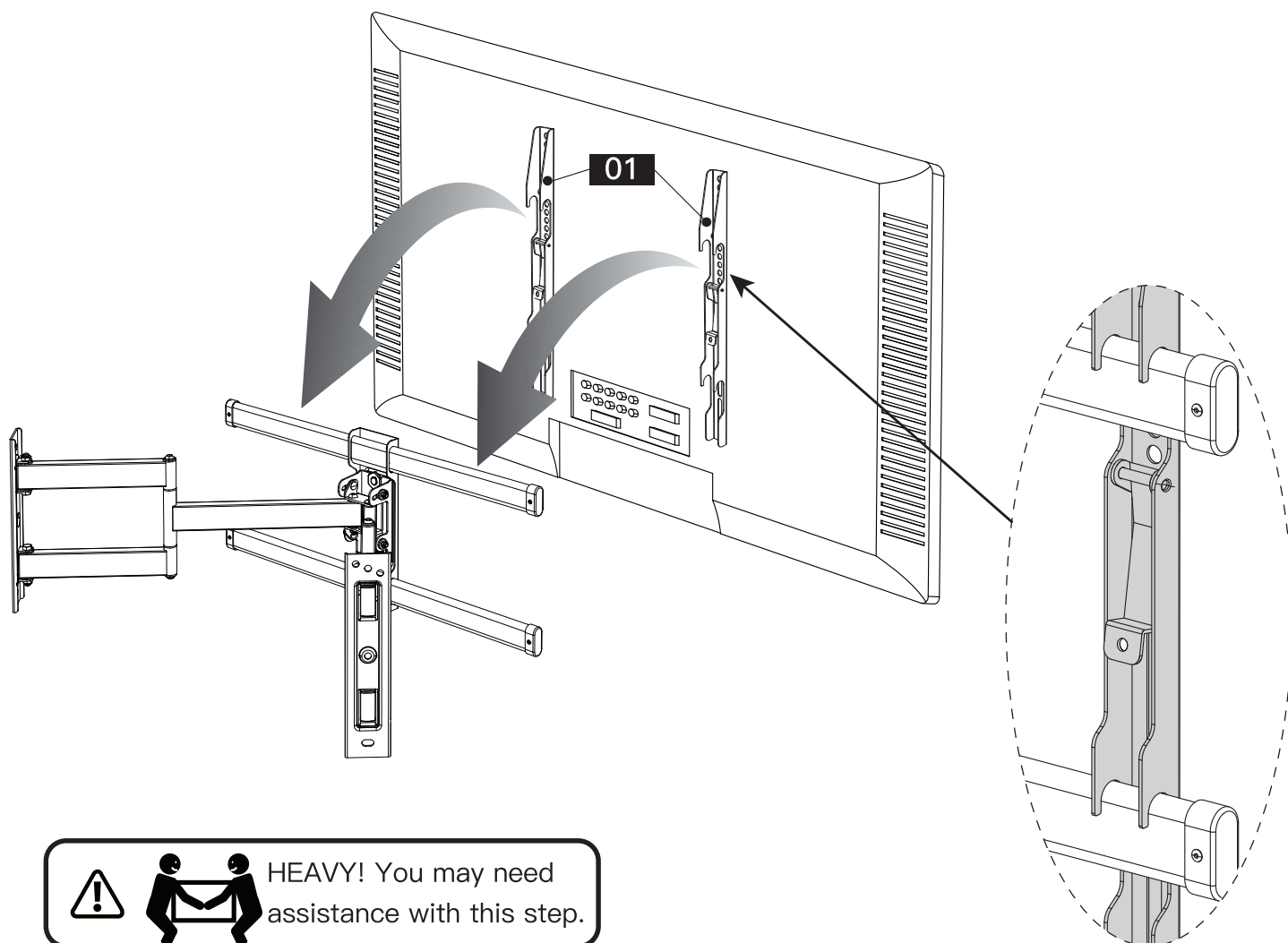

3-2 Before attempting to hang TV, make sure the Locking Tabs are positioned towards the bottom of the TV. Hang TV with TV Brackets [01] onto the Front Support. Make sure that the upper and lower hooks on the TV Brackets [01] are over the Front Support Bars.

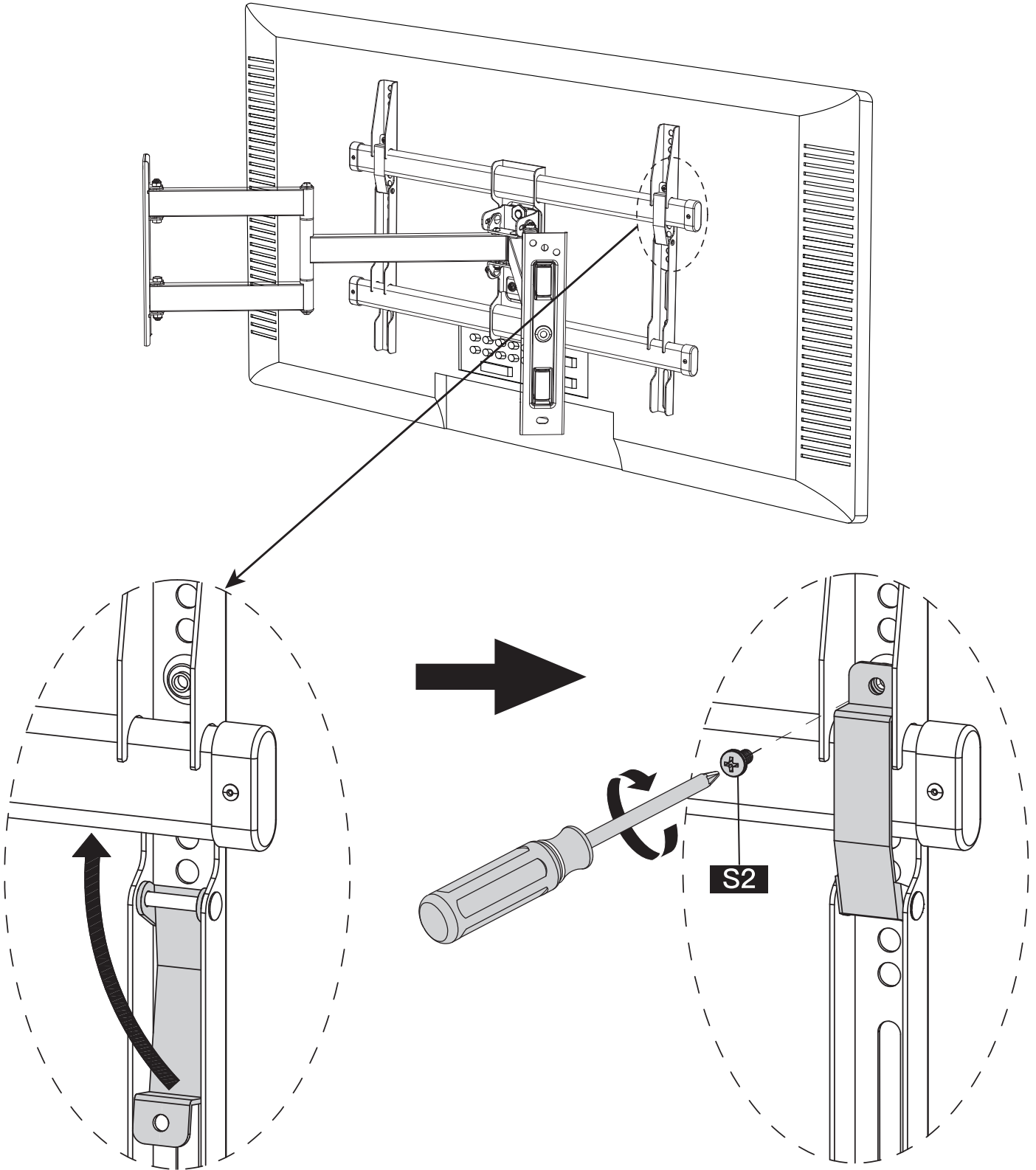

3-3 Position the Locking Tabs towards the top of the TV and secure the Locking Tabs in place using Bolts [S2] from Step 3-1. Firmly tighten Bolts [S2].



  **HEAVY!** You may need assistance with this step.

 **Phillips Screwdriver**
(Not Included)

Step 4 Adjustments

Tilt Adjustment

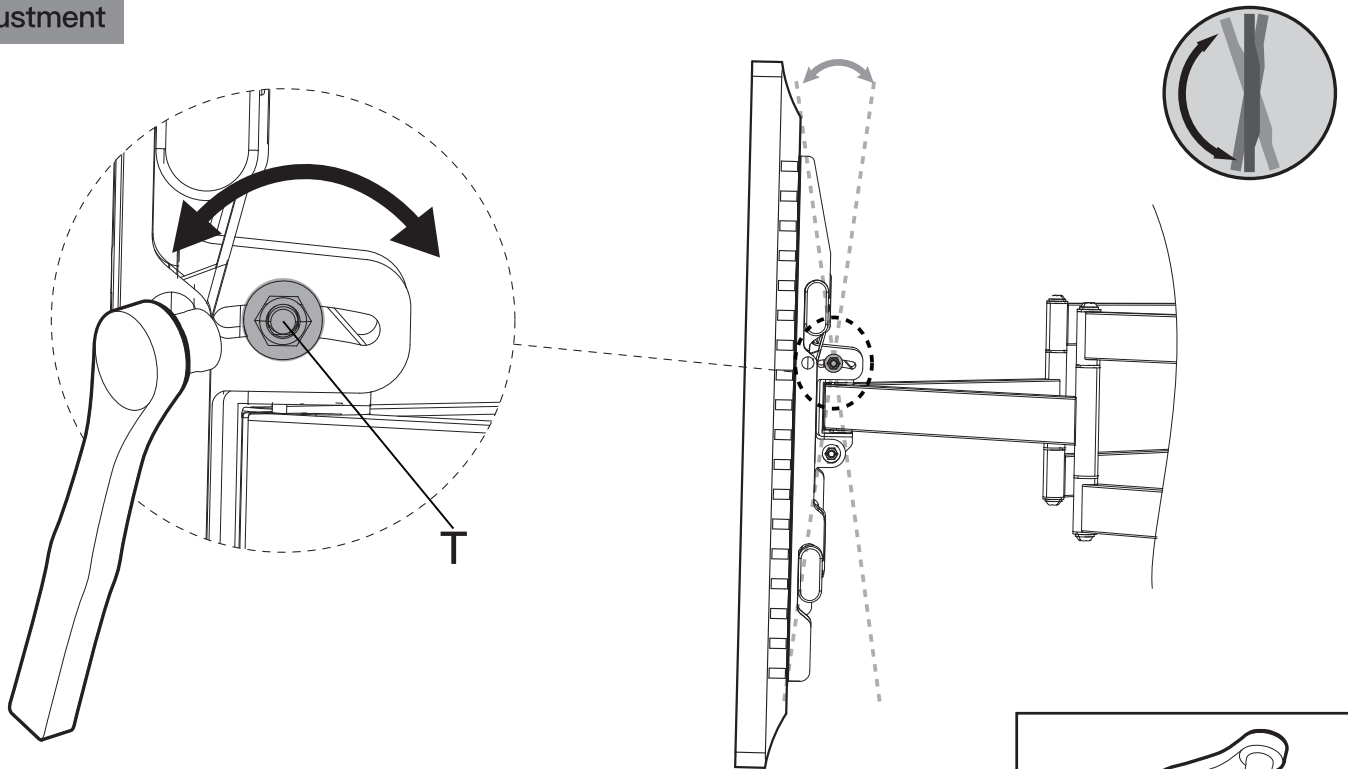

1. Slightly loosen two tilting Nuts [T] using a socket wrench.
2. Adjust TV to your desired tilt angle.
3. Retighten the two tilting Nuts [T] using the socket wrench to secure TV in place.



Level Adjustment

If needed, the TV can be levelled.

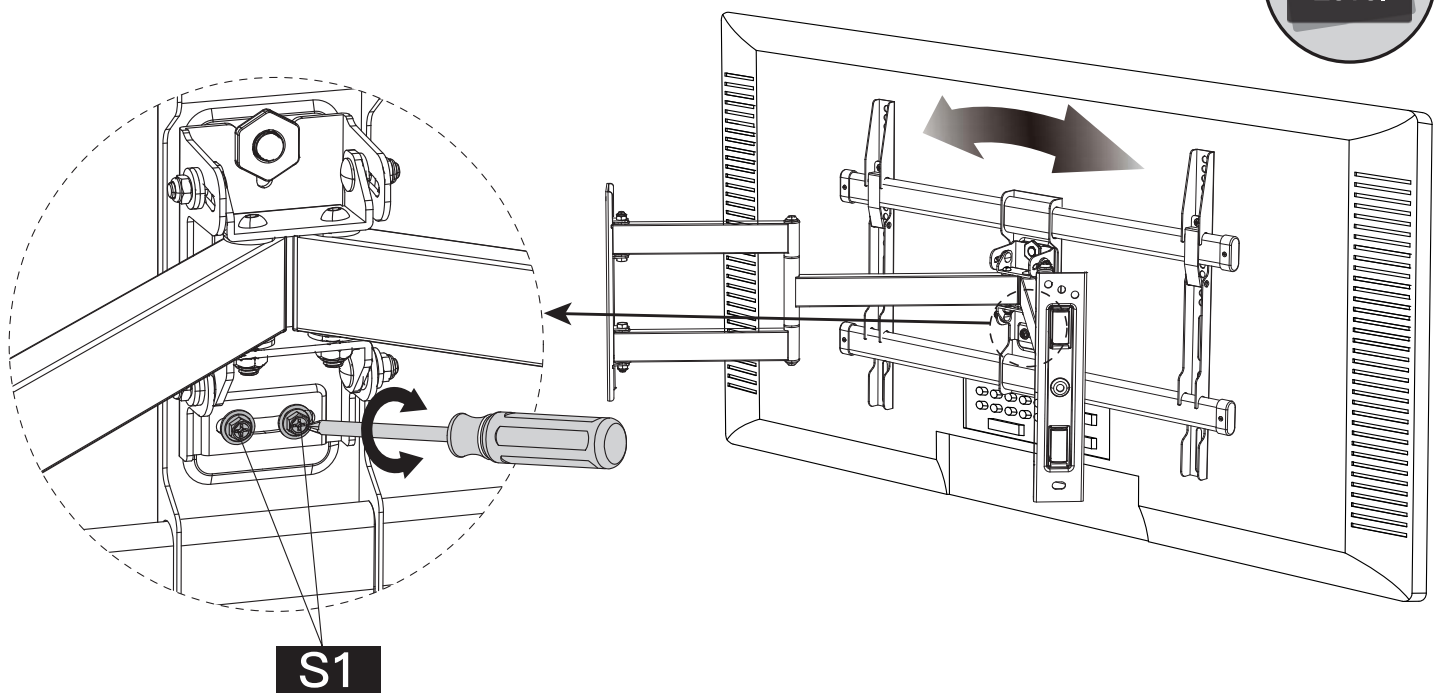

1. Slightly loosen the two Bolts [S1] on the rear of the Front Support.
2. Level your TV.
3. Retighten both Bolts [S1] to hold TV in place.



Swivel Adjustment

Middle Location

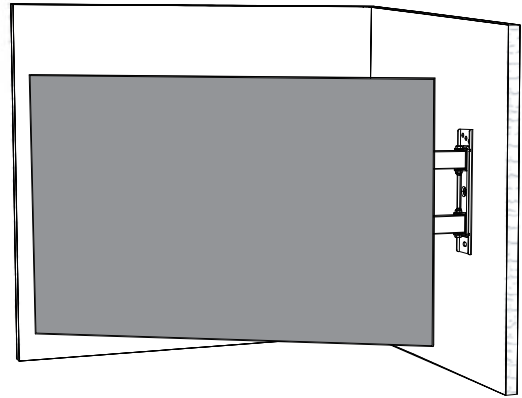
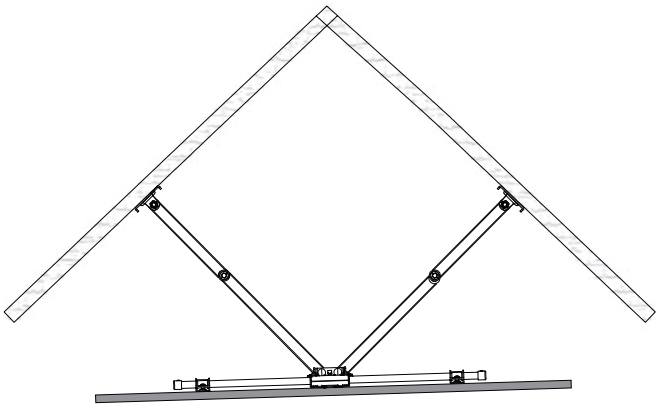

Left Side Swivel

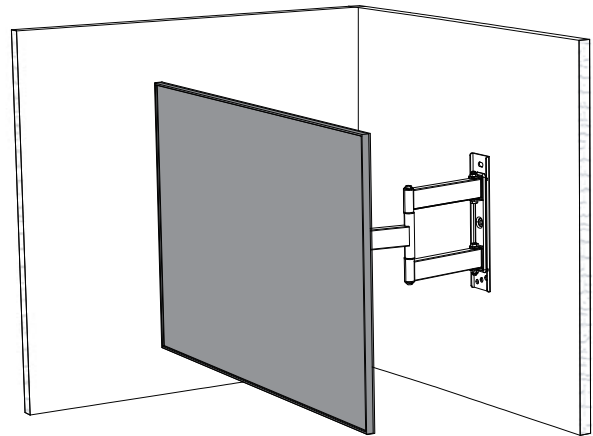
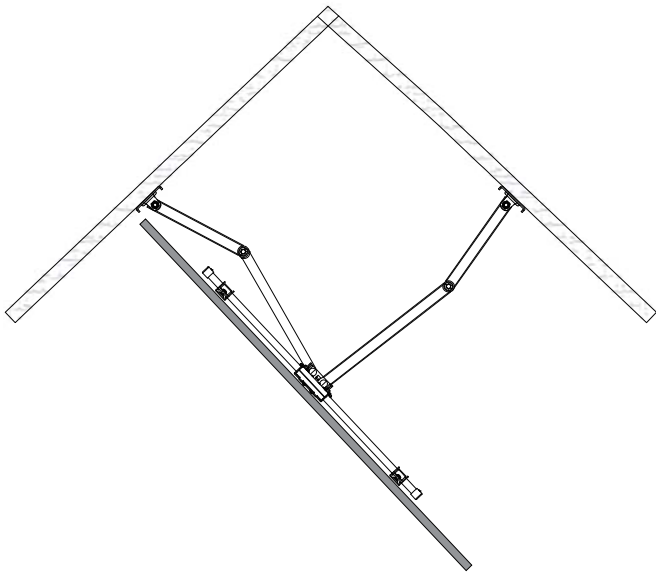

Right Side Swivel

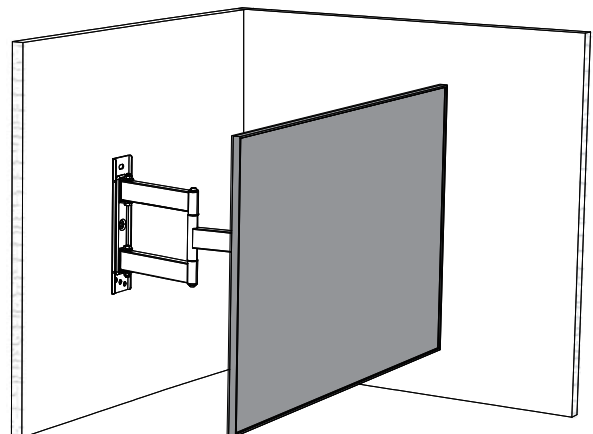
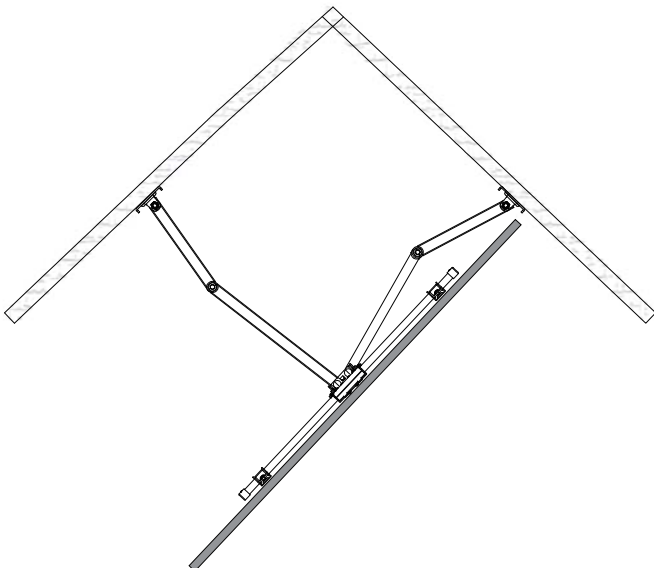

CONSIGNES DE SECURITE IMPORTANTES

⚠ DANGER! Veuillez lire attentivement toutes les instructions avant de tenter l'installation. Si les instructions ne vous semblent pas claires ou si vous avez des questions, veuillez contacter notre service d'assistance technique au (877) 419-7832 ou notre service clientèle à l'adresse support@ergoav.com.

⚠ ATTENTION : L'utilisation avec des produits plus lourds que les poids maximums indiqués peut entraîner une instabilité et des blessures possibles.

- N'utilisez pas ce produit à des fins qui ne sont pas explicitement spécifiées dans ce manuel. Ne dépassez pas la capacité de charge. Nous ne sommes pas responsables des dommages ou blessures causés par un montage incorrect, un assemblage incorrect ou une utilisation inappropriée.
- Ce produit est conçu pour être utilisé dans les murs à ossature de bois et les murs en béton massif. – NE PAS installer dans une cloison sèche seule
- Le mur doit être capable de supporter quatre fois le poids du TV et du support combinés.
- Utilisez ce système de montage uniquement pour l'usage auquel il est destiné, tel que décrit dans ces instructions. N'utilisez pas d'accessoires non recommandés par le fabricant.
- Ne pas utiliser à l'extérieur.
- Acheminez correctement les cordons et les câbles pour éviter tout dommage mécanique.
- SAUVEGARDER CES INSTRUCTIONS.

Restrictions de poids



Si votre téléviseur pèse plus lourd, n'utilisez pas ce produit.

⚠ AVERTISSEMENT

NE PAS dépasser le poids maximum indiqué. Ce support TV est destinée à être utilisé uniquement dans la limite des poids maximums indiqués. L'utilisation de produits plus lourds que les poids maximums indiqués peuvent entraîner une défaillance du support TV et de ses accessoires, et provoquer des dommages et / ou des blessures.

Vérifiez le modèle VESA du TV avant l'installation

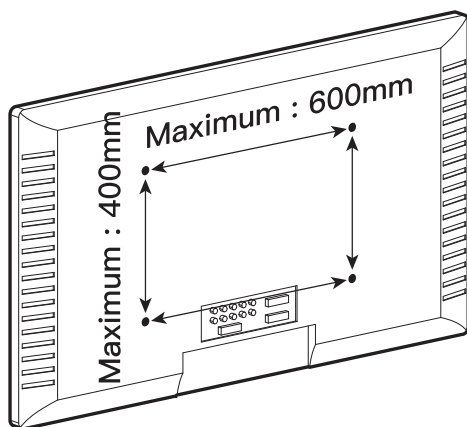

100 mm ≈ 4 pouce
200 mm ≈ 7 7/8 pouce
300 mm ≈ 11 3/4 pouce
400 mm ≈ 15 3/4 pouce
600 mm ≈ 23 3/5 pouce

Minimum: 200mm x 100mm /
8 pouce x 4 pouce (W x H)

Maximum: 600mm x 400mm /
24 pouce x 16 pouce (W x H)

Si le motif VESA de votre Téléviseur est inférieur à 200mm x 100mm ou supérieur à 600mm x 400mm, ce support n'est PAS COMPATIBLE avec votre Téléviseur. Veuillez contacter notre support technique au (877) 419-7832 ou support@ergoav.com pour trouver un support compatible.

Outils nécessaires (non inclus)



Détecteur
de goujons



Ailette



Mètre ruban

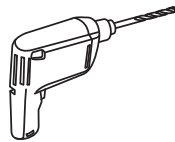

Foreuse



Crayon

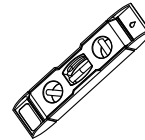

Niveau



Tournevis
Phillips



7/32 pouce
(5.5mm)
Foret à bois



3/8 pouce
(10mm)
Clé à douille



1/2 pouce
(13mm)
Clé à douille

(Nécessaire pour les installations
en béton)



3/8 pouce (10mm)
Foret à béton



Marteau-
piqueur

Vérifiez la construction de vos murs

ATTENTION

NE PAS
installer dans
une cloison
sèche seule.

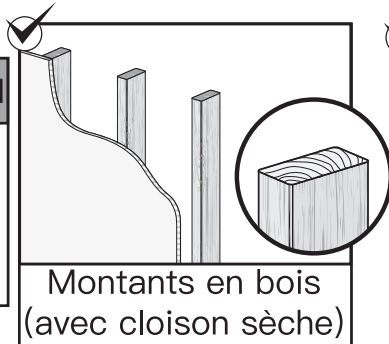

Montants en bois
(avec cloison sèche)

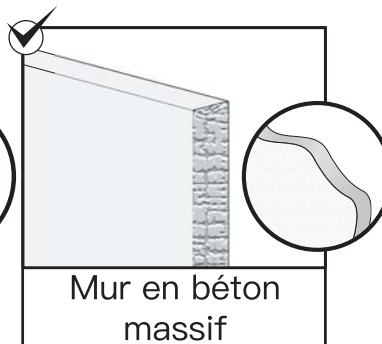

Mur en béton
massif

Si vous n'êtes pas sûr
de la construction du
mur, veuillez contacter
notre ligne d'assis-
tance technique au
(877) 419-7832 ou
notre service clientèle à
l'adresse
support@ergoav.com.

Pièces et matériel fournis

AVERTISSEMENT : Ce produit contient des petits objets susceptibles de présenter un risque d'étouffement en cas d'ingestion.

Avant de commencer l'assemblage, vérifiez que toutes les pièces sont incluses et en bon état. N'utilisez pas de pièces endommagées ou défectueuses. Si vous avez besoin de pièces de rechange, veuillez contacter notre ligne d'assistance technique au (877) 419-7832 ou notre service clientèle à l'adresse support@ergoav.com.

• Veuillez noter : le matériel inclus dans cet ensemble ne sera pas utilisé en totalité.

Pièces et matériel fournis pour l'étape 1

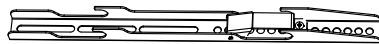

Support TV

01 x 2

REMARQUE : Les rondelles et les entretoises indiquées sont de taille réelle.

Rondelle

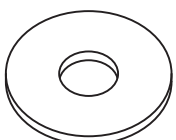

M4 / M5
[B1] x 4

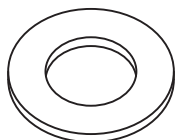

M6 / M8
[B2] x 4



L2.5mm
[F1] x 8

Entretoises

[Si nécessaire]

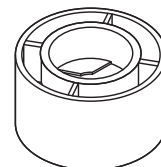

L10mm
[F2] x 4

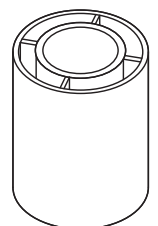

L22mm
[F3] x 4

Boulons de téléviseur (une seule taille de boulon convient à votre Téléviseur)

REMARQUE : Les boulons sont représentés en taille réelle.

M4

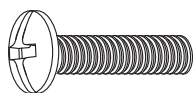

M4 x 12mm
[C1] x 4

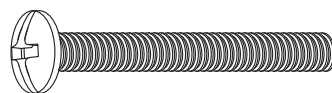

M4 x 30mm
[C2] x 4

M6

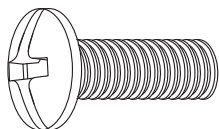

M6 x 15mm
[D1] x 4

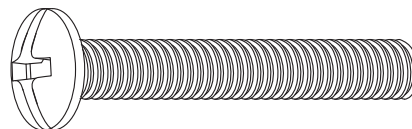

M6 x 35mm
[D2] x 4

M8

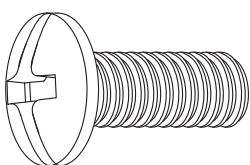

M8 x 15mm
[E1] x 4

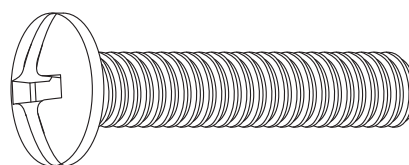

M8 x 35mm
[E2] x 4

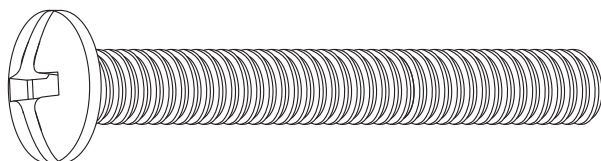

M8 x 50mm
[E3] x 4

Étape 1 Fixez les supports du téléviseur sur le téléviseur

Sélectionnez les boulons TV

Une seule taille de boulon convient à votre téléviseur.

M4



M6



M8

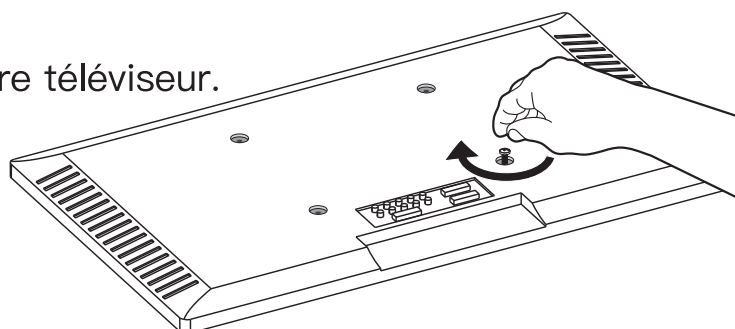

REMARQUE : Ne serrez pas trop les boulons de TV pour ne pas l'endommager.

Longueur de la vis : vérifiez que le filetage est correctement engagé avec les boulons ou la combinaison vis / entretoises. Nous recommandons un engagement du filetage sur au moins 5 tours.

- Trop court, le TV ne sera pas maintenu.
- Trop long, le TV sera endommagé.

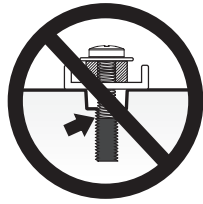

Trop court

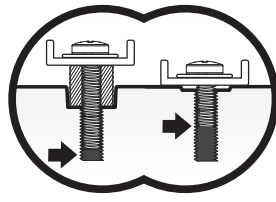

Correct



Trop long

REMARQUE : lors de l'utilisation des entretoises, il est important de noter qu'elles peuvent être utilisées sur plusieurs couches (c'est-à-dire empilées). Si vous rencontrez des difficultés pour comprendre comment installer les boulons ou les entretoises du TV, veuillez contacter notre service d'assistance technique au (877) 419-7832 ou notre service clientèle à l'adresse support@ergoav.com.

Les pièces nécessaires si vous avez un téléviseur tel qu'indiqué ci-après.

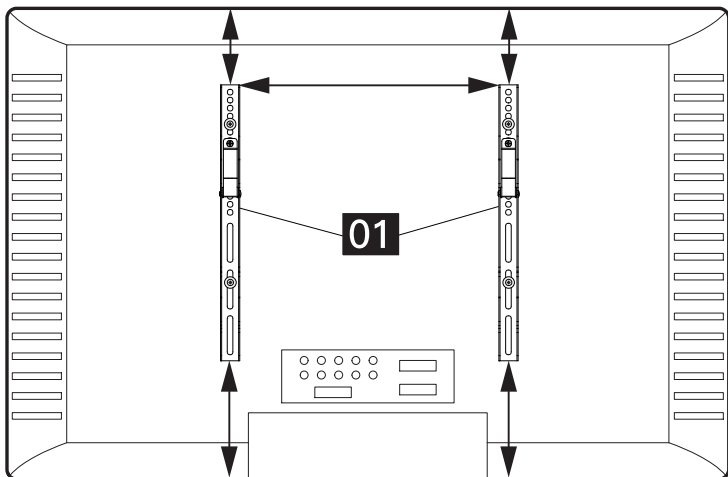
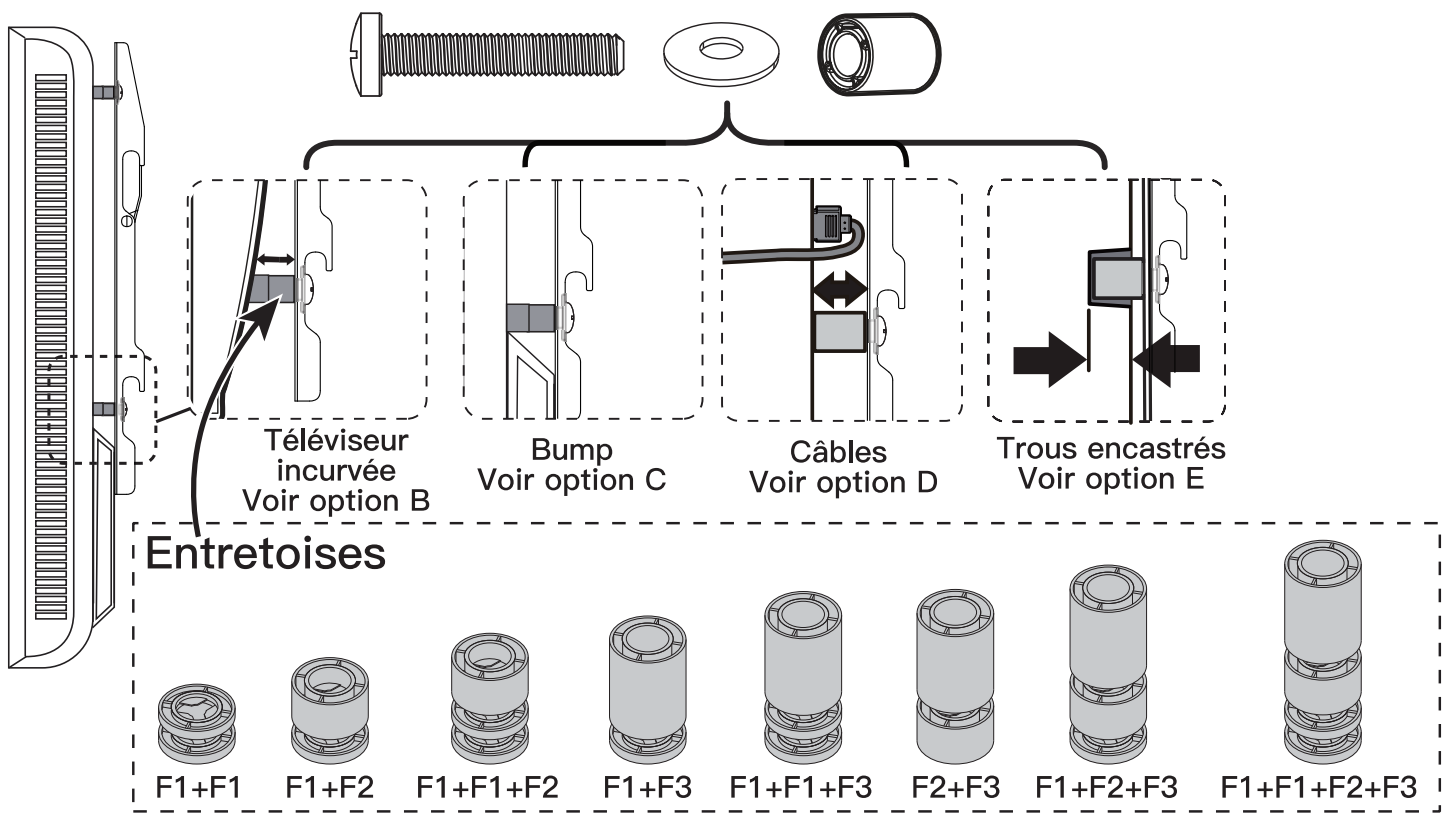

⚠ ATTENTION : Lorsque vous fixez les supports TV à l'arrière du téléviseur, assurez-vous que les flèches vers le haut sont dirigées vers le haut du téléviseur et qu'elles sont également centrées sur l'arrière du téléviseur.

⚠ EUILLEZ NOTER : Les emplacements des trous de boulon sur votre téléviseur peuvent varier en fonction du design du fabricant du téléviseur. Nous représentons seulement les emplacements possibles des trous des boulon.

Option A (pour un téléviseur à dos plat)

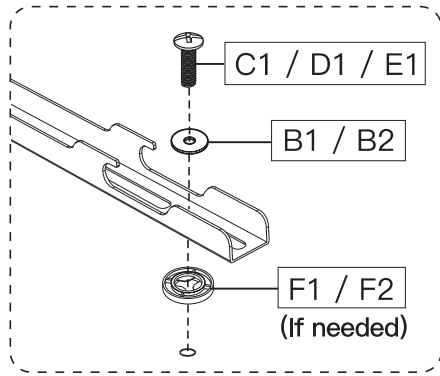

Reportez-vous aux instructions d'entretoise de la page 19, si nécessaire.

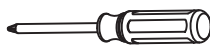

+ 
Tournevis Phillips
(Non inclus)

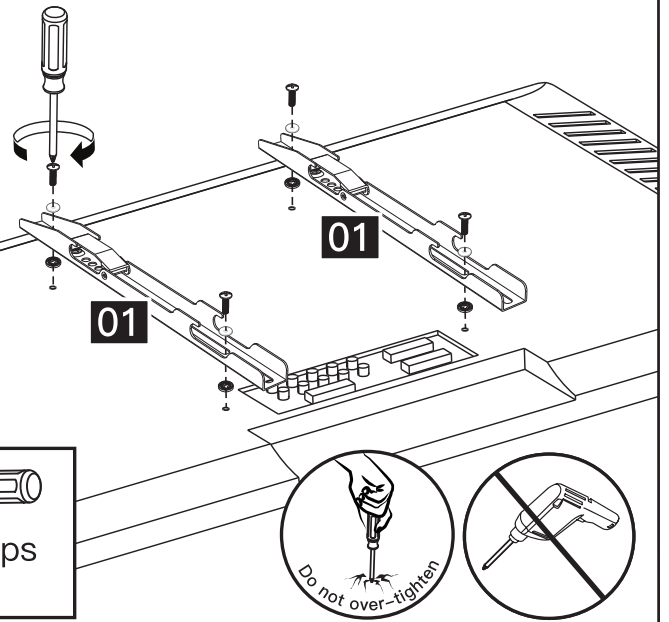

Option B (pour un téléviseur à dos arrondi)

La hauteur des entretoises doit être suffisante pour éviter que la courbe à l'arrière du téléviseur n'interfère avec la plaque de montage.

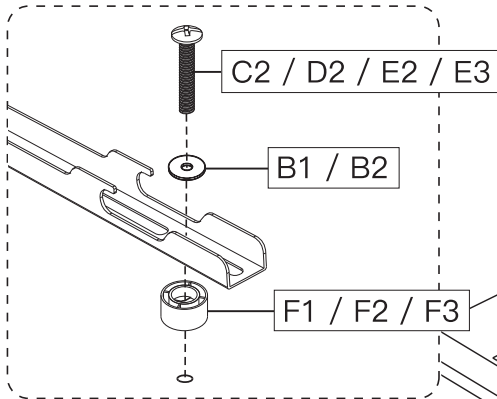

Reportez-vous aux instructions d'entretoise de la page 19, si nécessaire.

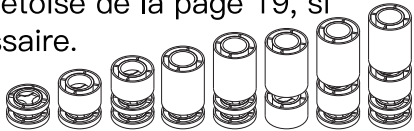

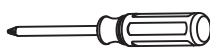
+ 
Tournevis Phillips
(Non inclus)

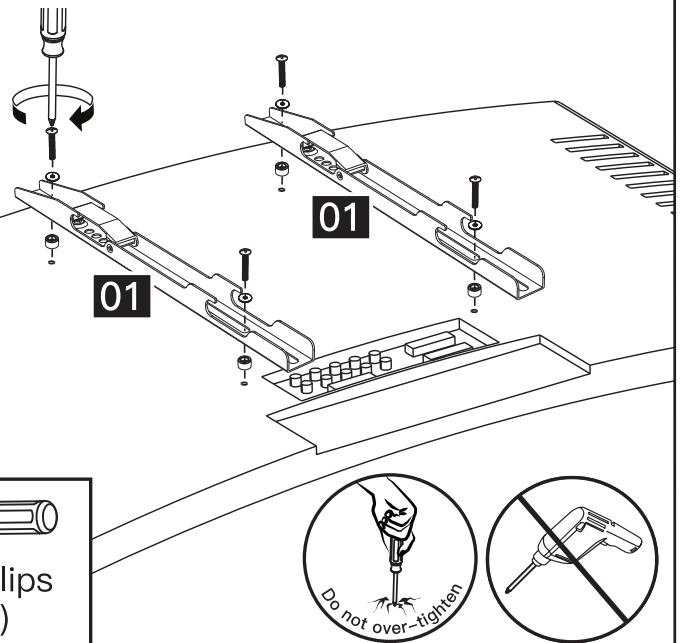

Option C (pour un téléviseur avec une surépaisseur)

Les entretoises doivent être suffisamment hautes pour qu'il n'y ait pas d'espace entre le support TV et la bosse à l'arrière du Téléviseur.

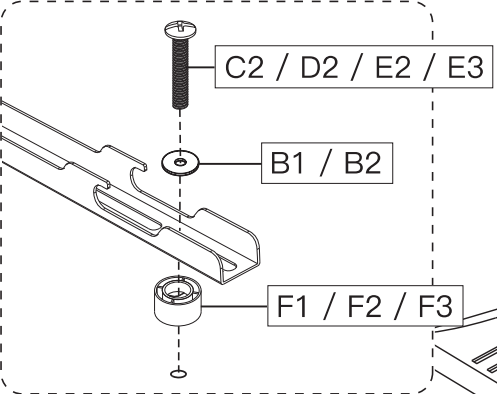

Reportez-vous aux instructions d'entretoise de la page 19, si nécessaire.

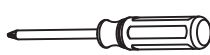

+ 
Tournevis Phillips
(Non inclus)

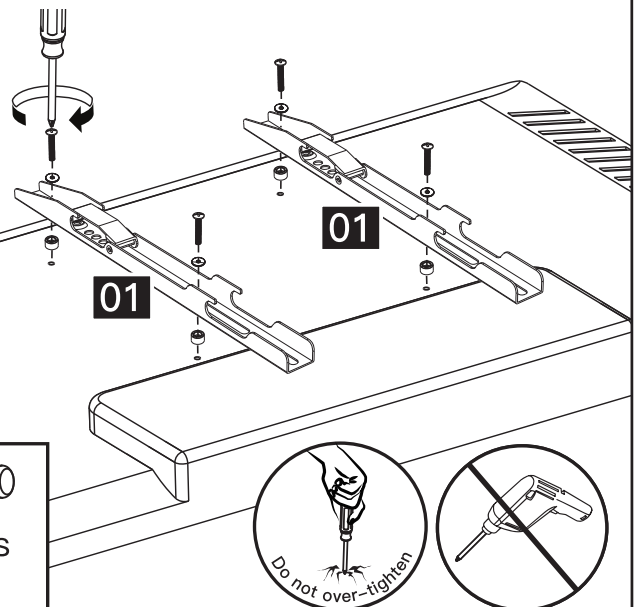

Option D (pour téléviseur avec interférence du câble)

Pour éviter les interférences entre les câbles, utilisez les entretoises pour créer un espace supplémentaire entre le téléviseur et les supports TV.

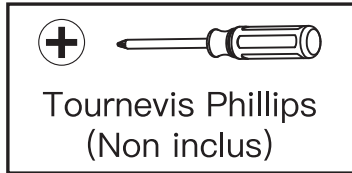
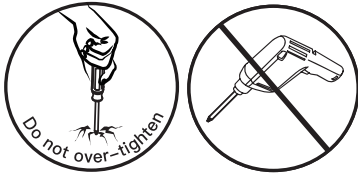

Reportez-vous aux instructions d'entretoise de la page 19, si nécessaire.

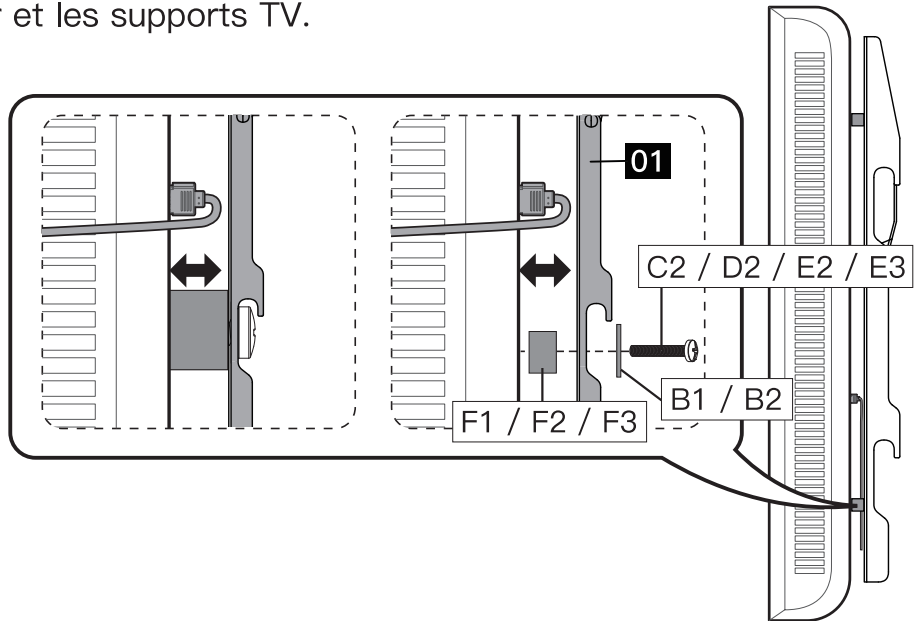

Option E (Pour les trous encastrés)

L'entretoise doit remplir les trous en retrait sur la base du téléviseur afin que les supports TV soient aussi proches que possible du téléviseur.

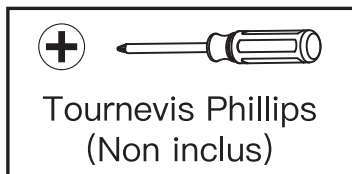
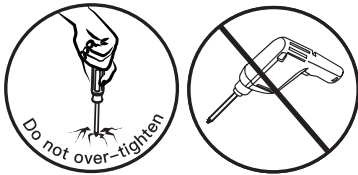

Reportez-vous aux instructions d'entretoise de la page 19, si nécessaire.

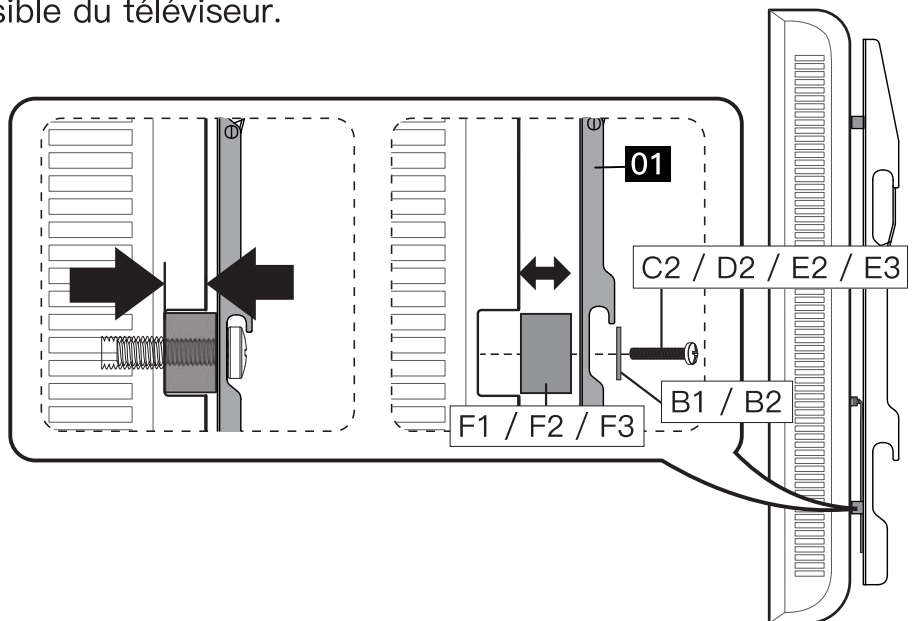

Pièces et matériel fournis pour l'étape 2

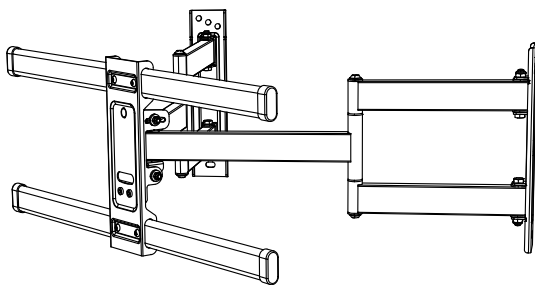

Assemblage de bras / plaque murale

02 x 1

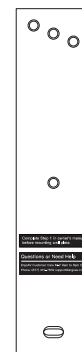

Modèle de plaque murale **03** x 2

REMARQUE : Le tire-fond est représenté en taille réelle.

A1 x 6 Tire-fond
5/16 pouce x 2 3/4 pouce

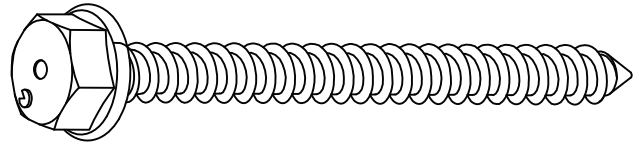

A2 x 6 Ancre de mur
10 x 60mm

⚠ ATTENTION!
Cet ancrage est destiné
aux murs en béton **UNIQUE**
MENT. NE PAS les utiliser
dans des cloisons sèches
ou les montants en bois.

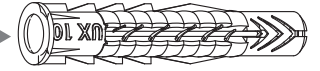

Étape 2 Fixation de l'Assemblage de bras / Plaque murale au mur

Pour l'installation de montants en bois, suivre l'ÉTAPE 2A.

Pour l'installation de béton, suivre l'ÉTAPE 2B.

Étape 2A Option montants en bois

⚠ AVERTISSEMENT :

- Évitez les blessures corporelles ou les dommages matériels potentiels! NE SERREZ PAS trop les tire-fonds [A1]. Ne serrez les tire-fonds [A1] que jusqu'à ce qu'ils soient fermement tirés contre la plaque murale et le mur.
- N'utilisez pas de perceuse pour serrer les tire-fonds ! Utilisez uniquement une clé à douille.
- NE PAS UTILISER L'ANCRAGE [A2] POUR CETTE ÉTAPE.
- Assurez-vous que la plaque murale est bien fixée au mur avant de passer à l'étape suivante.
- Taille nominale des montants en bois: commun 2 x 4 pouce (51 x 102mm).
- Le centre des montants doit être vérifié.



2A-1

REMARQUE : Lorsque vous utilisez des supports d'angle : Trouvez l'emplacement de vos goujons, marquez-les, puis posez le support sur le sol. Configurez-le en fonction de l'emplacement de vos montants avant de l'installer et assurez-vous que votre Téléviseur s'adapte à l'emplacement souhaité.

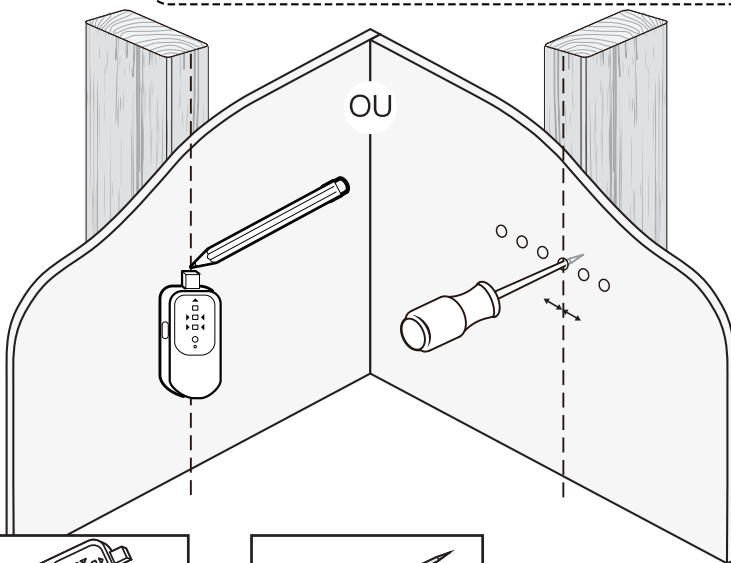

Détecteur de
goujons
(Non Inclus)

OU

Ailette
(Non Inclus)

Utilisez un détecteur de montants pour localiser les montants en bois ou utilisez une alène pour vérifier les bords. Marquez les emplacements du bord et du centre.

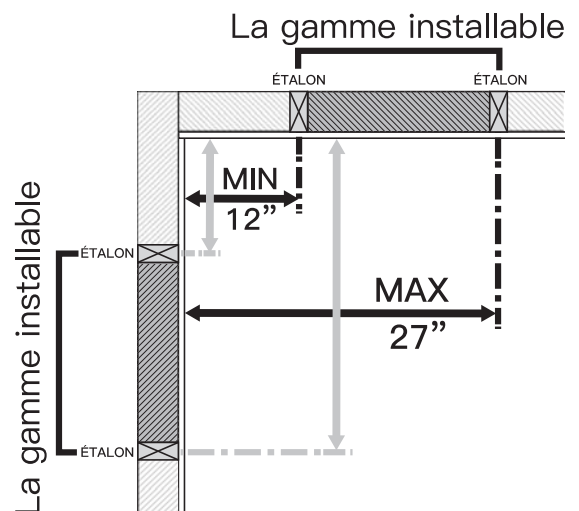

2A-2

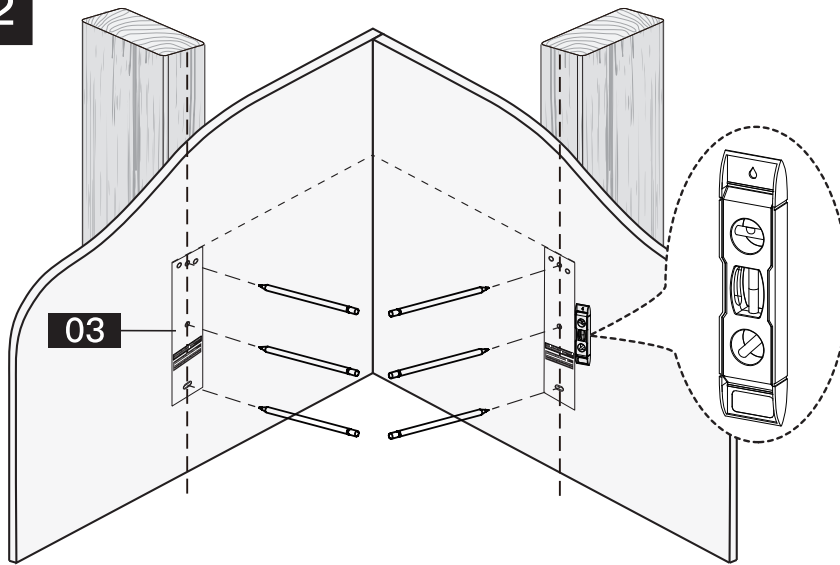

Positionnez le modèle de plaque murale [03] à la hauteur souhaitée et alignez les trous avec la ligne centrale de votre montant. Mettez à niveau le modèle de plaque murale [03] et marquez les trous.

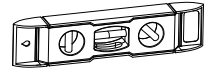

Niveau
(Non inclus)

2A-3

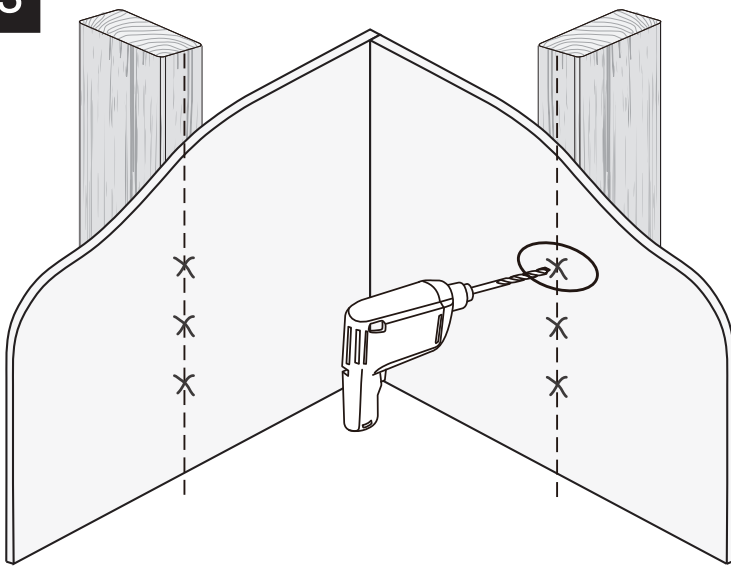

Percez 6 trous pilotes à l'aide d'un foret de 7/32 pouce (5.5mm) de diamètre. Assurez-vous que la profondeur n'est pas inférieure à 2 3/4 pouce (70mm).

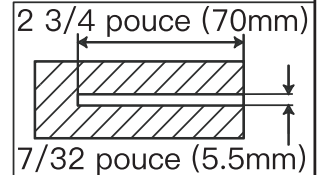

2A-4

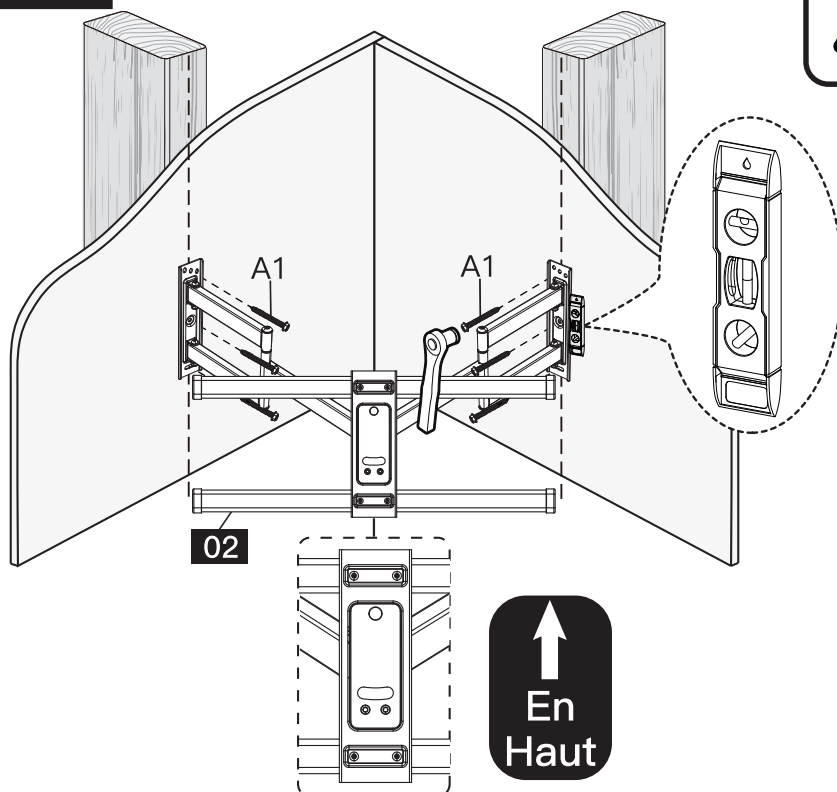

LOURD ! vous aurez peut-être besoin d'aide pour cette étape.

REMARQUE : N'utilisez pas de perceuse pour serrer les tire-fonds. Utilisez uniquement une clé à douille.

Installez l'ensemble bras / plaque murale [02] à l'aide de 6 vis de blocage [A1]. Ne serrez les vis de blocage [A1] que jusqu'à ce qu'elles soient fermement tirées contre la plaque murale et le mur.

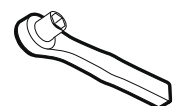
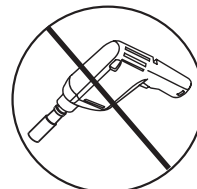

1/2 pouce (13mm)
Clé à douille
(Non inclus)



Étape 2B Option de mur en béton massif

⚠ AVERTISSEMENT :

- Évitez les blessures corporelles ou les dommages matériels potentiels ! NE SERREZ PAS trop les tire-fonds [A1]. Serrez les vis de blocage [A1] uniquement jusqu'à ce qu'elles soient fermement tirées contre la plaque murale et le mur.
- N'utilisez pas de perceuse pour serrer les tire-fonds ! Utilisez uniquement une clé à douille.
- Assurez-vous que la Assemblage de bras / plaque murale [02] est bien fixée au mur avant de passer à l'étape suivante.
- Montez la Assemblage de bras / plaque murale [02] directement sur la surface en béton sans aucun revêtement.
- L'épaisseur du mur en béton doit dépasser 5.5 pouce (140mm).



Ancre de mur
A2

2B-1

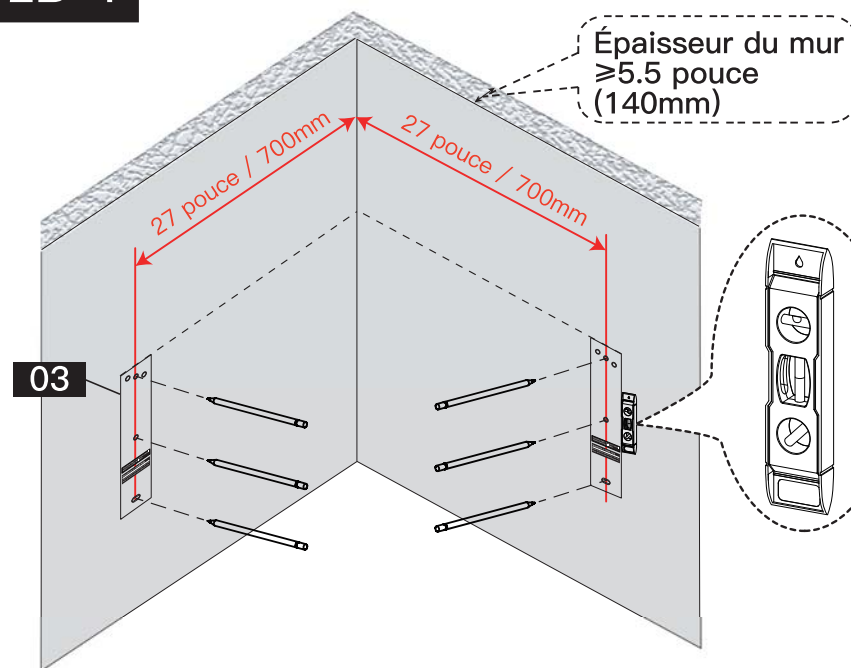

Positionnez le gabarit de plaque murale [03] à la hauteur souhaitée. Mettez à niveau le gabarit de plaque murale [03] et marquez les emplacements des trous pilotes. (la distance entre l'emplacement central et le coin du mur doit être de 27 pouce \approx 700mm)

2B-2

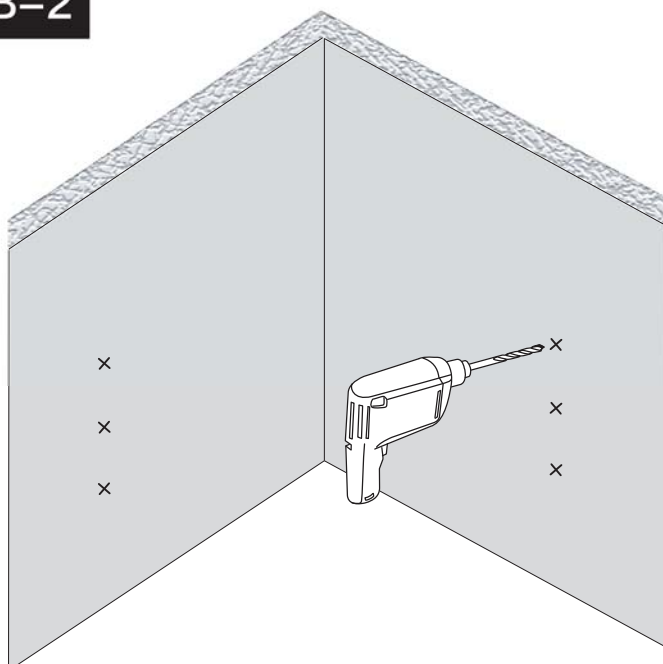

Percez 6 trous pilotes à l'aide d'un foret de 3/8 pouce (10mm) de diamètre. Assurez-vous que la profondeur n'est pas inférieure à 3 pouce (75mm).

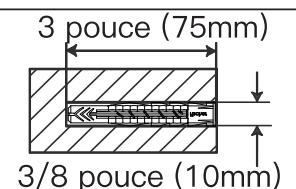
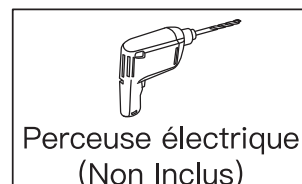

2B-3

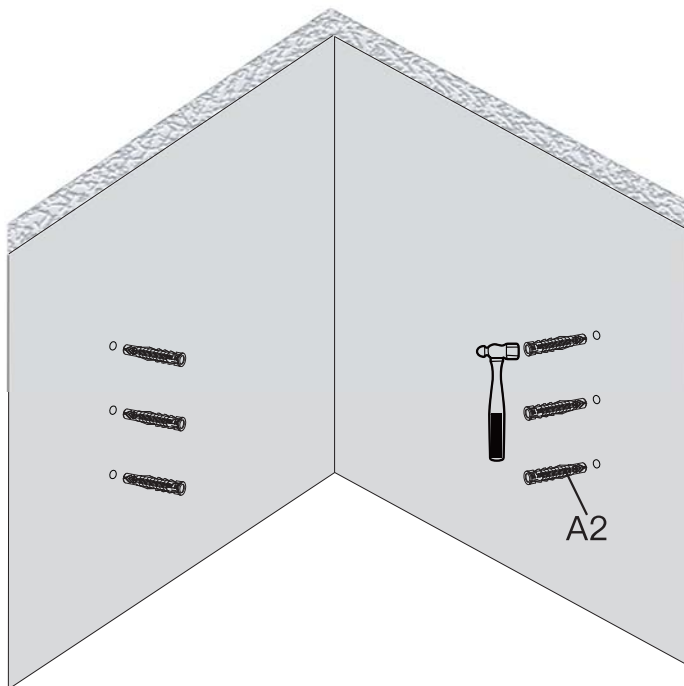

Utilisez le marteau pour enfoncer les ancrages [A2] dans le mur. Veillez à ce que les ancrages [A2] soient posés au ras de la surface du béton.



Marteau-piqueur
(Non inclus)

2B-4



LOURD ! vous aurez peut-être besoin d'aide pour cette étape.

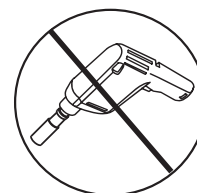
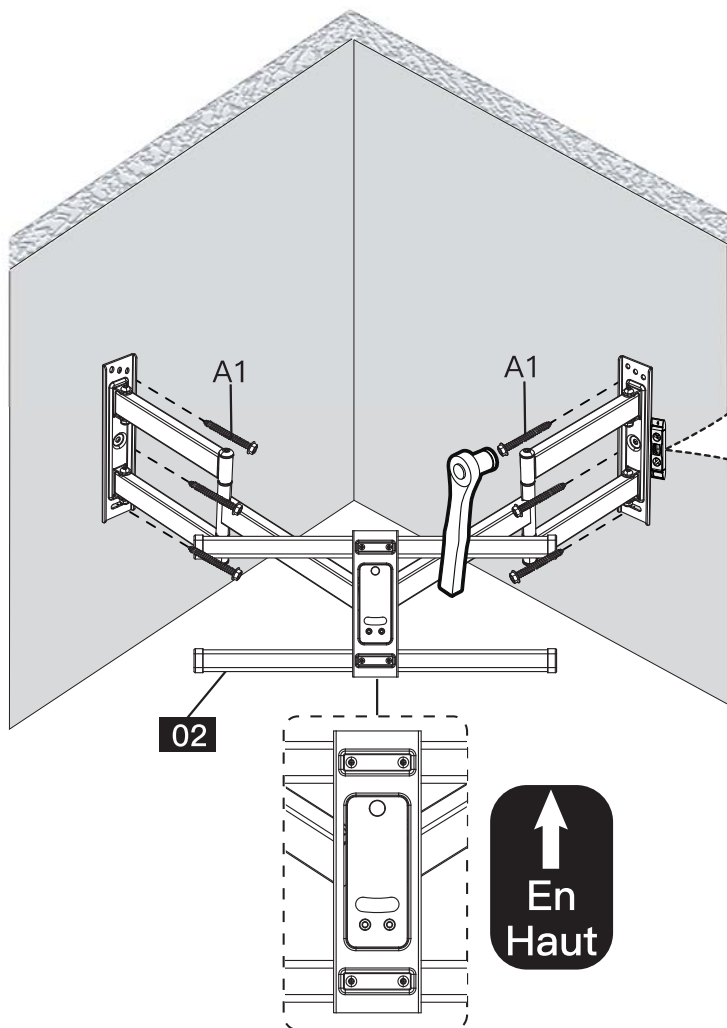

REMARQUE : N'utilisez pas de perceuse pour serrer les tire-fonds. Utilisez uniquement une clé à douille.

Installez l'ensemble bras / plaque murale [02] à l'aide de 6 vis de blocage [A1]. Serrez les vis de blocage [A1] uniquement jusqu'à ce qu'elles soient fermement tirées contre la plaque murale et le mur.



1/2 pouce (13mm)
Clé à douille
(Non inclus)

Étape 3 Fixez le téléviseur avec les attaches au support avant

3-1 Retirez les boulons préassemblés [S2] des supports du téléviseur [01] à l'aide d'un tournevis cruciforme fourni. Conservez les boulons [S2] pour les utiliser à l'étape 3-3.

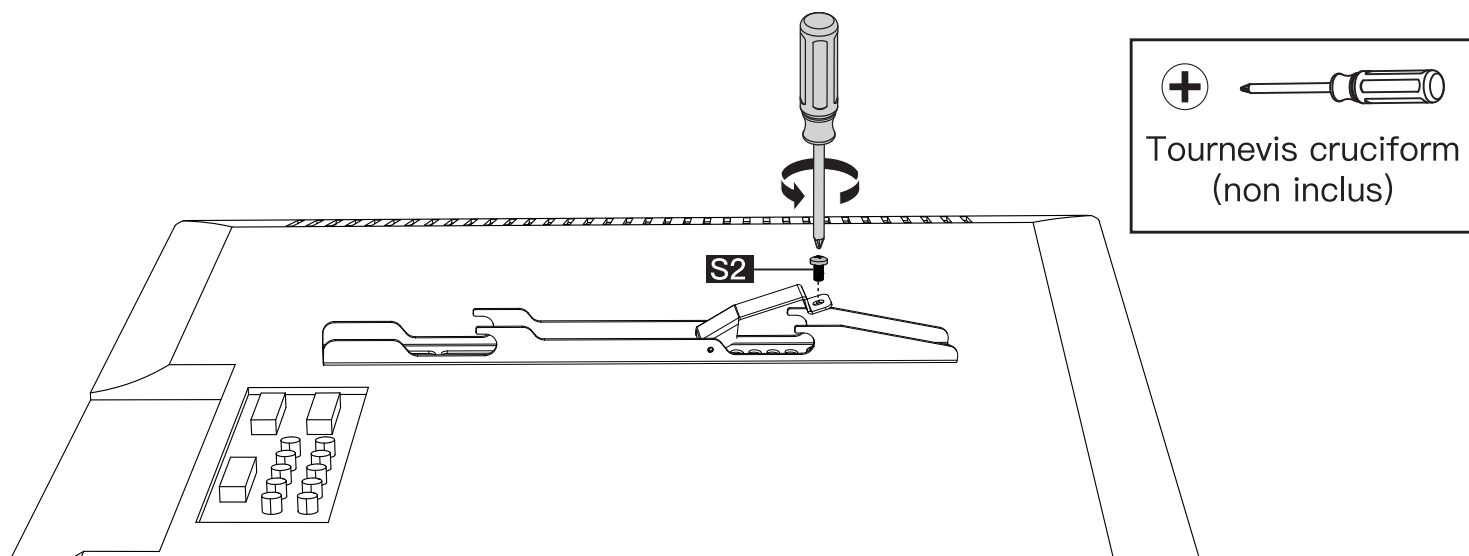

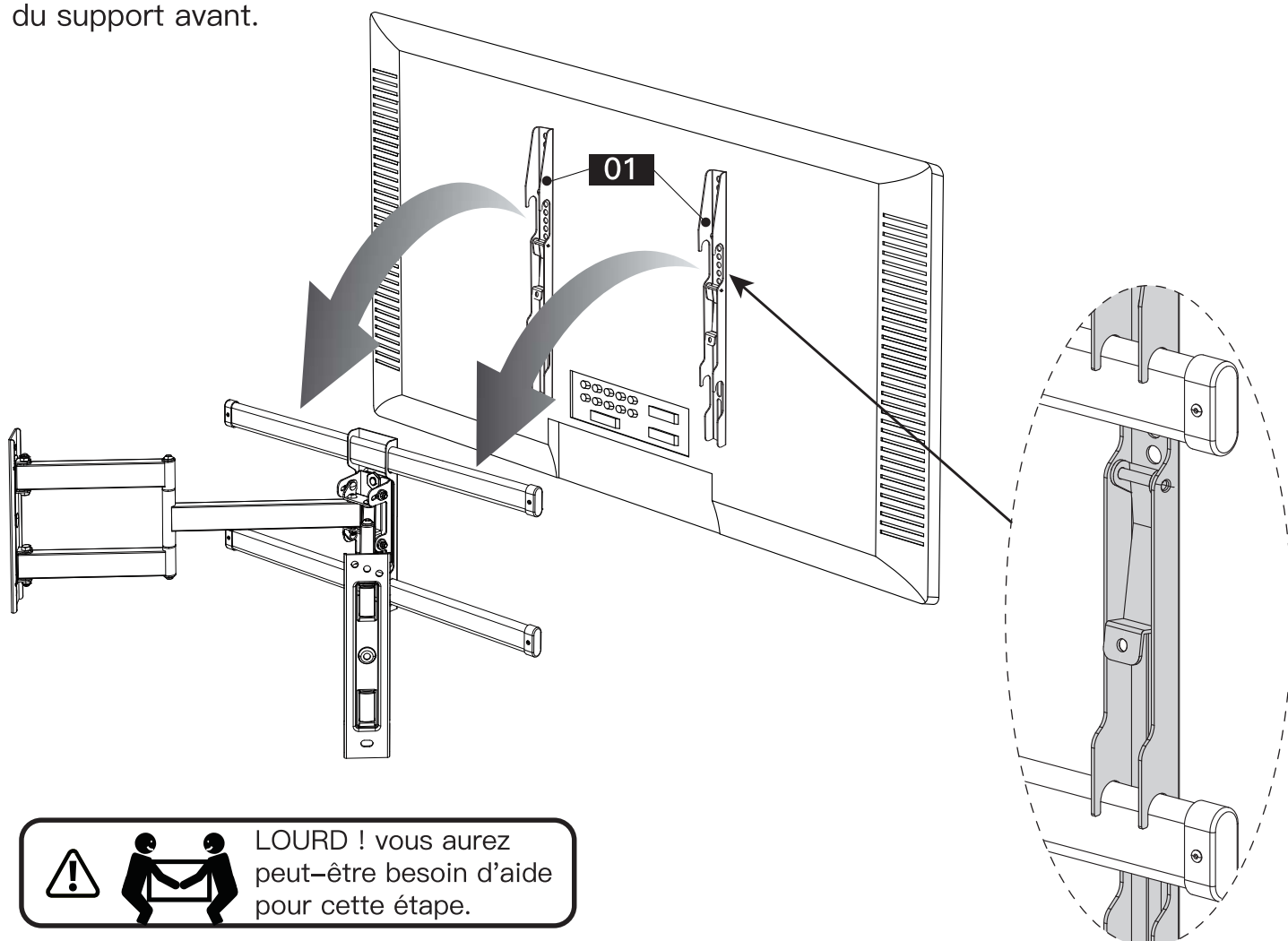

3-2 Avant de tenter de suspendre le téléviseur, assurez-vous que les languettes de verrouillage sont positionnées vers le bas du téléviseur. Accrocher le téléviseur avec les supports de téléviseur [01] sur le support avant. Assurez-vous que les attaches supérieurs et inférieurs des supports de télévision [01] se trouvent au-dessus des barres du support avant.

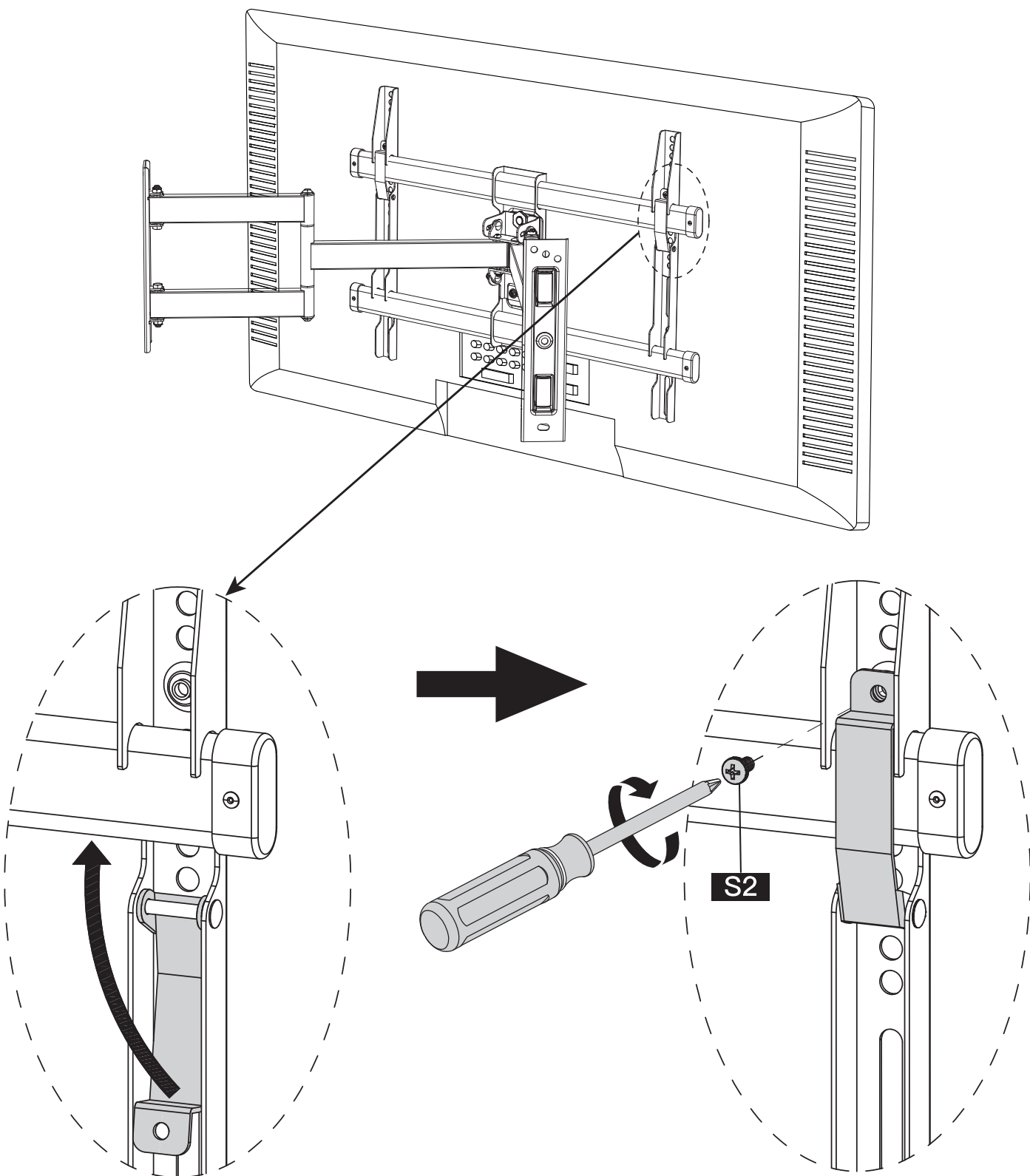

3-3 Positionnez les languettes de verrouillage vers le haut du téléviseur, puis fixez les languettes de verrouillage en place avec des boulons [S2] de l'étape 3-1. Serrez fermement les boulons [S2].

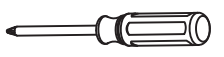

  **LOURD !** vous aurez peut-être besoin d'aide pour cette étape.

 
Tournevis cruciform (non inclus)

Étape 4 Réglages

Réglage de l'inclinaison

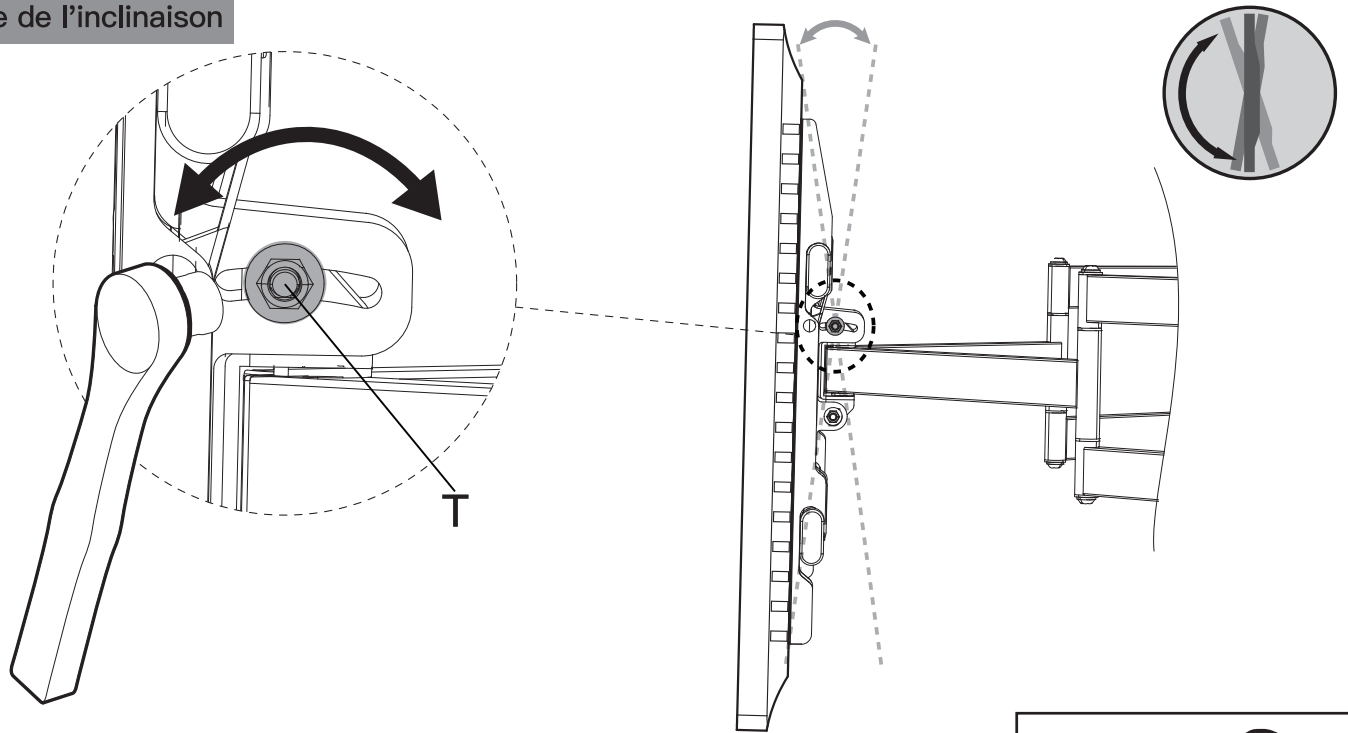

1. Dévissez légèrement deux écrous inclinables [T] à l'aide d'une clé à douille.
2. Réglez le téléviseur à l'angle d'inclinaison souhaité.
3. Resserrez les deux écrous d'inclinaison [T] à l'aide de la clé à douille pour immobiliser le téléviseur



3/8 pouce (10mm)
Clé à douille
(Non Inclus)

Réglage du niveau

Si nécessaire, le Téléviseur peut être mis à niveau.

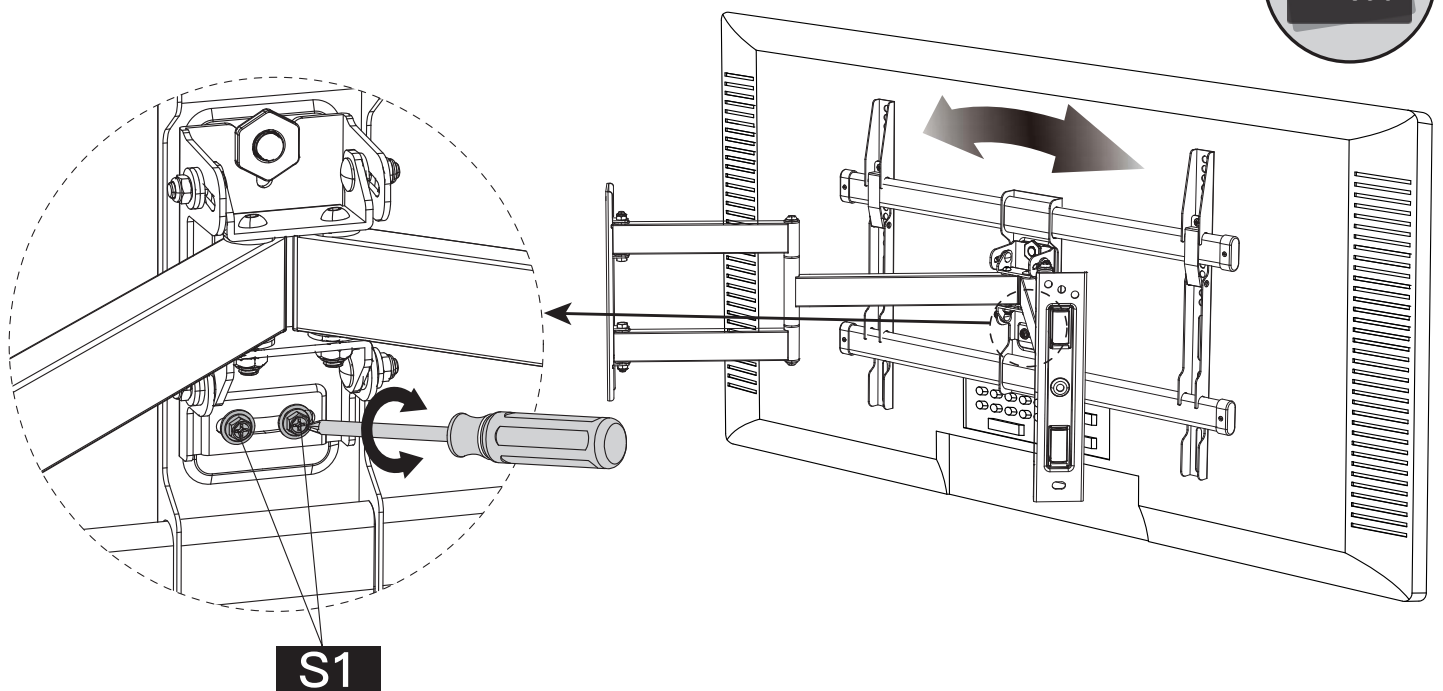

1. Desserrez d'une manière légère les deux boulons [S1] à l'arrière du support avant.
2. Mettez votre Téléviseur à niveau.
3. Resserrez les deux boulons [S1] pour que la télévision reste en place.



Tournevis
cruciform
(non inclus)

Réglage de l'orientation

Emplacement moyen

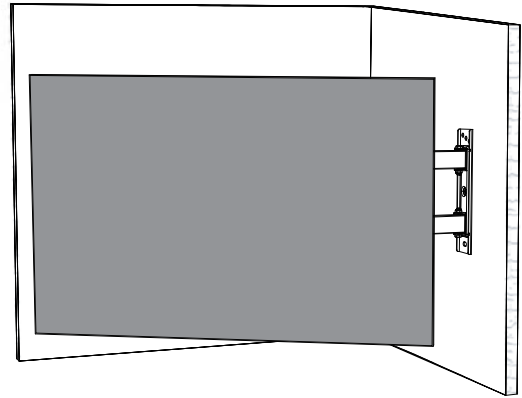
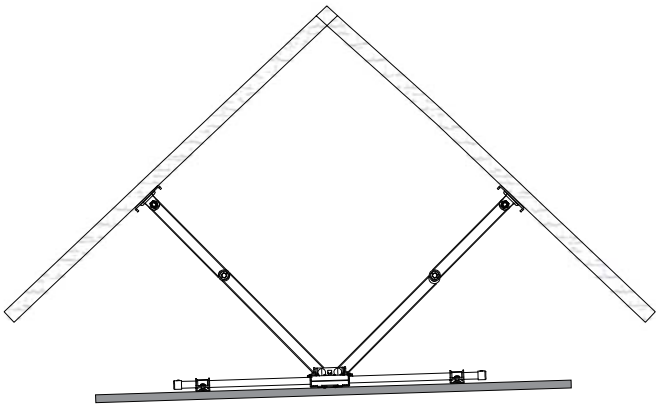

Côté gauche pivotant

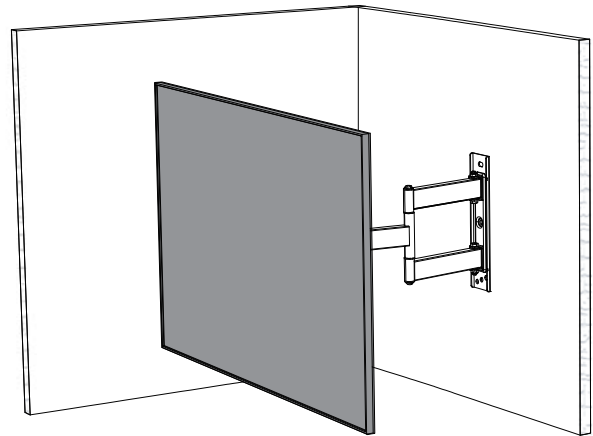
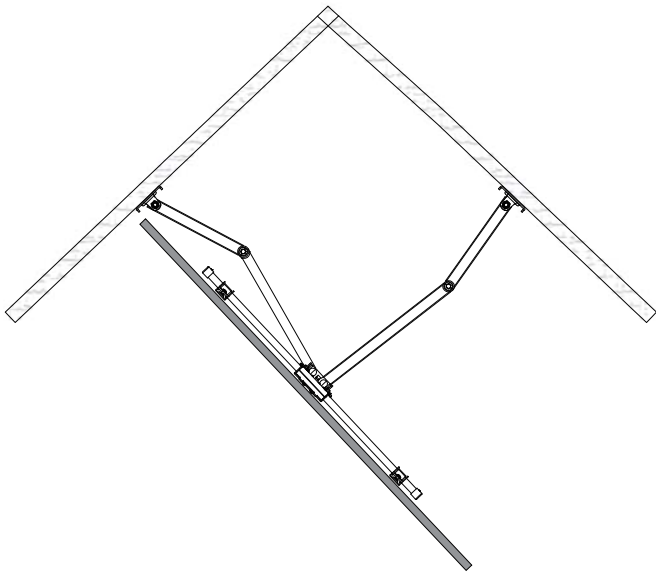

Côté droit pivotant

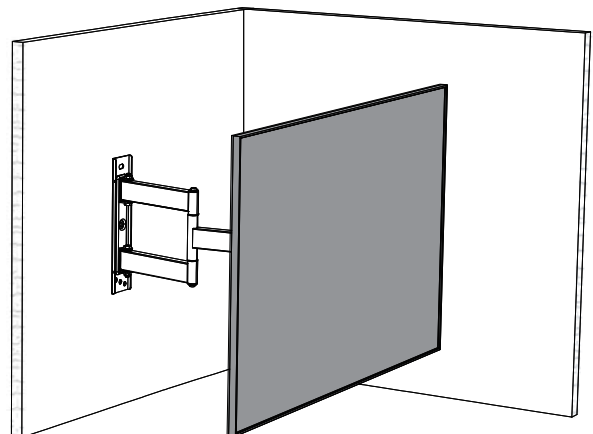
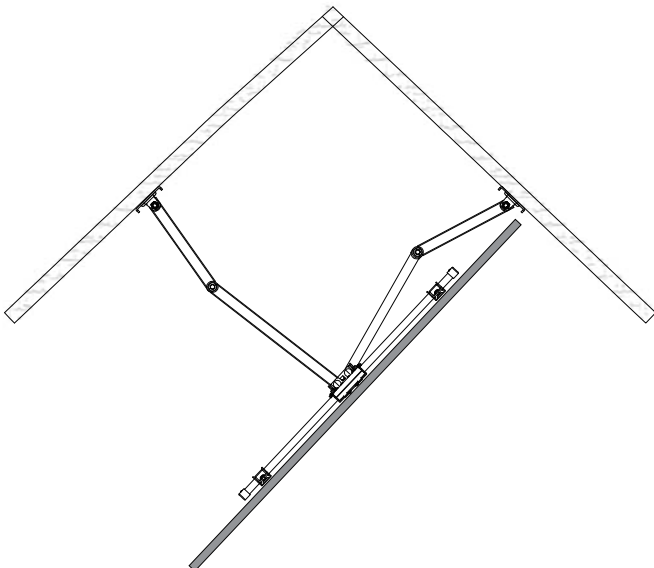

INFORMACIÓN IMPORTANTE DE SEGURIDAD

⚠ ¡PELIGRO! Por favor, lea cuidadosamente todas las instrucciones antes de realizar la instalación. Si no entiende las instrucciones o tiene alguna duda o consulta, póngase en contacto con nuestra línea de asistencia técnica llamando al (877) 419-7832, o escribiendo al servicio de atención al cliente en support@ergoav.com.

⚠ PRECAUCIÓN: El uso con productos más pesados que los pesos máximos indicados puede causar inestabilidad causando posibles lesiones.

- No utilice este producto con ningún fin que no sea el especificado explícitamente en este manual. No supere la capacidad de peso. No nos hacemos responsables de posibles daños o lesiones causados por un montaje incorrecto, errores de ensamblaje o uso inadecuado.
- Este producto está diseñado para su uso en montantes de madera y en paredes de hormigón sólido. – NO instalar solo en placa de yeso.
- La pared debe ser capaz de soportar cuatro veces el peso del televisor y del soporte juntos.
- Utilice este sistema de montaje sólo para el uso previsto, tal como se describe en estas instrucciones. No utilice accesorios no recomendados por el fabricante.
- No lo utilice en el exterior.
- Coloque los cables de forma apropiada para evitar daños mecánicos.
- **GUARDE ESTAS INSTRUCCIONES.**

Límites de peso



Si su TV pesa más, no utilice este producto.

⚠ ADVERTENCIA

NO exceda el límite máximo indicado de peso. Solo se puede utilizar este sistema de soporte si se no se sobrepasa los pesos máximos indicados. Si se utiliza con productos que sobrepasan los pesos máximos indicados es posible que el soporte y sus accesorios tengan fallas, y provoquen daños y/o lesiones.

Revise el patrón VESA de su TV antes de instalarlo

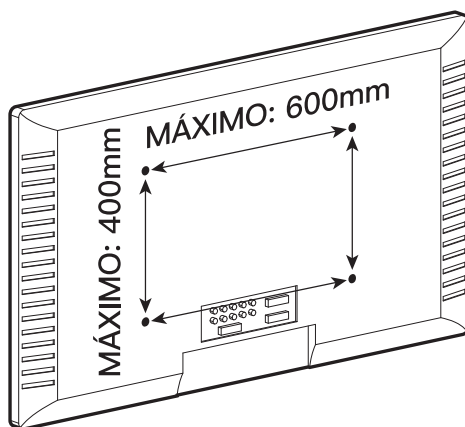

100 mm ≈ 4 pulg
200 mm ≈ 7 7/8 pulg
300 mm ≈ 11 3/4 pulg
400 mm ≈ 15 3/4 pulg
600 mm ≈ 23 3/5 pulg

Mínimo: 200mm x 100mm /
8 pulg x 4 pulg (W x H)

Máximo: 600mm x 400mm /
24 pulg x 16 pulg (W x H)

Si el patrón VESA de su Televisor es inferior a 200mm x 100mm o superior a 600mm x 400mm, significa que este soporte **NO ES COMPATIBLE**. Póngase en contacto con nuestro Servicio Técnico llamando al (877) 419-7832 o escribiendo a support@ergoav.com.

Herramientas necesarias (no incluidas)

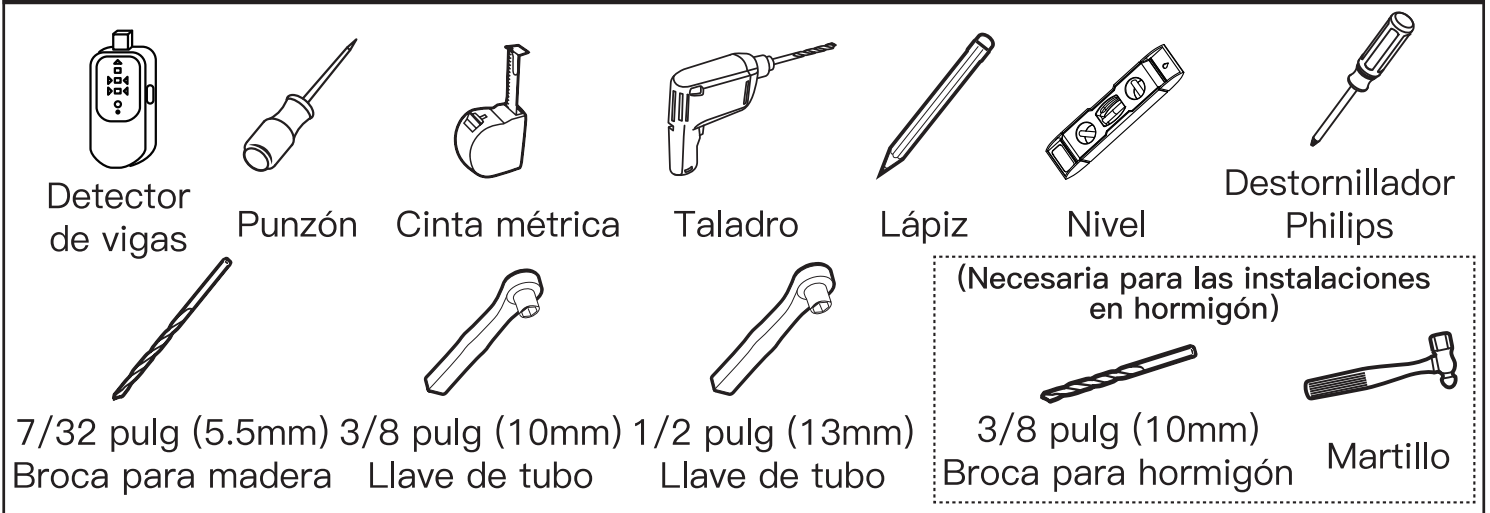

Inspeccione la construcción de su pared

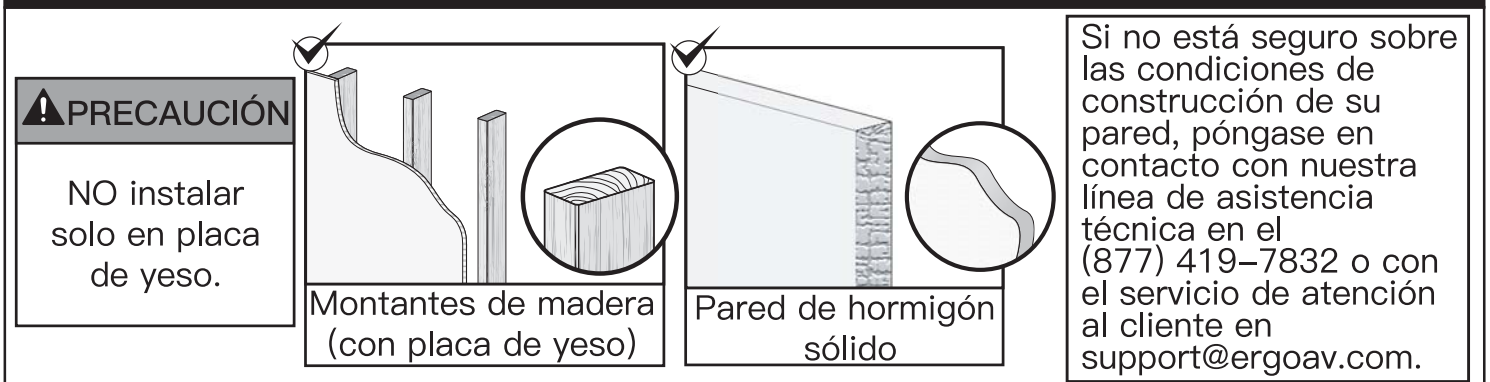

Piezas y herramientas provistas

ADVERTENCIA: Este producto contiene piezas pequeñas que pueden representar un riesgo de atragantamiento si se ingieren.

Antes de iniciar el montaje, compruebe que todas las piezas estén incluidas e intactas. No utilice piezas dañadas o defectuosas. Si necesita piezas de repuesto, póngase en contacto con nuestra línea de asistencia técnica al (877) 419-7832 o con el servicio de atención al cliente en support@ergoav.com.

- **Tenga en cuenta lo siguiente:** Es posible que no necesite usar todos los herrajes incluidos en este envase.

Piezas y herrajes suministrados para el paso 1

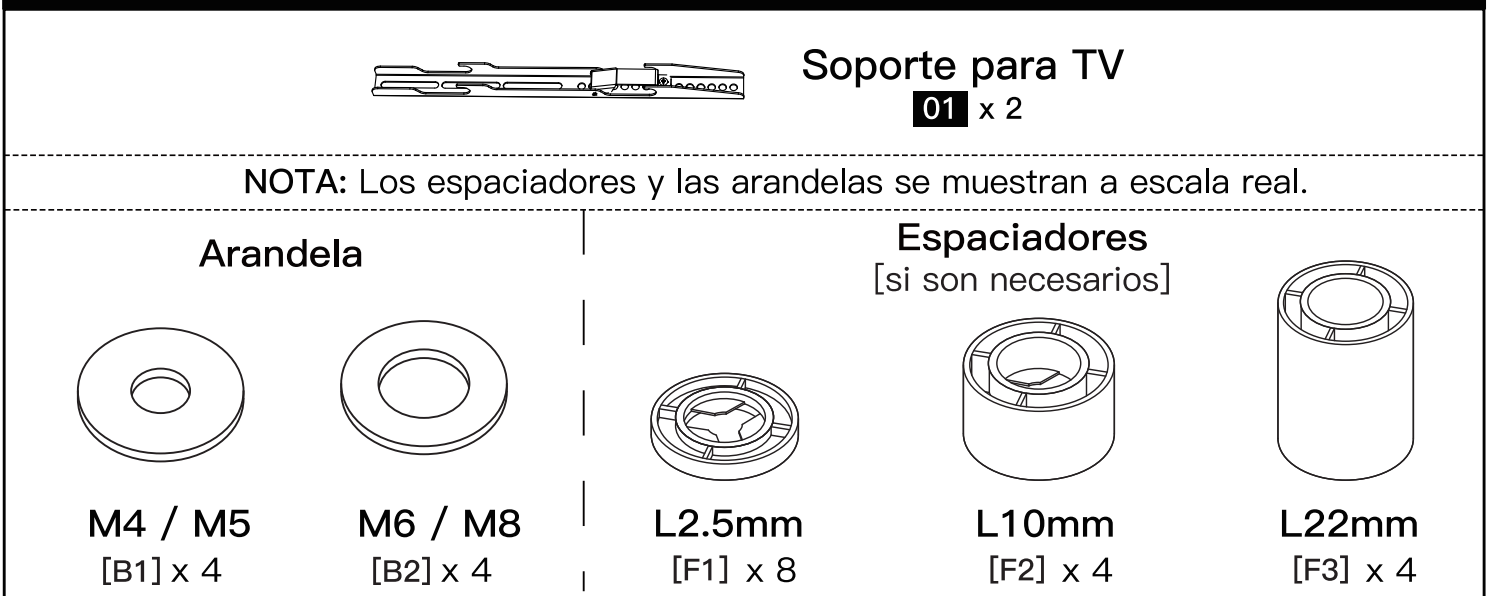

Pernos para TV (Solo un perno encaja en su Televisor)

NOTA: Los pernos se muestran en tamaño real.

M4

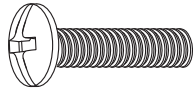

M4 x 12mm
[C1] x 4

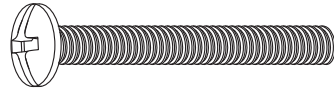

M4 x 30mm
[C2] x 4

M6

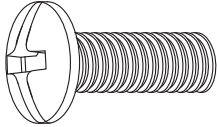

M6 x 15mm
[D1] x 4

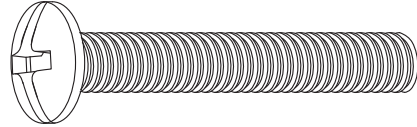

M6 x 35mm
[D2] x 4

M8

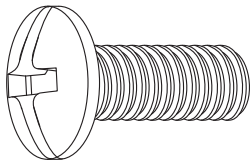

M8 x 15mm
[E1] x 4

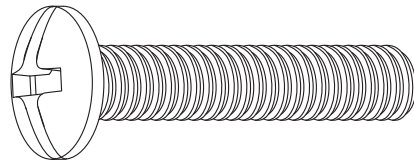

M8 x 35mm
[E2] x 4

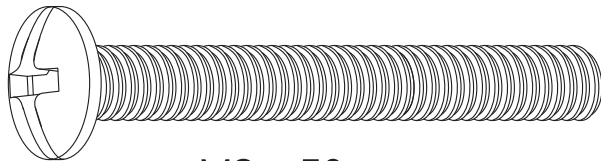

M8 x 50mm
[E3] x 4

Paso 1 Asegure los soportes de la TV a la TV

Seleccione los perno para el TV

Su televisor solo admite uno de los tamaños de perno.

M4



M6



M8

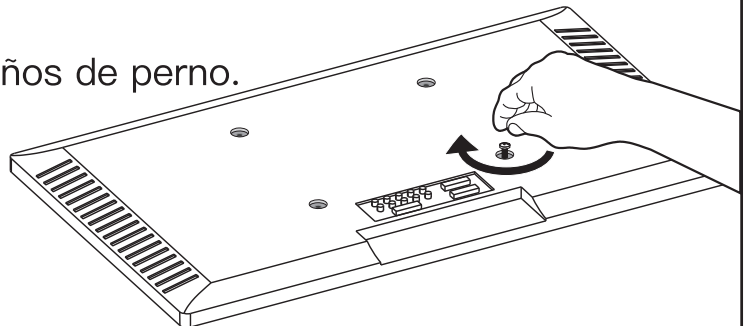

NOTA: No ajuste los pernos del televisor en exceso para no dañarlo.

Longitud del perno: Compruebe que la rosca encaje correctamente con los pernos o la las combinaciones de pernos / espaciador. Se recomienda enganchar las roscas con 5 vueltas como mínimo.

- Si es demasiado corto, no soportará el TV.
- Si es demasiado largo, hará daños al TV.

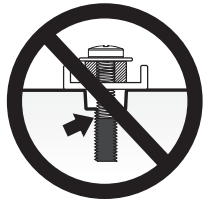

Demasiado corto

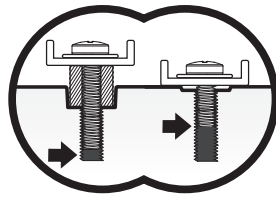

Correcto



Demasiado largo

NOTA: Al utilizar espaciadores, es importante tener en cuenta que se pueden utilizar apilados. Si tiene alguna dificultad para comprender el modo de instalación de los pernos o espaciadores del televisor, póngase en contacto con nuestra línea de asistencia técnica al (877) 419-7832 o con el servicio de atención al cliente en support@ergoav.com.

Piezas necesarias si tiene un televisor como el que se muestra a continuación.

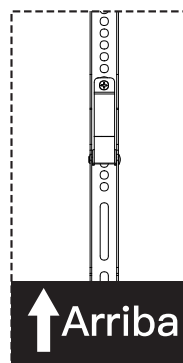
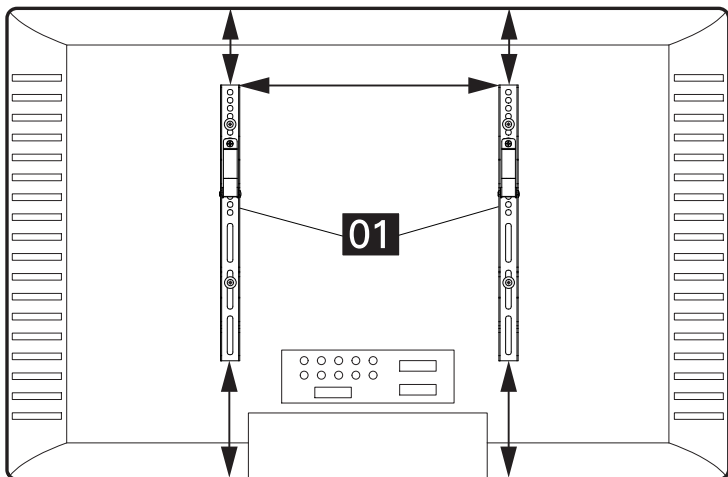
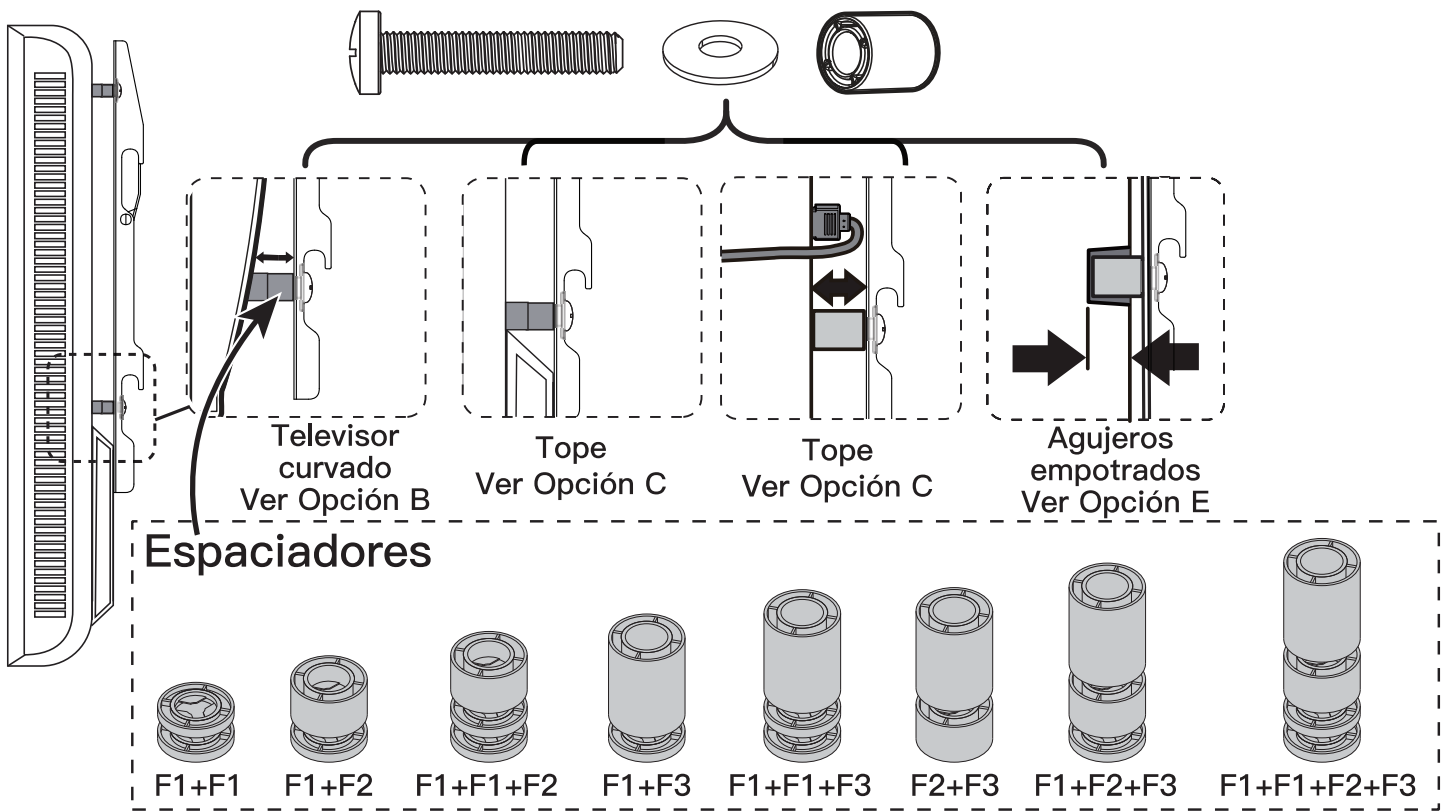

⚠ PRECAUCIÓN: Cuando fije los soportes para TV a la parte posterior del televisor, asegúrese de que las flechas hacia arriba apunten a la parte superior del televisor y estén igualmente centradas en la parte posterior del mismo.

⚠ NOTA: Las ubicaciones de los agujeros para perno de su televisor pueden variar según el diseño del televisor de los fabricantes. Solo ilustramos algunas ubicaciones posibles de dichos agujeros de los pernos.

Opción A (Para televisores con la parte trasera plana)

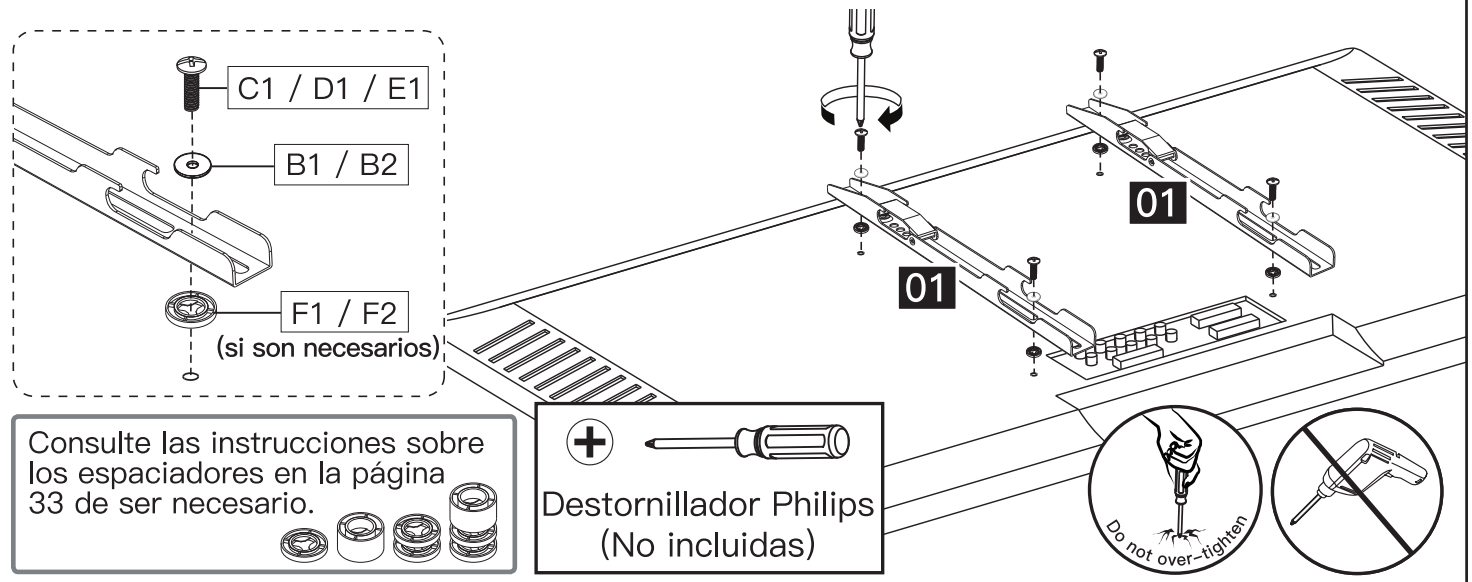

Opción B (para TV con respaldo curvo)

Los espaciadores deben ser lo suficientemente altos para que la curva de la parte posterior del televisor no interfiera con la placa de montaje.

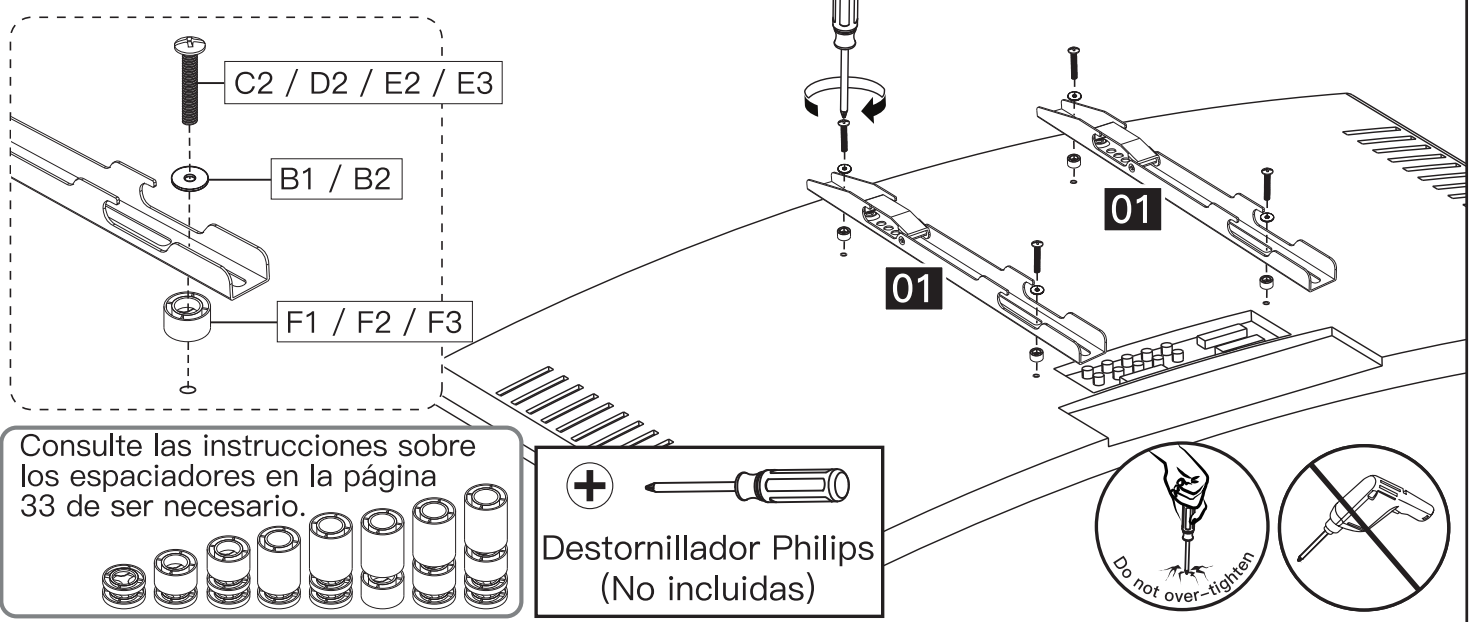

Opción C (Para televisores con parte trasera saliente)

Los espaciadores deben ser lo suficientemente altos como para que los soportes del TV queden al ras (SIN ESPACIO) de los ganchos.

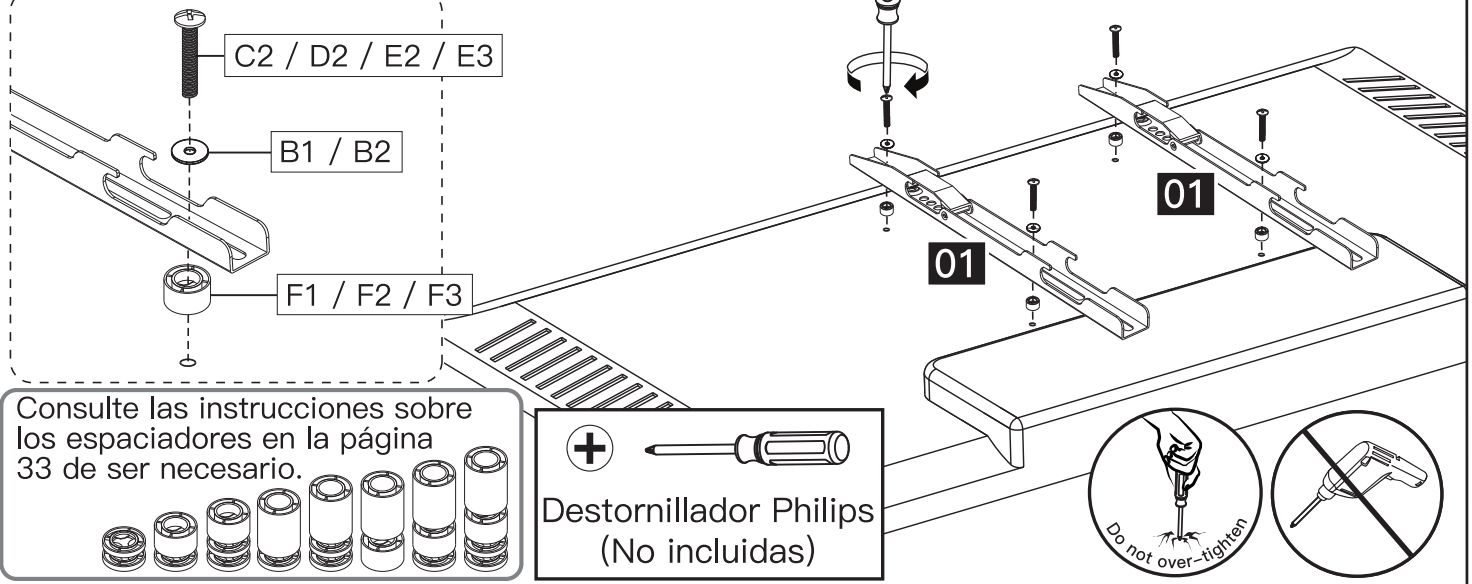

Opción D (para interferencia de cable)

Para la interferencia de cables, utilice los espaciadores para crear un espacio extra entre el televisor y los soportes para TV.

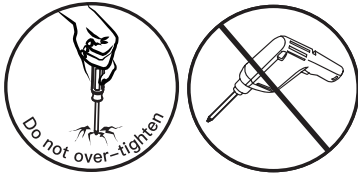

Consulte las instrucciones sobre los espaciadores en la página 33 de ser necesario.

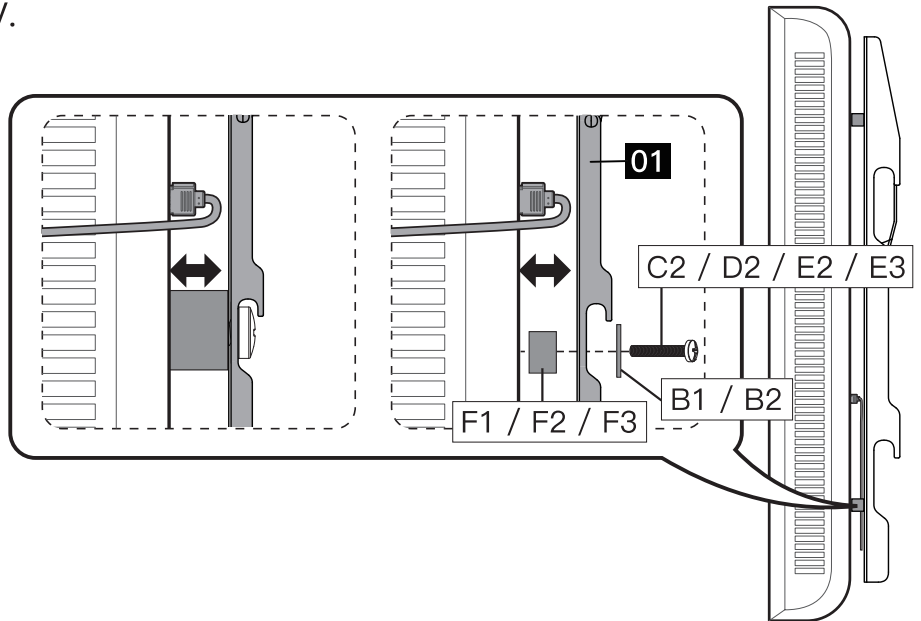

Opción E (Para agujeros empotrados)

El espaciador debe rellenar los agujeros empotrados en la base del televisor para que los soportes para TV estén lo más cerca posible del mismo.

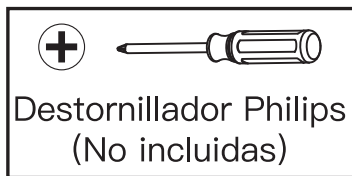
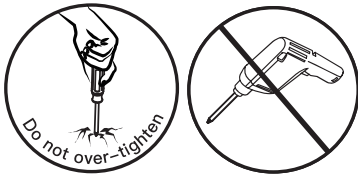

Consulte las instrucciones sobre los espaciadores en la página 33 de ser necesario.

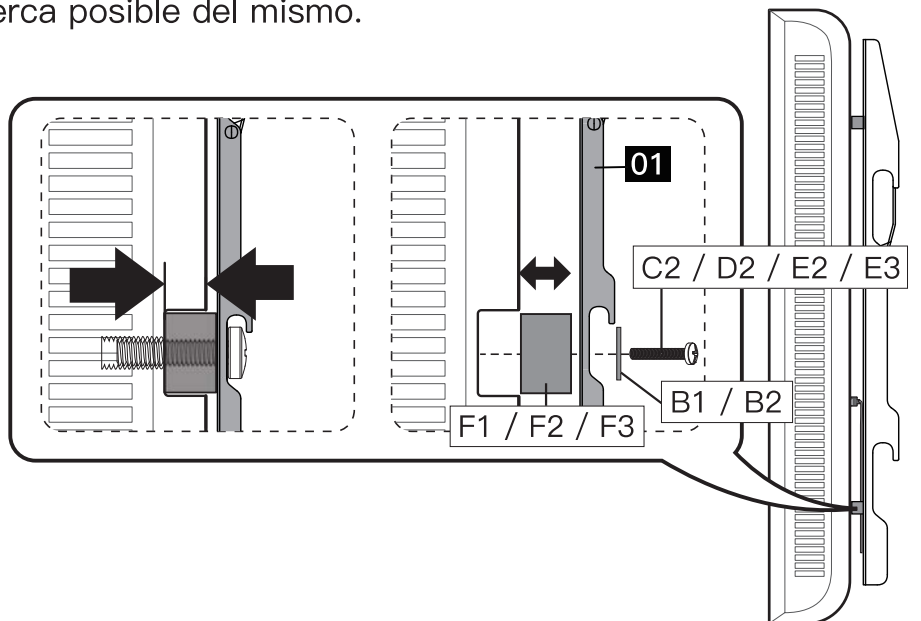

Piezas y herrajes suministrados para el paso 2

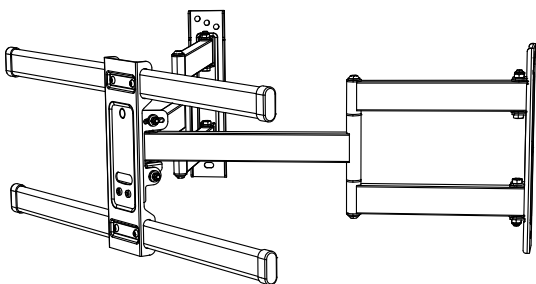

Conjunto de brazo / Placa de pared

02 x 1

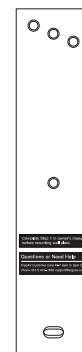

Plantilla de placa de pared **03** x 2

NOTA: El tornillo de retraso se muestra en tamaño real.

A1 x 6

Tornillo de retraso
5/16 pulg x 2 3/4 pulg

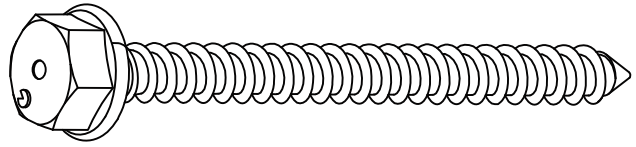

A2 x 6

Anclas de
pared
10 x 60mm

! PRECAUCIÓN!

Este taco es SOLO para
paredes de hormigón. No
los utilice en paredes de
yeso o madera.



Paso 2 Fije el Conjunto de brazo / placa de pared a la pared

Para la instalación en montantes de madera, siga el PASO 2A.

Para la instalación de hormigón, siga el PASO 2B

Paso 2A Opción para montantes de madera

! ADVERTENCIA:

- ¡Evite posibles lesiones o daños a objetos de su propiedad! No ajuste demasiado los tornillos de retraso [A1]. Ajuste los tornillos de retraso [A1] con firmeza contra la placa de pared y la pared.
- No utilice un taladro para ajustar los tornillos de retraso. Utilice únicamente una llave de tubo.
- NO UTILICE EL TACO [A2] PARA ESTE PASO.
- Asegúrese de que la placa de pared esté bien sujeta a la pared antes de continuar con el siguiente paso.
- Tamaño nominal del montante de madera: común 2 x 4 pulg (51 x 102mm).
- Debe revisar el centro del montante.



2A-1

NOTA: Al usar soportes angulares: Encuentre sus ubicaciones para montante y márquelas, luego despliegue el soporte sobre el suelo. Ajustelo según sus ubicaciones para montante antes de instalarlo y asegúrese de que su Televisor entre en la ubicación deseada.

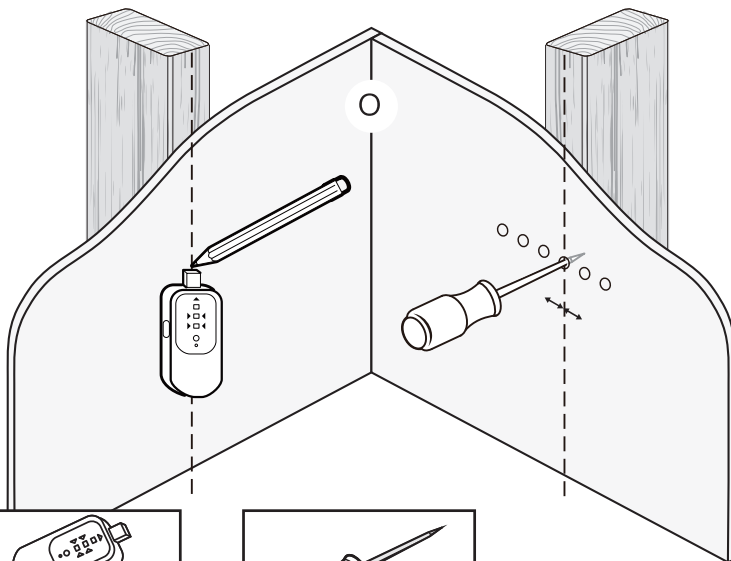

Detector
de vigas
(No Incluidas)

Punzón
(No Incluidas)

Utilice un localizador de montantes para localizar los montantes de madera o utilice un punzón para revisar los bordes. Marque los bordes y el centro.

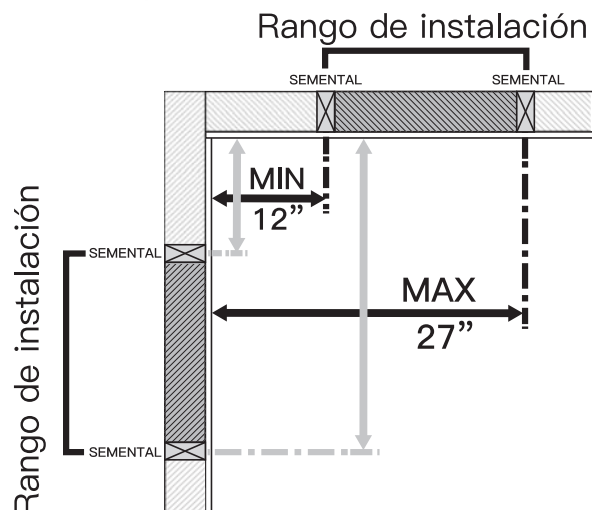

2A-2

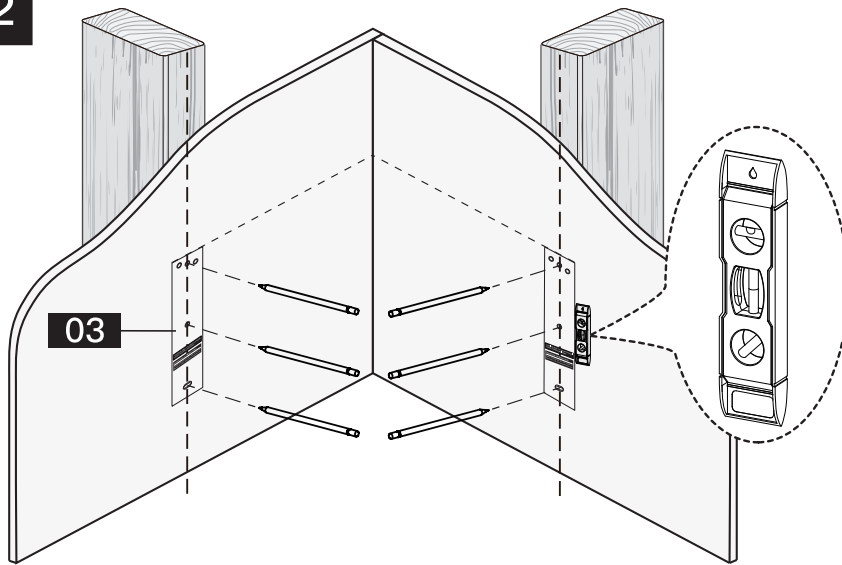

Coloque la plantilla de placa de pared [03] a la altura deseada y alinee los agujeros con la línea central de los montantes. Nivele la plantilla de placa de pared [03] y marque los agujeros.

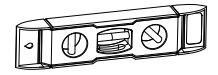

Nivel
(No Incluidas)

2A-3

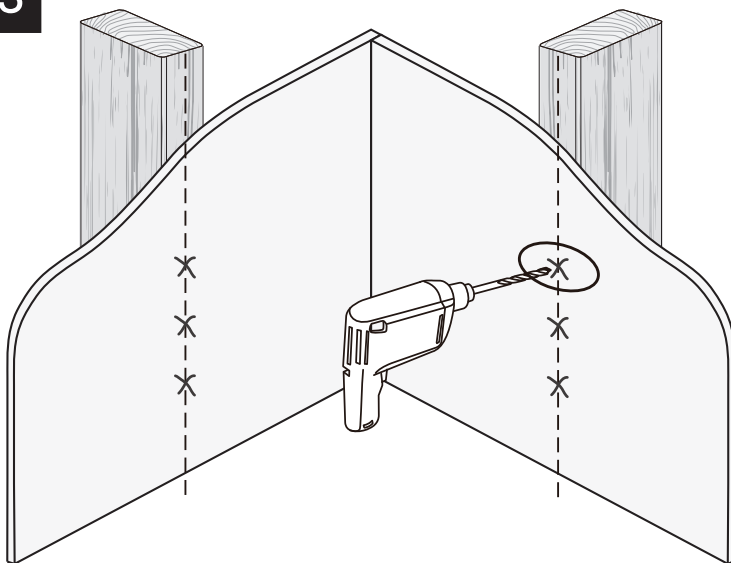

Taladre los agujeros provisorios con una broca de 7/32 pulg (5.5mm) de diámetro. Asegúrese de que la profundidad no sea inferior a 2 3/4 pulg (70mm)

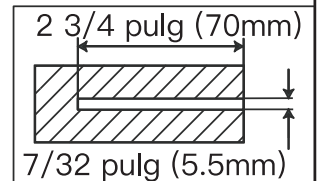

2A-4

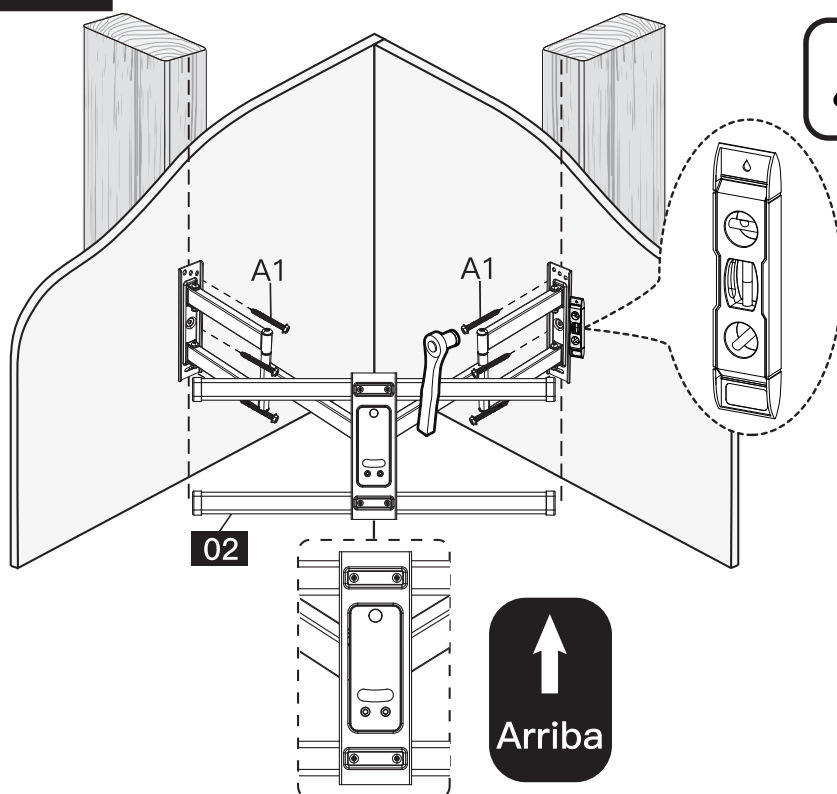

¡OBJETO PESADO! Es posible que necesite asistencia en este paso.

NOTA: No utilice un taladro para ajustar los tornillos de retraso. Utilice únicamente una llave de tubo.

Use 6 tornillos de retraso [A1] para instalar el conjunto de brazo / placa de pared [02]. Ajuste los tornillos de retraso [A1] solo hasta que estén bien contra el placa de pared y la pared.

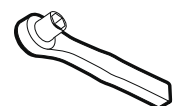
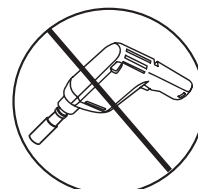

1/2 pulg (13mm)
Llave de tubo
(no incluidas)



Paso 2B Opción de pared de hormigón sólido

⚠ ADVERTENCIA:

- ¡Evite posibles lesiones o daños a objetos de su propiedad! No ajuste demasiado los tornillos de retraso [A1]. Ajuste los tornillos de retraso [A1] con firmeza contra la placa de pared y la pared.
- No utilice un taladro para ajustar los tornillos de retraso. Utilice únicamente una llave de tubo.
- Asegúrese de que la conjunto de brazo / placa de pared [02] esté bien sujeta a la pared antes de continuar con el siguiente paso.
- Monte la conjunto de brazo / placa de pared [02] directamente sobre la superficie de hormigón sin ningún tipo de recubrimiento.
- El grosor de la pared de hormigón debe ser mayor a 5.5 pulg (140mm).



2B-1

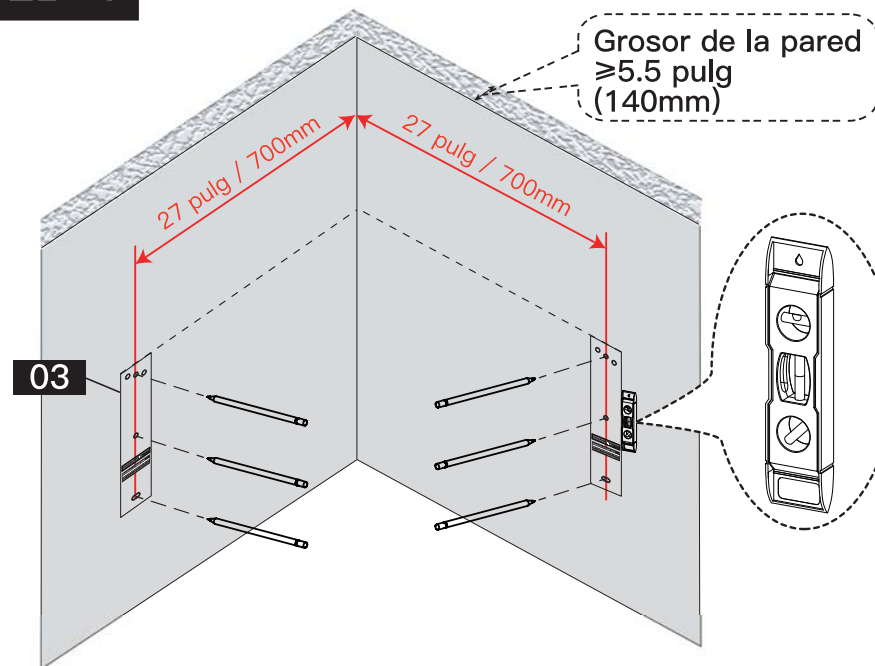

Coloque la plantilla de Placa de Pared [03] a la altura deseada. Nivele la plantilla de placa de pared [03] y marque las ubicaciones para los agujeros pilotos. (la distancia entre el centro y la esquina de la pared debe ser de 27 pulg \approx 700 mm)

2B-2

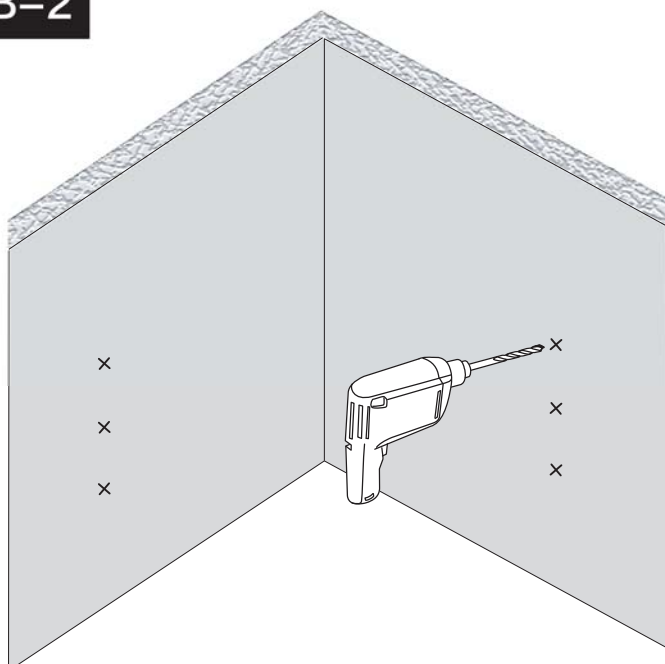

Taladre 6 agujeros piloto con una broca de 3/8 pulg (10 mm) de diámetro. Asegúrese de que la profundidad no sea inferior a 3 pulg (75mm).



Taladro eléctrico
(No Incluidas)

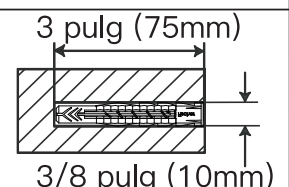

2B-3

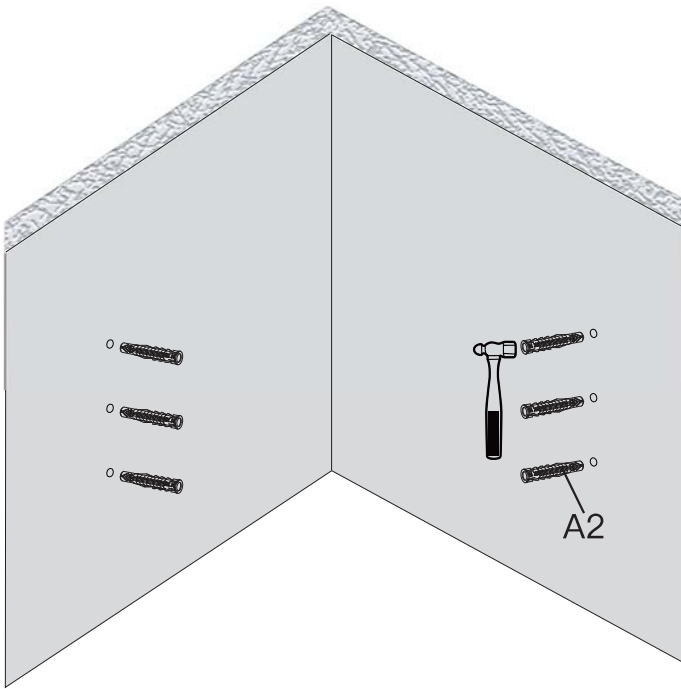

Utilice el martillo para golpear los Anclas de pared [A2] en la pared. Asegúrese de que los Anclas de pared [A2] se asienten a ras de la superficie de hormigón.



Martillo
(No Incluidas)

2B-4

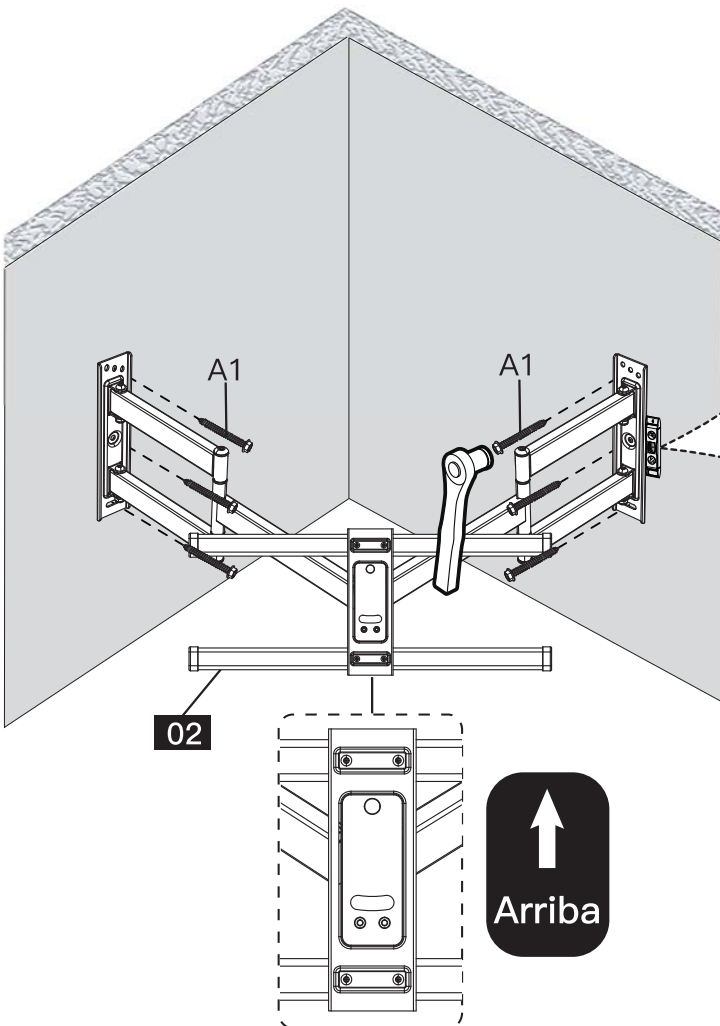

¡OBJETO PESADO! Es posible que necesite asistencia en este paso.

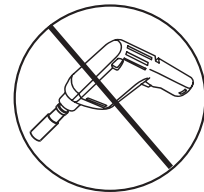

NOTA: No utilice un taladro para ajustar los tornillos de retraso. Utilice únicamente una llave de tubo.

Use 6 tornillos de retraso [A1] para instalar el conjunto de brazo / placa de pared [02]. Ajuste los tornillos de retraso [A1] solo hasta que estén bien contra el placa de pared y la pared.



1/2 pulg (13mm)
Llave de tubo
(no incluidas)

Paso 3 Fije la TV con Soportes al Conjunto de Soporte Frontal

3-1 Retire los Pernos Premontados [S2] de los Soportes de la TV [01] con un destornillador de estrella Phillips autoalimentado. Guarde los Pernos [S2] para utilizarlos en el Paso 3-3.

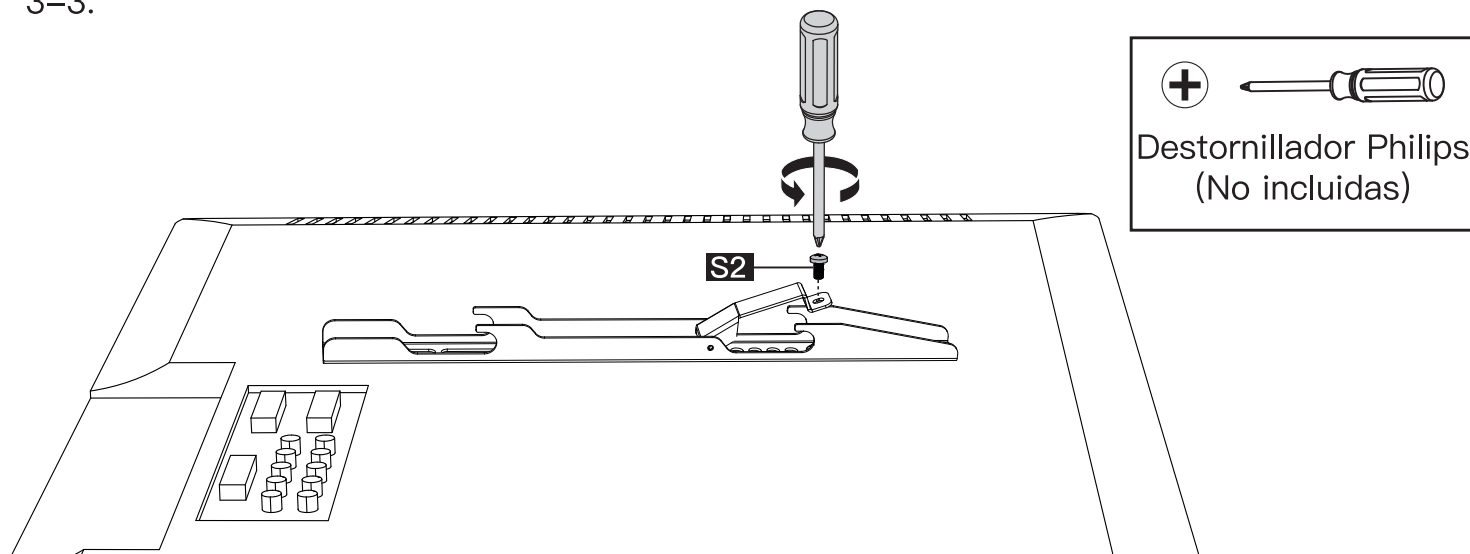

3-2 Antes de intentar colgar la TV, asegúrese de que las Lengüetas de Bloqueo están colocadas hacia la parte inferior de la TV. Cuelgue la TV con los Soportes [01] en el Soporte Frontal. Asegúrese de que los ganchos superior e inferior de los Soportes de la TV [01] estén sobre las Barras del Soporte Frontal.

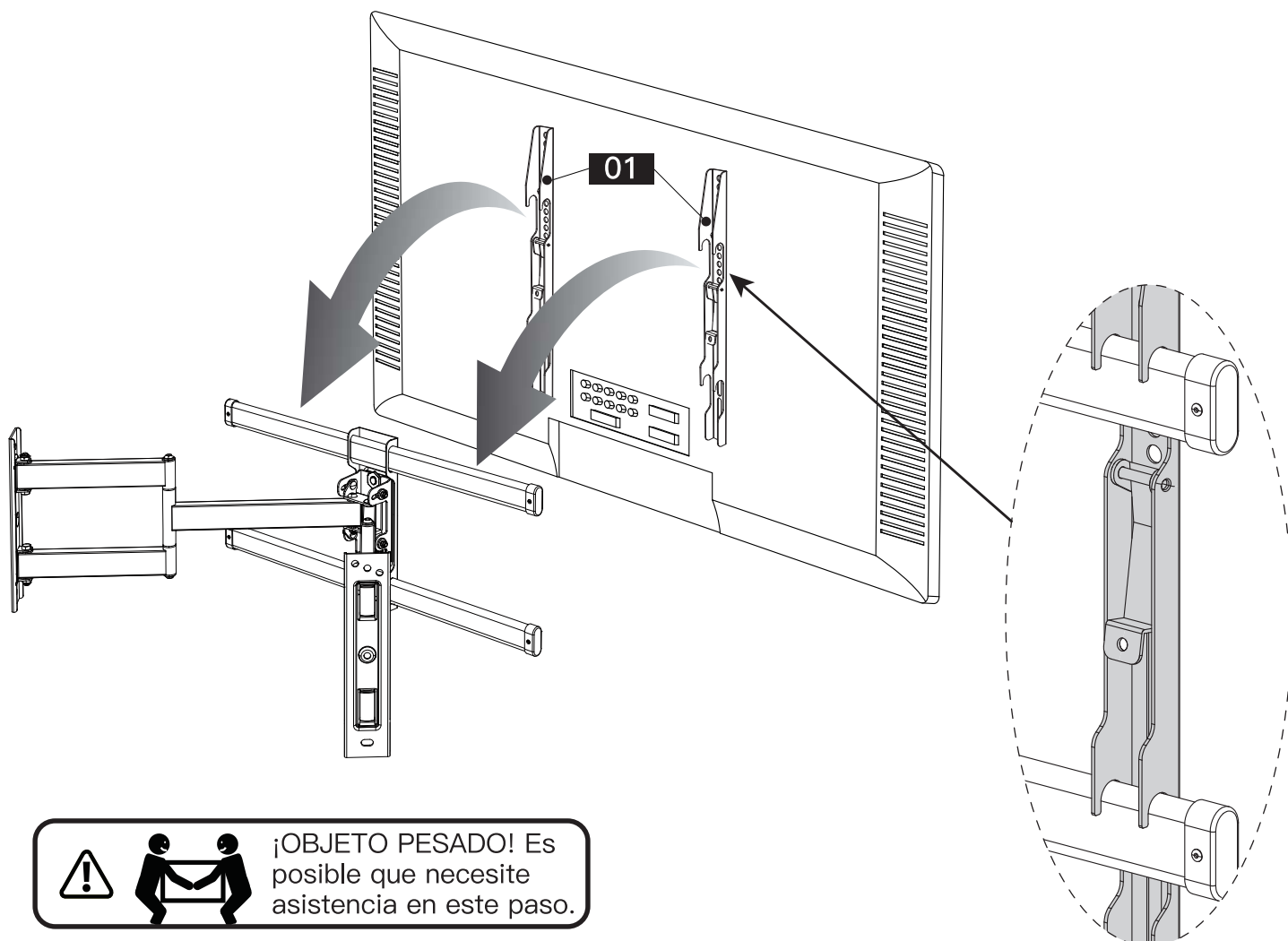

3-3 Coloque las Lengüetas de Bloqueo hacia la parte superior de la TV y fije las Lengüetas de Bloqueo en su lugar utilizando los Pernos [S2] del Paso 3-1. Apriete firmemente los Pernos [S2].

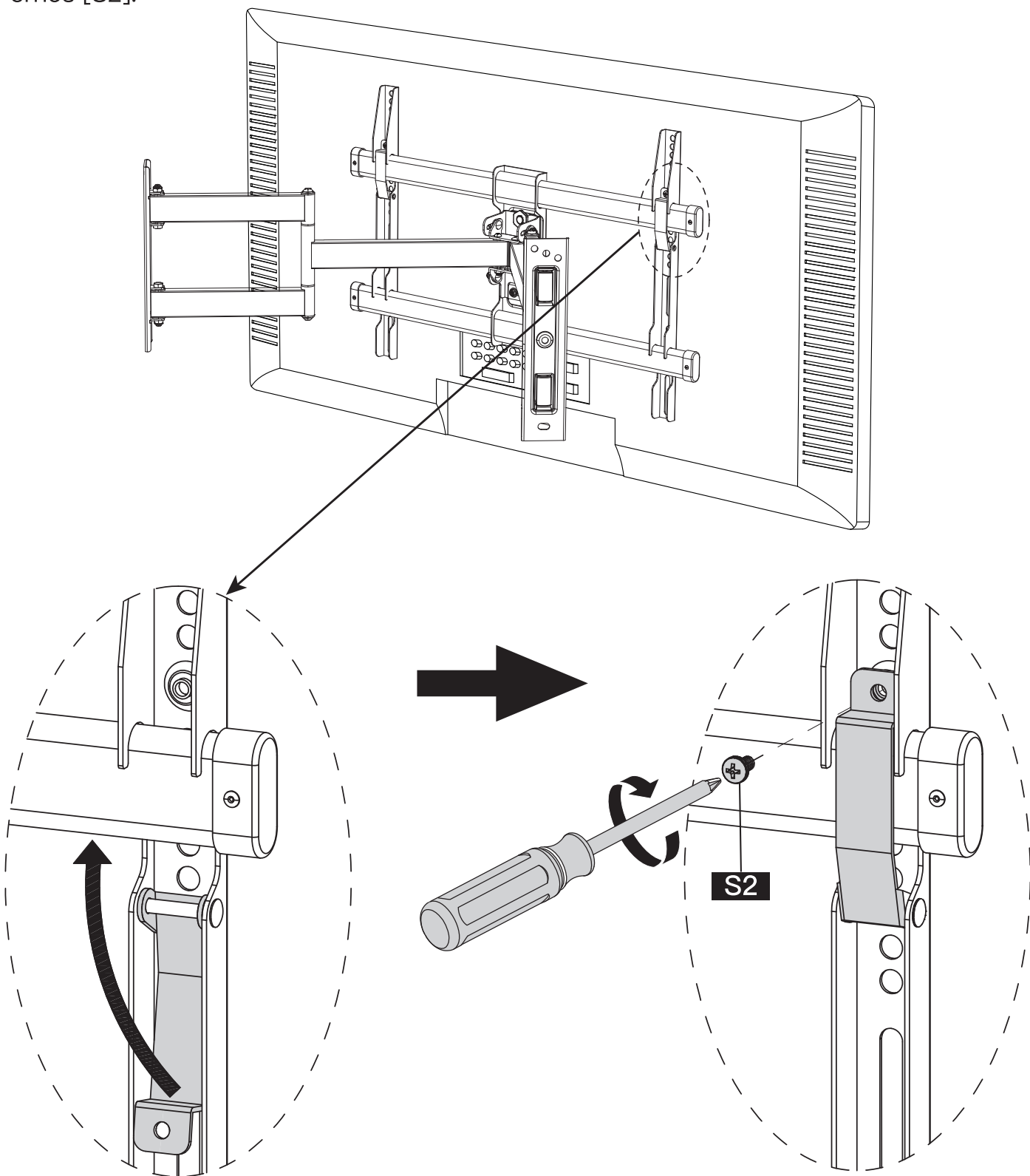

 ¡OBJETO PESADO! Es posible que necesite asistencia en este paso.

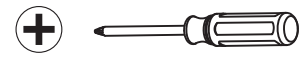
Destornillador Philips (No incluidas)

Paso 4 Modificaciones

Ajuste de la inclinación

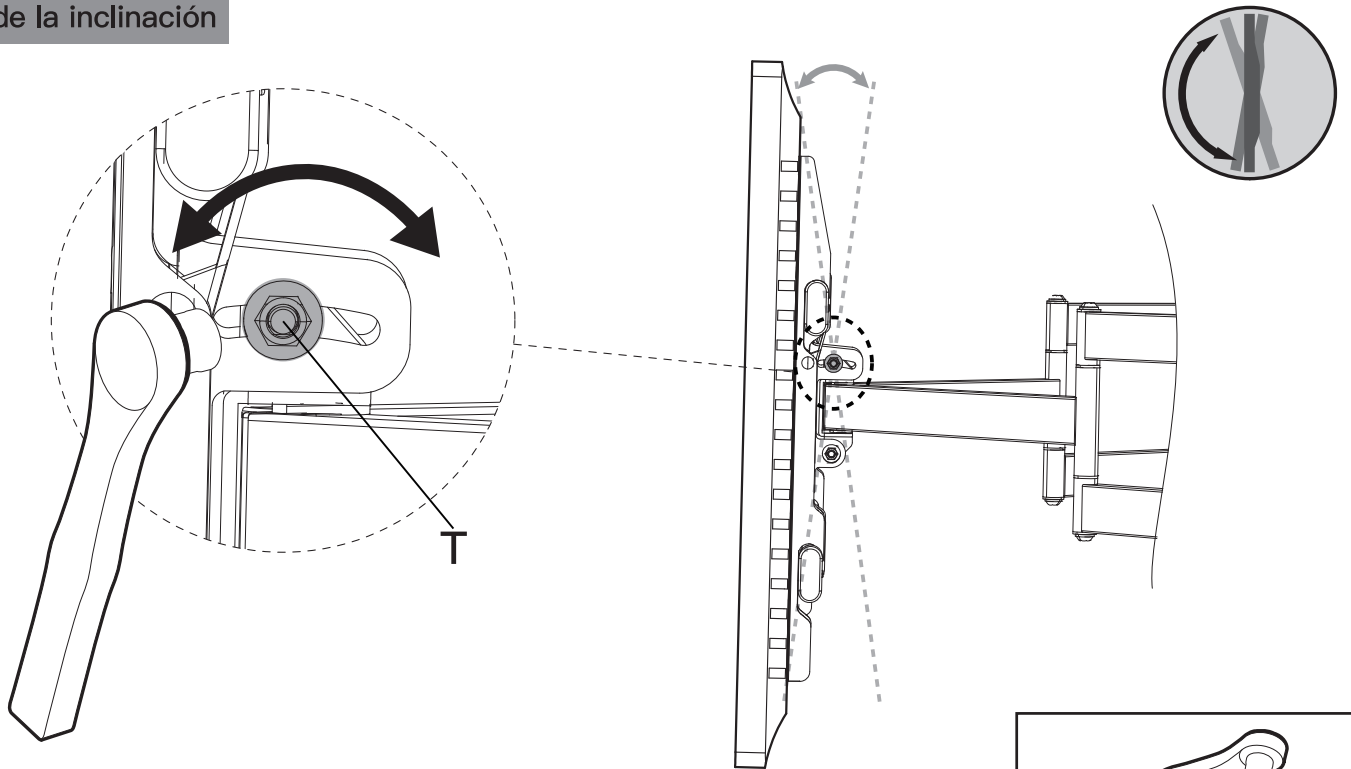

1. Afloje ligeramente las dos tuercas basculantes [T] con una llave de tubo.
2. Ajuste la TV al ángulo de inclinación que desee.
3. Vuelva a apretar las dos tuercas de inclinación [T] con la llave de tubo para asegurar la TV en su lugar.



3/8 pulg (10mm)
Llave de tubo
(no incluidas)

Ajuste de nivel

Puede nivelar el Televisor de ser necesario.

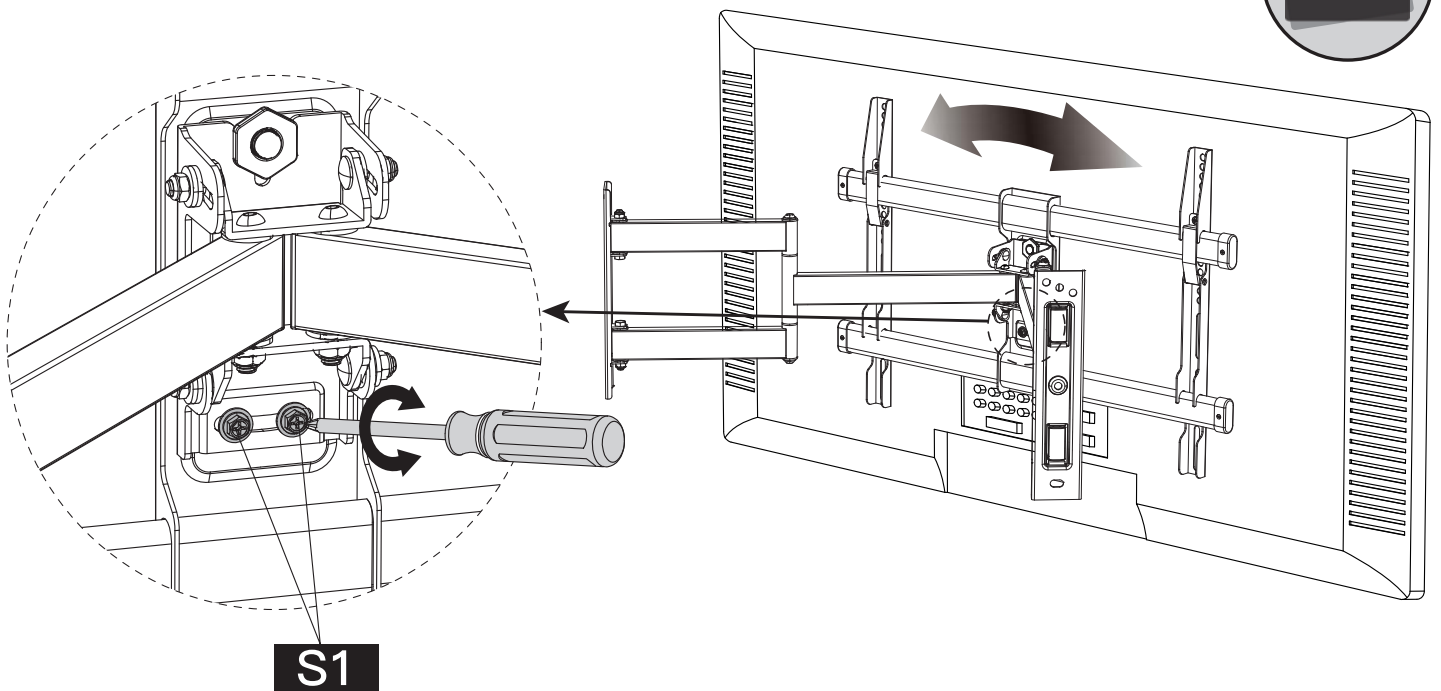

1. Afloje ligeramente los dos pernos [S1] de la parte trasera del soporte frontal.
2. Nivele el televisor.
3. Vuelva a apretar los dos tornillos [S1] para sujetar la TV en su sitio.

+

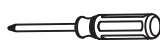

Destornillador
Philips
(No incluidas)

Ajuste del giro

Ubicación del medio

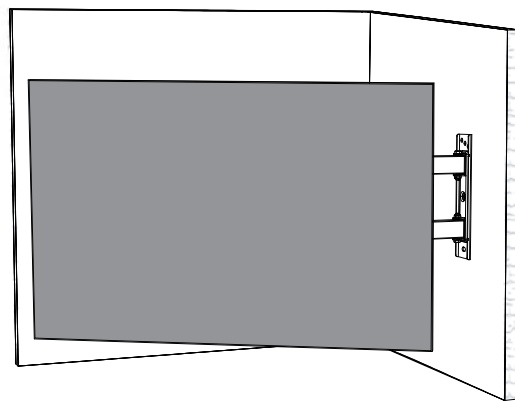
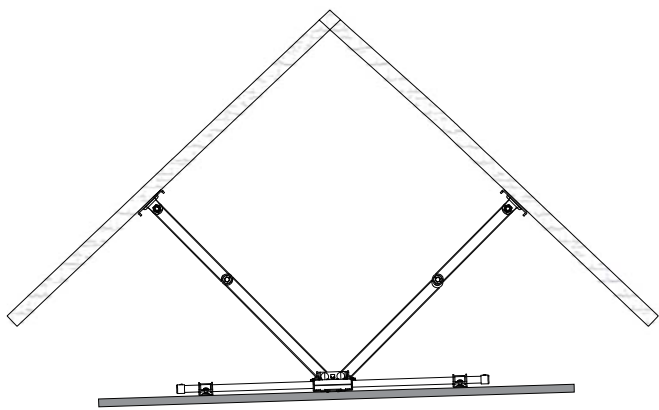

Giro de lado izquierdo

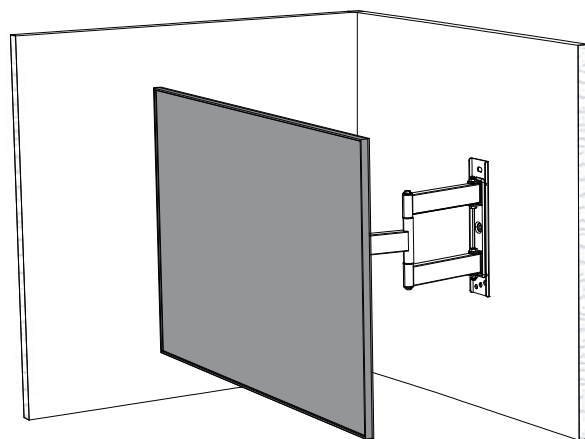
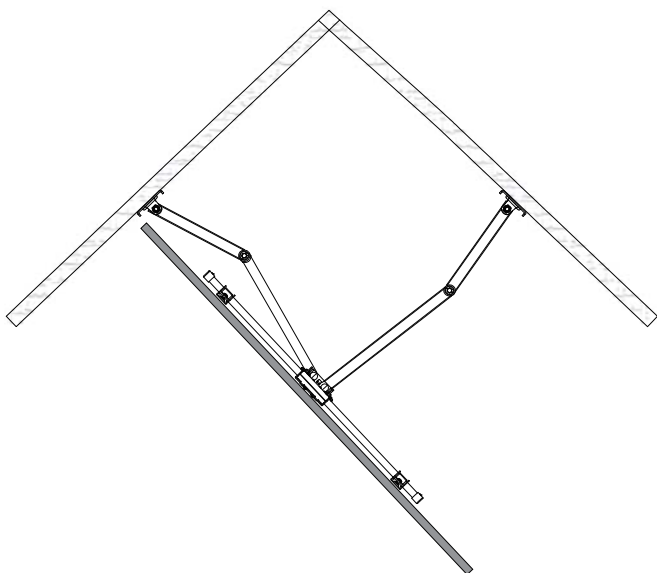

Giro de lado derecho

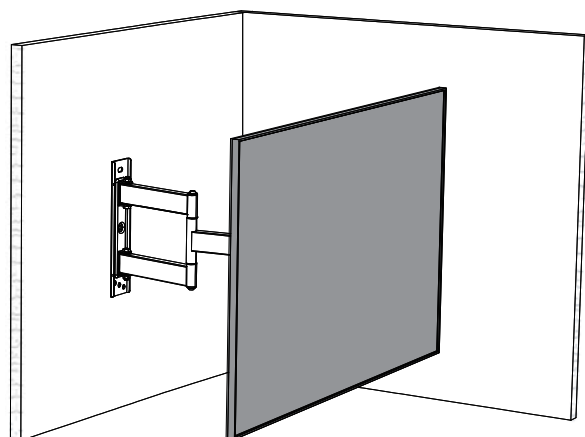
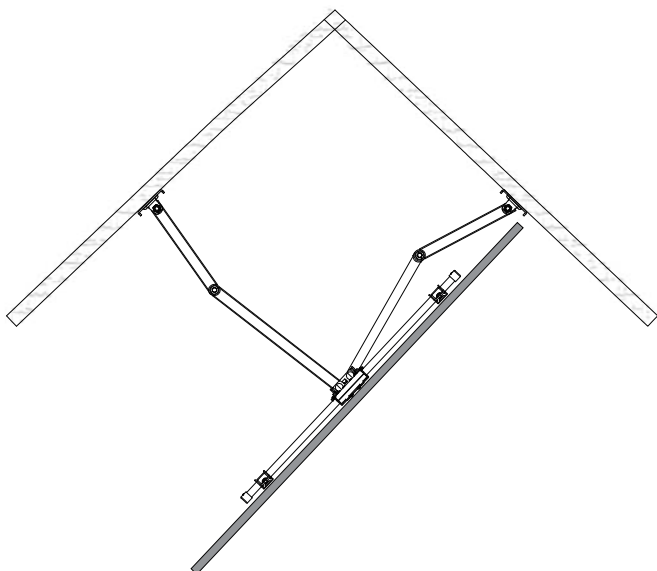



At ErgoAV, we strive to provide the highest value products.
We want to support your purchase.
If you have questions, concerns,
or feedback please let us know!

ErgoAV Customer Care
Phone (877) 419-7832
support@ergoav.com

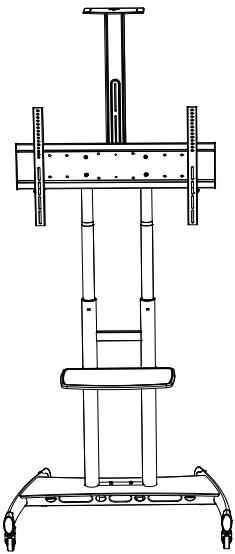

TV Carts

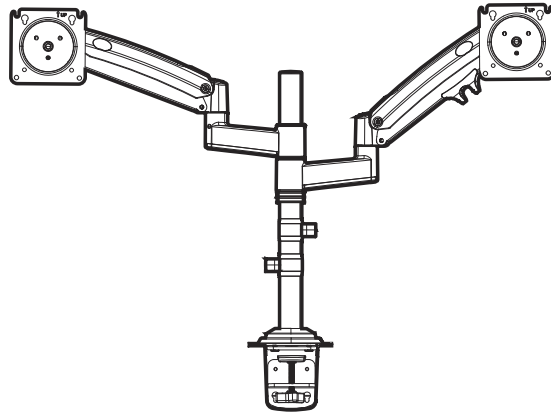

Computer Monitor Mounts

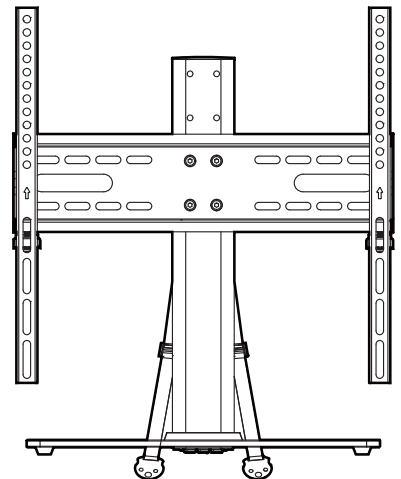

Tabletop TV Stands

9501 Louisiana Ave N, #200, Brooklyn Park, MN 55445
www.ergoav.com