



# Motion TV Mount Instruction Manual

(A)

English pages: 02–15

French pages: 16–29

Spanish pages: 30–43

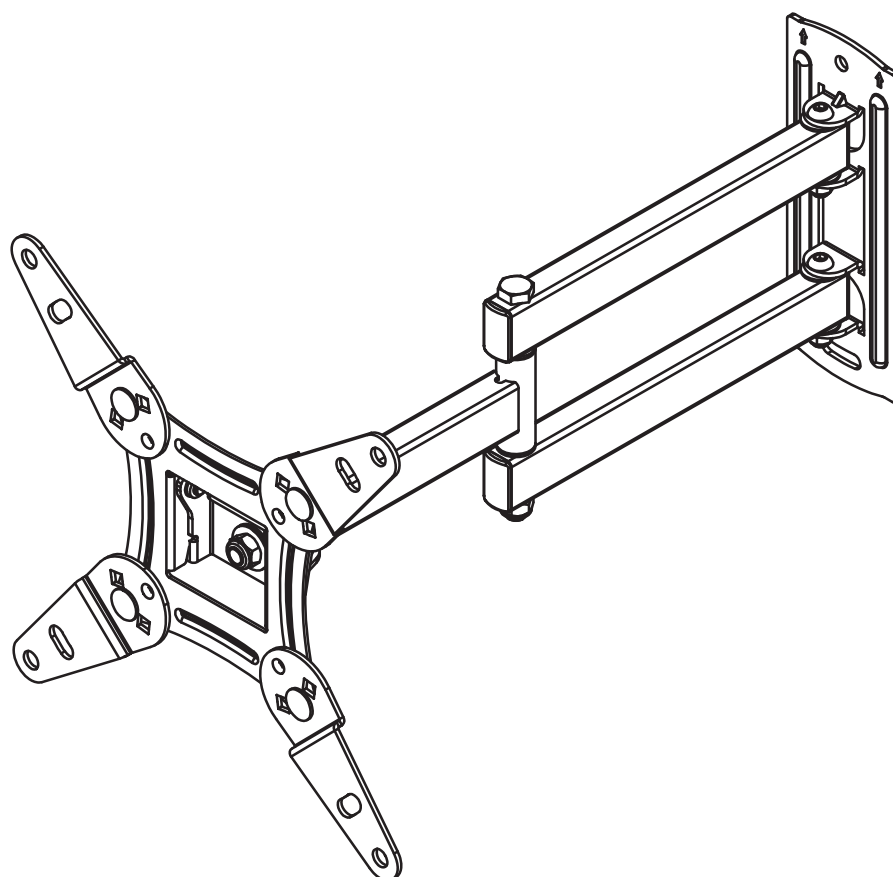

**Model: ERMMS1-01B**

**THANK YOU FOR CHOOSING THIS ERGOAV PRODUCT!**

At ErgoAV, we want to add value to your AV experience by providing the highest quality products and services in the industry. If you have any concerns or comments, please contact us.

ErgoAV Customer Care  
phone (877) 419-7832

email: [support@ergoav.com](mailto:support@ergoav.com)

website: [www.ergoav.com](http://www.ergoav.com)

address: 9501 Louisiana Ave N, #200, Brooklyn Park, MN 55445

## IMPORTANT SAFETY INFORMATION

**⚠ DANGER!** Please carefully read all instructions before attempting installation. If you do not understand the instructions or have any concerns or questions, please contact our Technical Support line at (877) 419-7832 or customer service at [support@ergoav.com](mailto:support@ergoav.com).

**⚠ CAUTION:** Use with products heavier than the maximum weights indicated may result in instability causing possible injury.

- Do not use this product for any purpose that is not explicitly specified in this manual. Do not exceed weight capacity. We are not liable for damage or injury caused by improper mounting, incorrect assembly or inappropriate use.
- This product is designed for use in wood stud, and solid concrete walls. – DO NOT install into drywall alone.
- The wall must be capable of supporting four times the weight of the TV and mount combined.
- Use this mounting system only for its intended use as described in these instructions. Do not use attachments not recommended by the manufacturer.
- Do not use outdoors.
- Route cords and cables properly to avoid mechanical damage.
- SAVE THESE INSTRUCTIONS

## Weight Restrictions



If your TV weighs more, do not use this product.

### **⚠ WARNING**

DO NOT exceed the maximum weight indicated. This mounting system is intended for use only within the maximum weights indicated. Use with products heavier than the maximum weights indicated may result in failure of the mount and its accessories, causing damage and or injury.

## Check the VESA Pattern of Your TV before the Installation

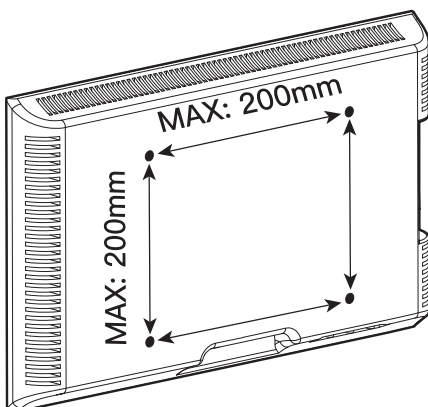

75 mm ≈ 3 in  
100 mm ≈ 4 in  
200 mm ≈ 7 7/8 in

Minimum: 75mm x 75mm / 3" x 3" (W x H)

Maximum: 200mm x 200mm / 7 7/8" x 7 7/8" (W x H)

If your TV's VESA Pattern is smaller than 75mm x 75mm or greater than 200mm x 200mm, this mount is NOT COMPATIBLE with your TV. Please contact our Technical Support at (877) 419-7832 or [support@ergoav.com](mailto:support@ergoav.com) to find a compatible mount.

## Tools Needed (Not Included)



Stud Finder



Awl



Tape Measure



Pencil

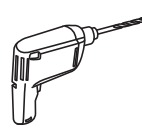

Electric Drill

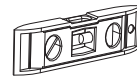

Level



Phillips  
Screwdriver



7/32in(5.5mm)  
Wood Drill



3/8in(10mm)  
Socket Wrench



1/2in(13mm)  
Socket Wrench

(Needed for concrete installs)



3/8in(10mm)  
Concrete Drill



Hammer

## Verify Your Wall Construction

**CAUTION**

DO NOT  
install into  
drywall alone

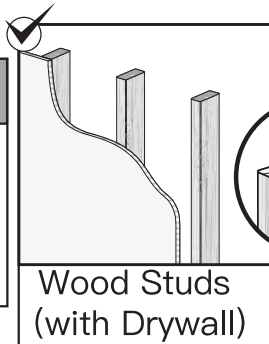

Wood Studs  
(with Drywall)

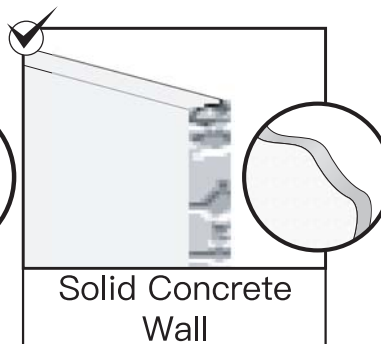

Solid Concrete  
Wall

If you are not sure of the wall construction, please contact our Technical Support line at (877) 419-7832 or customer service at [support@ergoav.com](mailto:support@ergoav.com).

## Supplied Parts and Hardware

**WARNING:** This product contains small items that could be a choking hazard if swallowed.

Before starting assembly, verify all parts are included and undamaged. Do not use damaged or defective parts. If you require replacement parts, please contact our Technical Support line at (877) 419-7832 or customer service at [support@ergoav.com](mailto:support@ergoav.com) to find a compatible mount.

- **PLEASE NOTE:** Not all hardware included in this package will be used.

## Supplied Parts and Hardware for Step 1

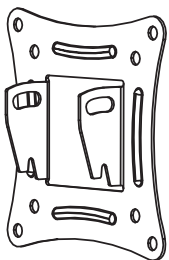

**01** x1  
Faceplate

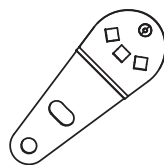

**02** x4  
Extender Bracket

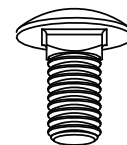

Bolt  
M6 x 12mm  
[H1] X4

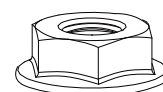

Nut  
M6  
[H2] X4

# Step1 Choose the Combination that Fits Your VESA Hole Pattern

Option A: NO need to attach the extender brackets to faceplate. Skip to Page 06

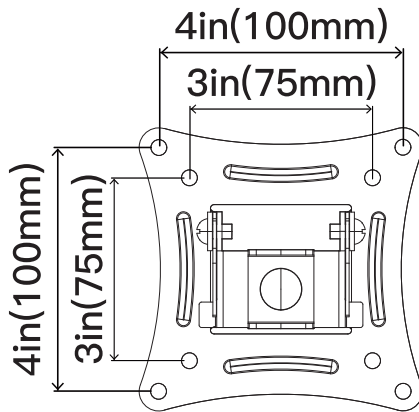

For VESA hole pattern:  
3 x 3in/75 x 75mm  
4 x 4in/100 x 100mm

Option B: Need to attach the extender brackets to faceplate. See Fig. 1 to Fig. 3

## NOTE:

The small bump on the extender bracket [02] should be aligned with the hole on the faceplate [01].

Please do not firmly tighten the bolts [H1] and nuts [H2] until the step 2 is finished.

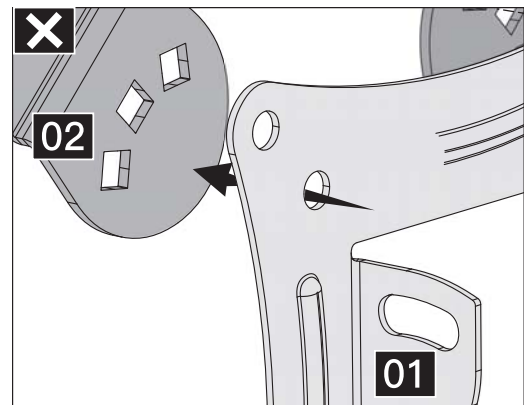
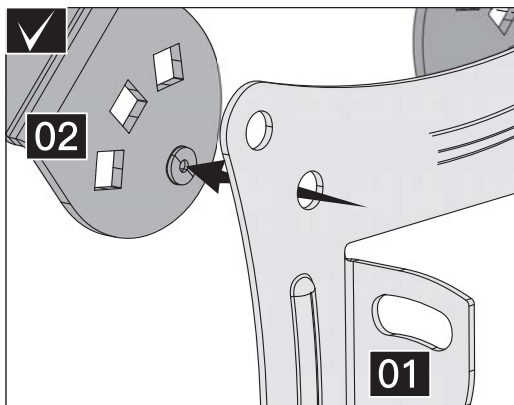
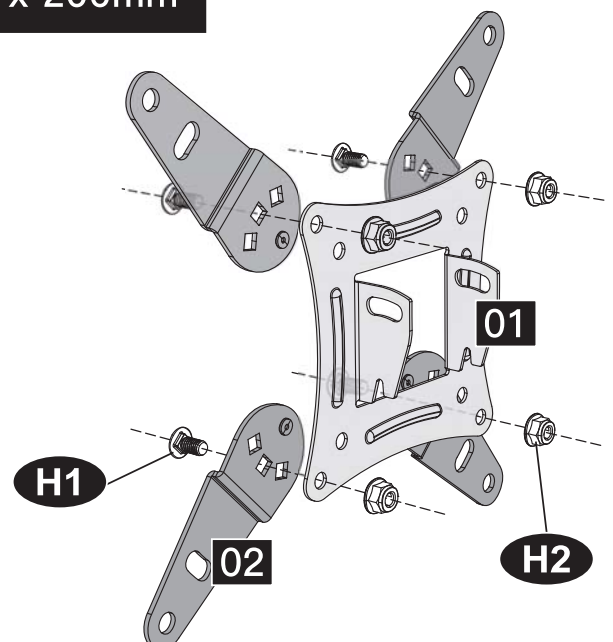
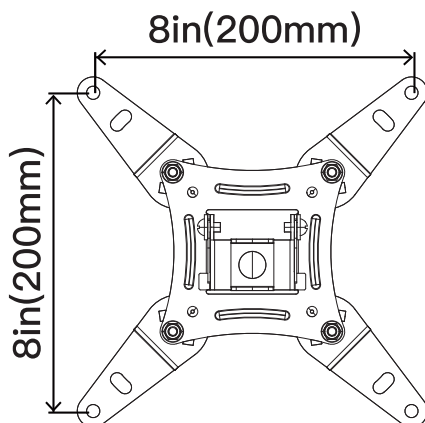
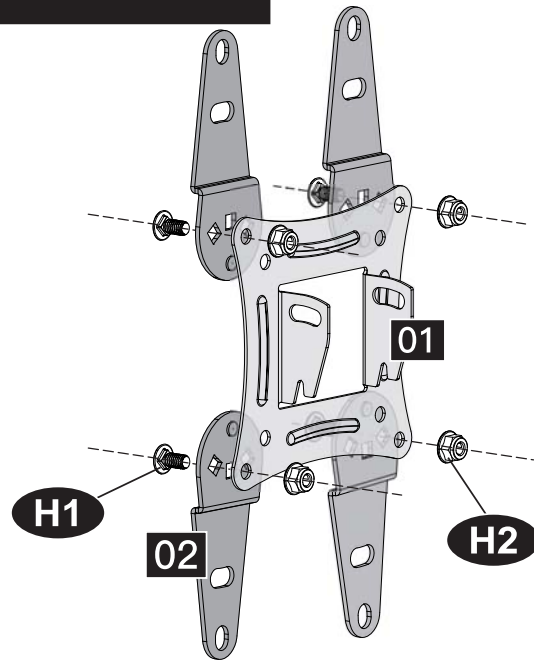
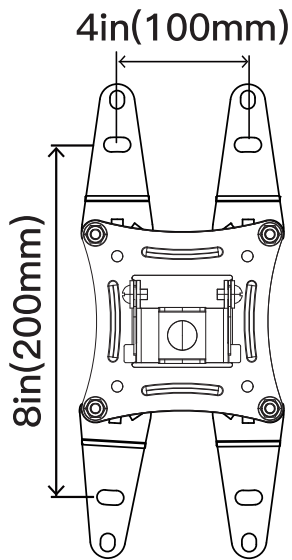

Fig. 1 For VESA Hole Pattern: 8 x 8in/200 x 200mm



**Fig. 2 For VESA Hole Pattern: 4 x 8in/100 x 200mm**



**Fig. 3 For VESA Hole Pattern: 8 x 4in/200 x 100mm**

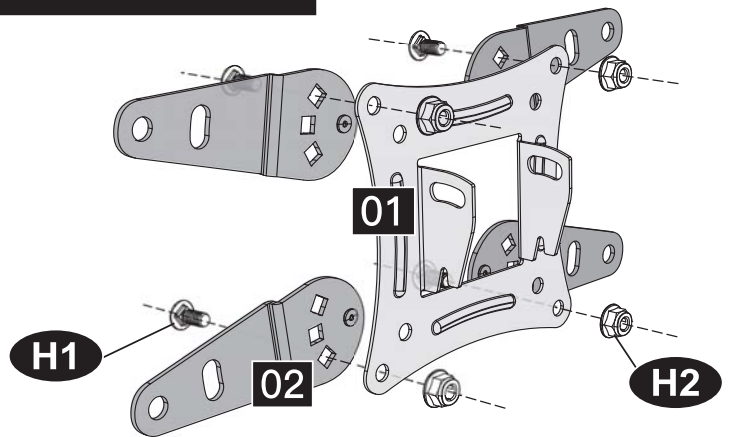
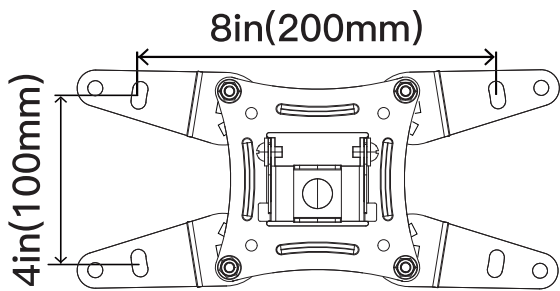

**Supplied Hardware for Step 2**

**04 Washers**

**05 Spacers [If needed]**

**NOTE:** The washers and spacers are shown in actual size

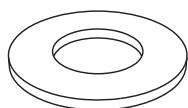
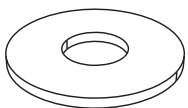

[B1] x4  
M4/M5

[B2] x4  
M6/M8



[G1] x4  
8.5x18x2.5mm

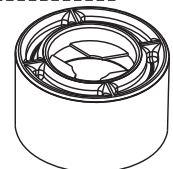

[G2] x8  
8.5x18x10mm

**06 TV Bolts** [Only one bolt size fits your TV]

**NOTE:** The bolts are shown in the actual size

**M4**

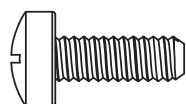

M4 x 12mm  
[C1] x4



M4 x 30mm  
[C2] x4

**M5**

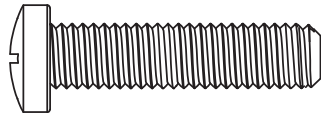

M5 x 25mm  
[D] x4

**M6**

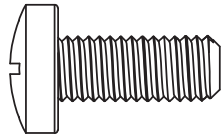

M6 x 15mm  
[E1] x4

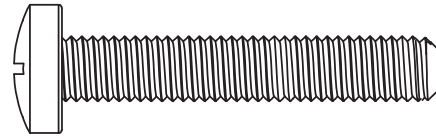

M6 x 35mm  
[E2] x4

**M8**

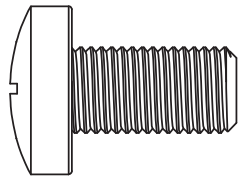

M8 x 15mm  
[F1] x4

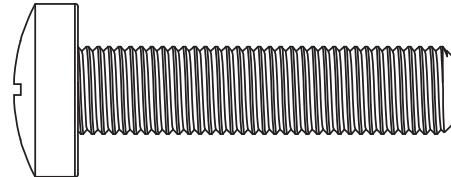

M8 x 35mm  
[F2] x4

## Step 2 Secure the TV Brackets to the TV

### Select TV Bolts

Only one bolt size fits your TV.

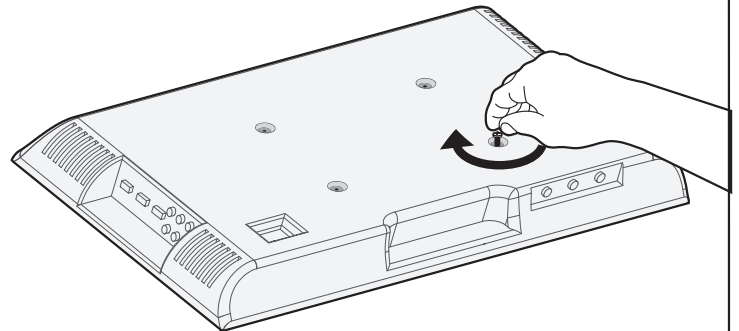
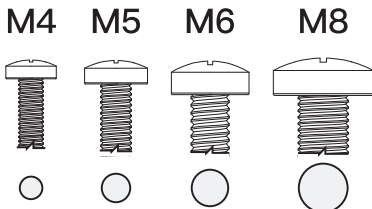

**NOTE:** Please do not over tighten the TV bolts to avoid damaging your TV.

Bolt length: Verify adequate thread engagement with bolts or bolts/spacers combination. We recommend thread engagement by at least 5 turns.

-Too short will not hold the TV.

-Too long will damage the TV.

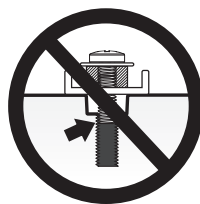

Too Short

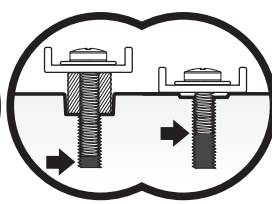

Correct



Too Long

**PLEASE NOTE:** When using the spacers it is important to note that they can be used in multi-layers (meaning stacked). If you have any difficulty understanding how to install the TV bolts or spacers, please contact our Technical Support line at (877) 419-7832 or customer service at [support@ergoav.com](mailto:support@ergoav.com).

# Parts Needed if You Have a TV as Shown Below

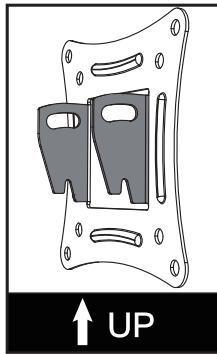
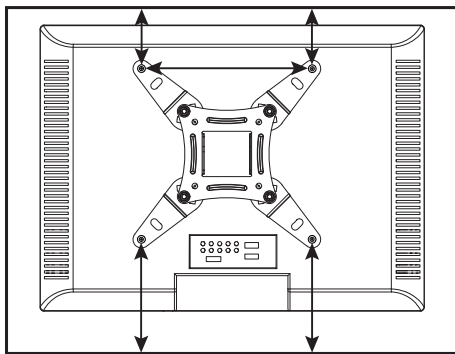
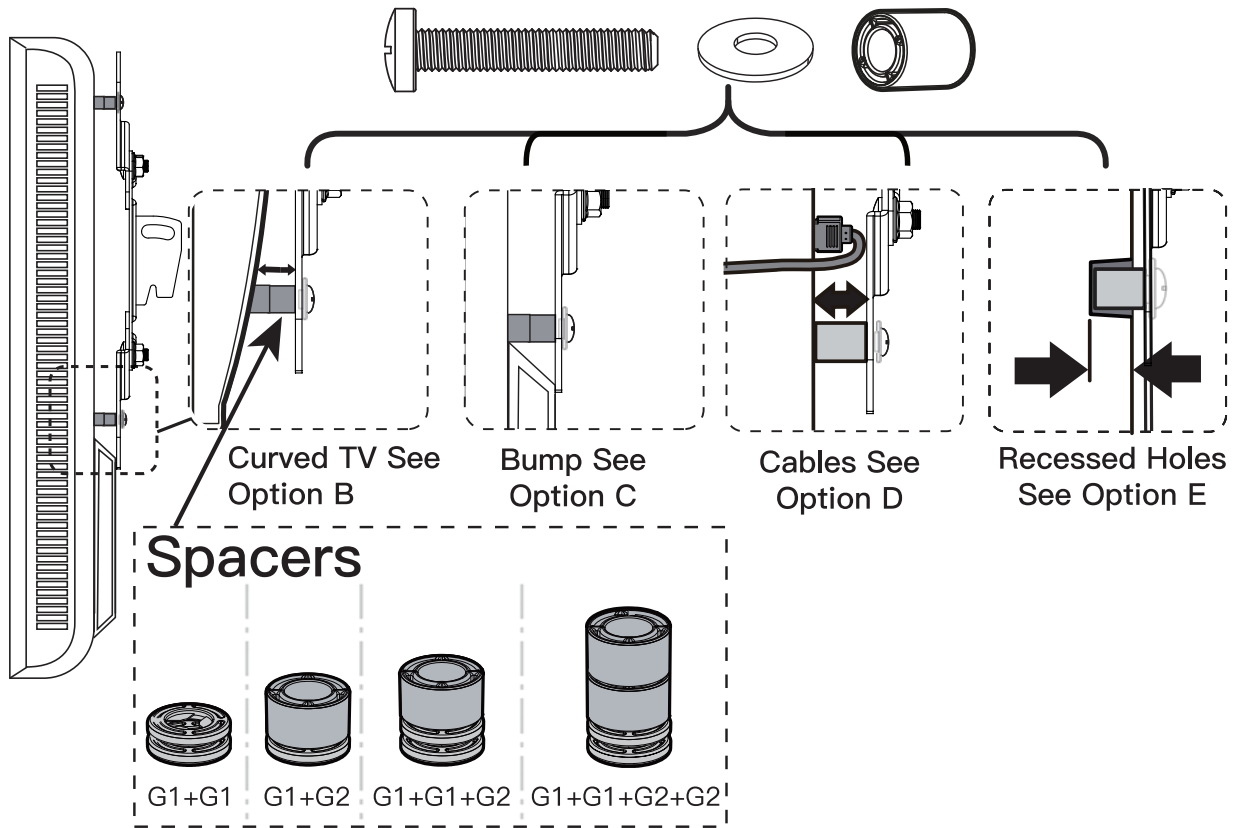

⚠ When attaching the faceplate to the back of the TV, ensure the down-facing hooks are pointing to the bottom of the TV and the faceplate is equally centered on the back of the TV.

⚠ **PLEASE NOTE:** The bolt hole locations on your TV may vary in accordance with the manufacturer's design of the TV. We are only illustrating possible locations of the bolt holes.

## Option A (For Flat Back TV)

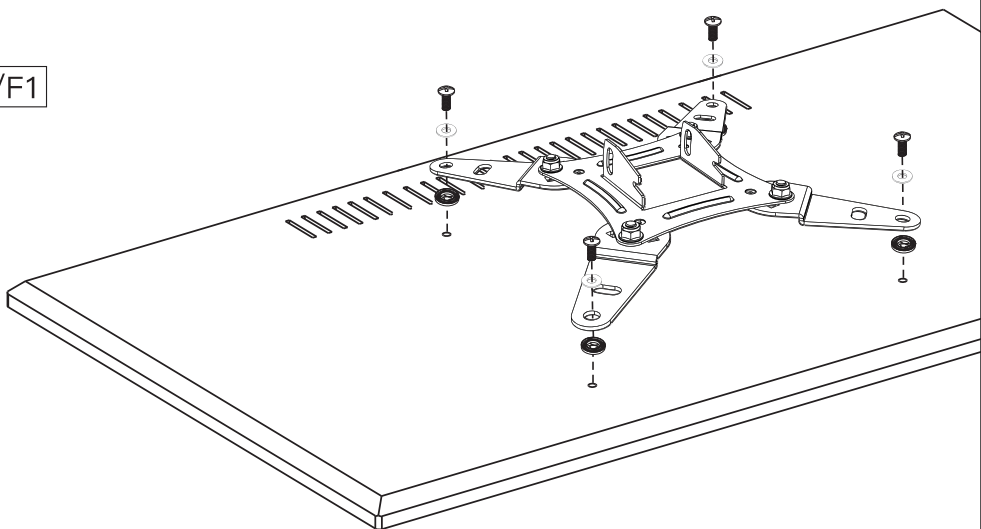
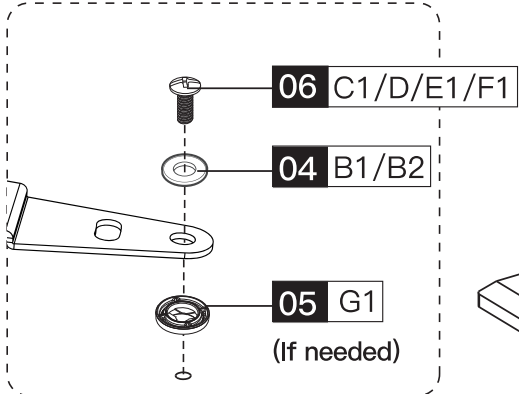

### Option B (For Curved Back TV)

Spacers must be tall enough so that the curve on the back of the TV will not interfere with the mounting plate.

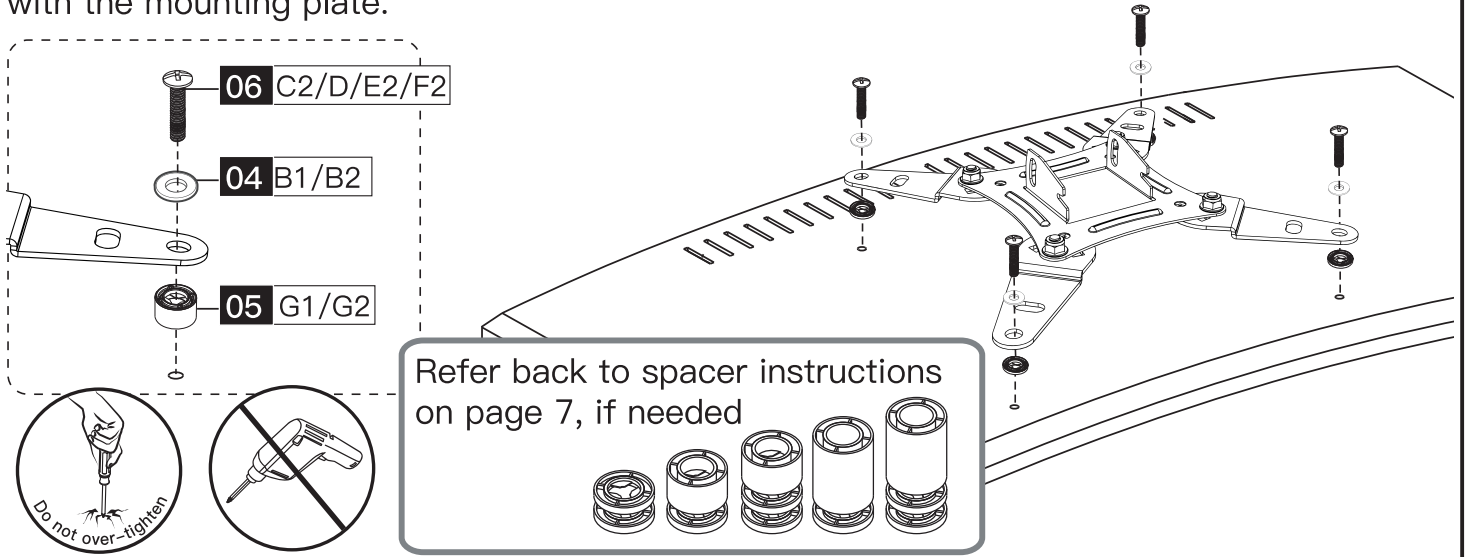

### Option C (For TV with A "Bump")

Spacers must be tall enough so there is no gap between faceplate and bump on the back of the TV.

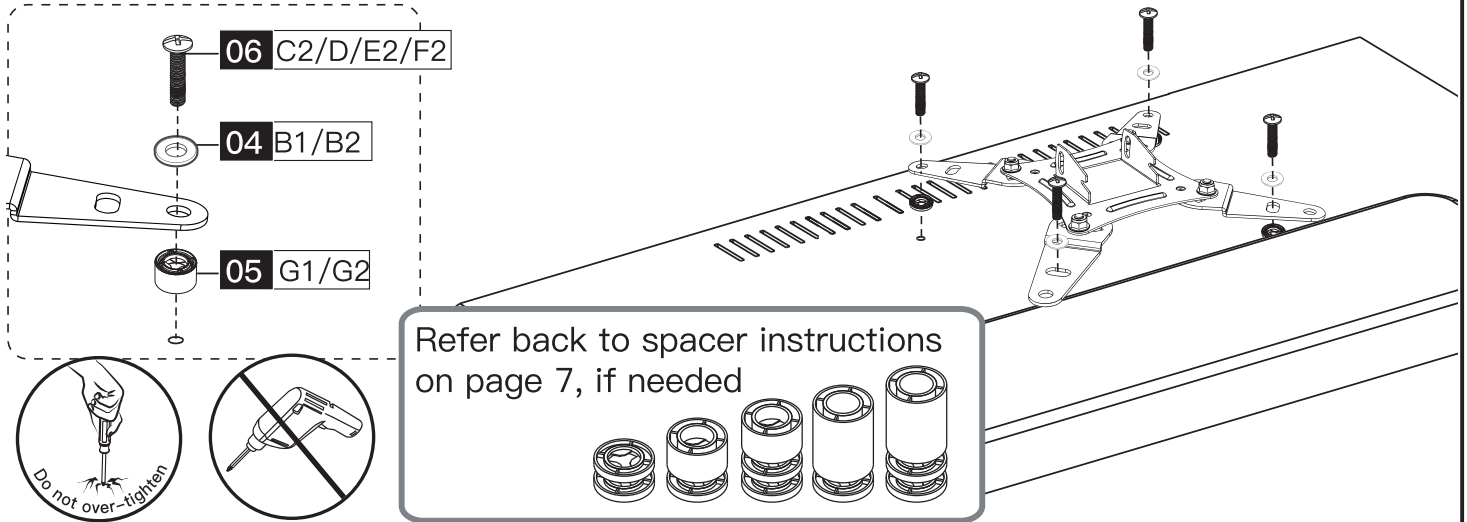

### Option D (For Cable Interference)

For cable interference, use spacers 05 to create extra space between the TV and faceplate.

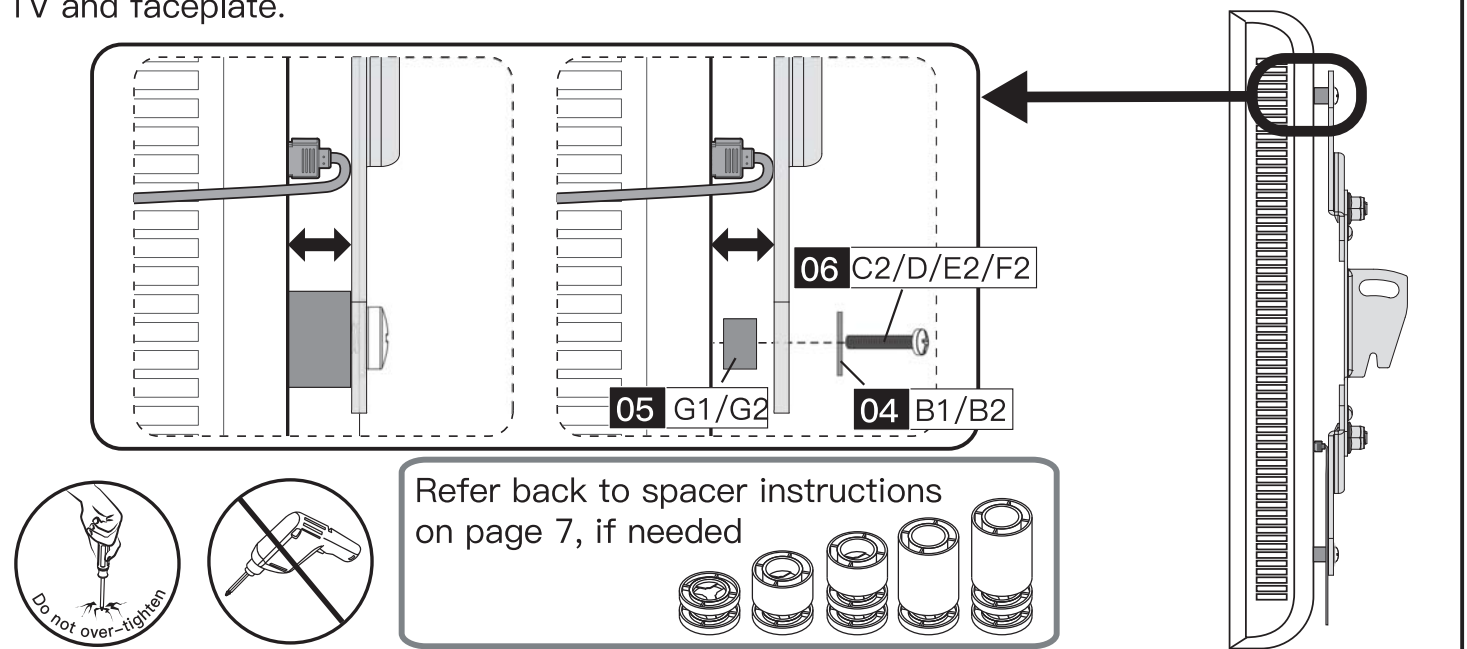



## Option E (For Recessed Holes)

The spacer needs to fill in the recessed holes on the back of the TV so that the faceplate are as close to the TV as possible.

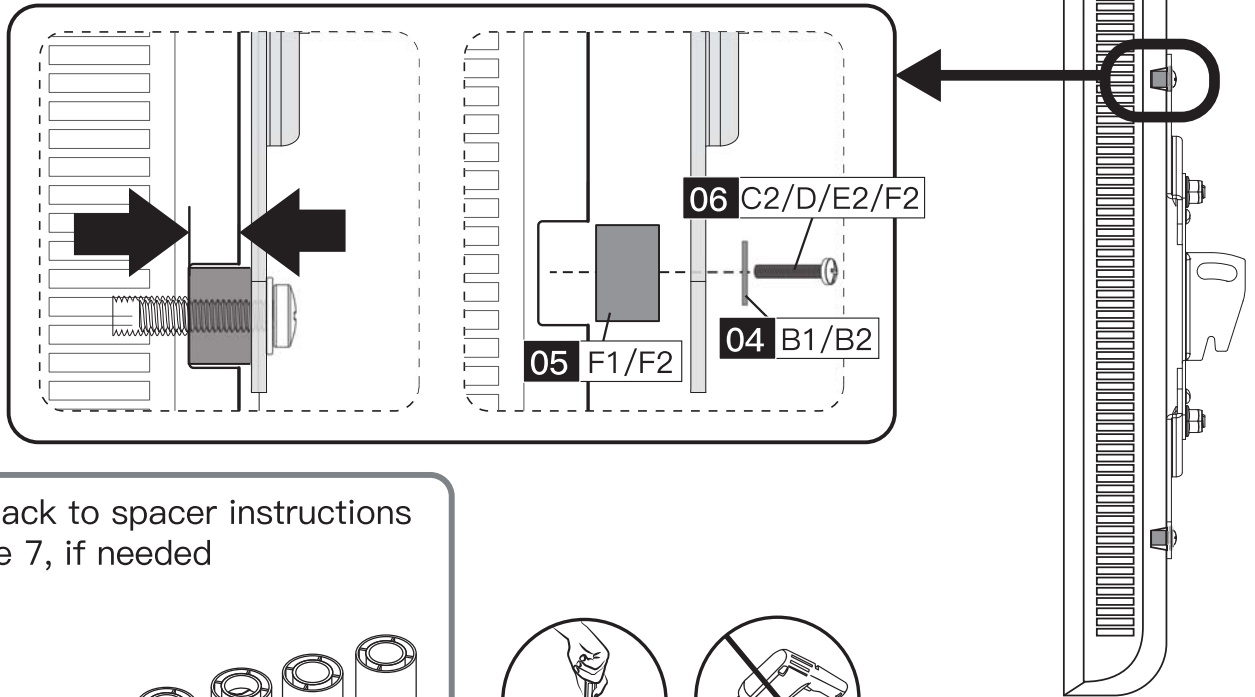

Refer back to spacer instructions on page 7, if needed

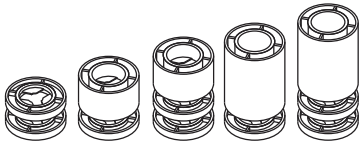

**!** When you finish securing the TV bolts into the TV, please remember to tighten the nuts [H2] using the socket wrench.

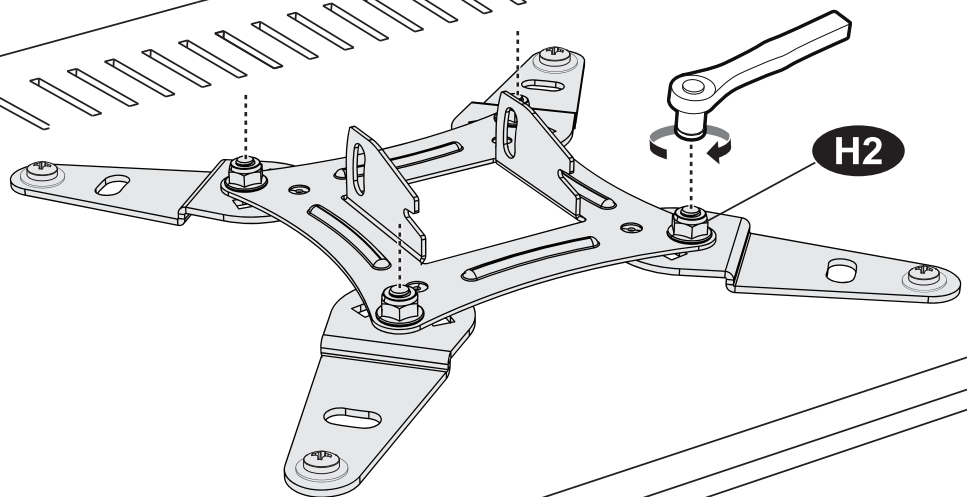

3/8 in (10mm)  
Socket Wrench  
(Not Included)

## Supplied Part and Hardware for Step 3

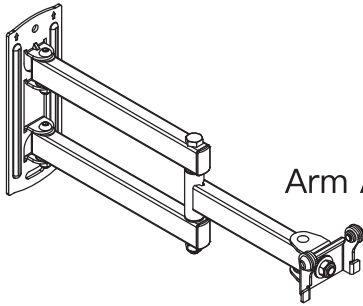

**03** x1

Arm Assembly/Wall Plate

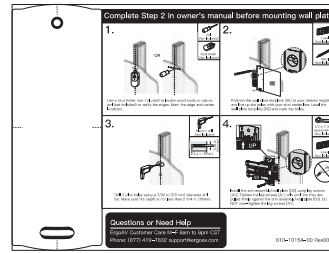

**08** x1

Wall Plate Template

**A1**

x2

Lag Screw  
5/16 x 2 3/4in

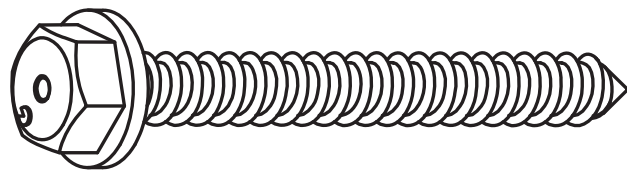

**A2**

x2

Wall  
Anchor  
10 x 60mm

**! CAUTION!**  
This anchor is for concrete  
walls **ONLY**. **DO NOT** use  
them in drywall or wood  
studs.



### Step 3 Attach the Arm Assembly/Wall Plate [03] to the Wall

For wood stud installation, follow STEP 3A

For concrete installation, follow STEP 3B

#### Step 3A Wood Stud Option

##### **! WARNING:**

Do not use a drill to tighten the lag screws. Only use a socket wrench.

Avoid potential personal injury or property damage! **DO NOT** over-tighten the lag screws [A1]. Tighten the lag screws [A1] only until they are pulled firmly against the wall plate.

**DO NOT USE ANCHOR FOR THIS STEP.**

Ensure the wall plate is securely fastened to the wall before continuing to the next step.



- Nominal wood stud size: common 2 x 4 in (51 x 102 mm)
- Stud center must be verified.

### 3A-1

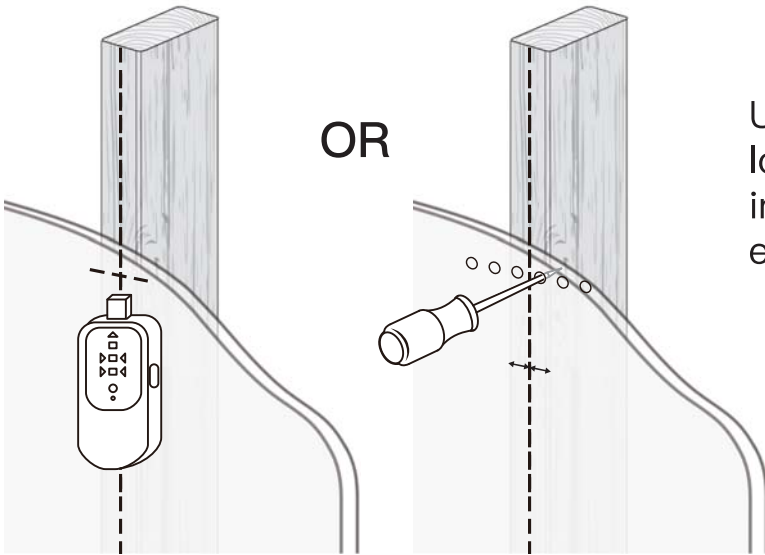

OR

Use a stud finder (not included) to locate wood studs or use an awl (not included) to verify the edges. Mark the edge and center locations.

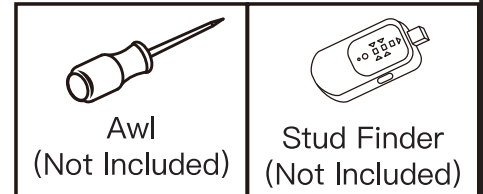

### 3A-2

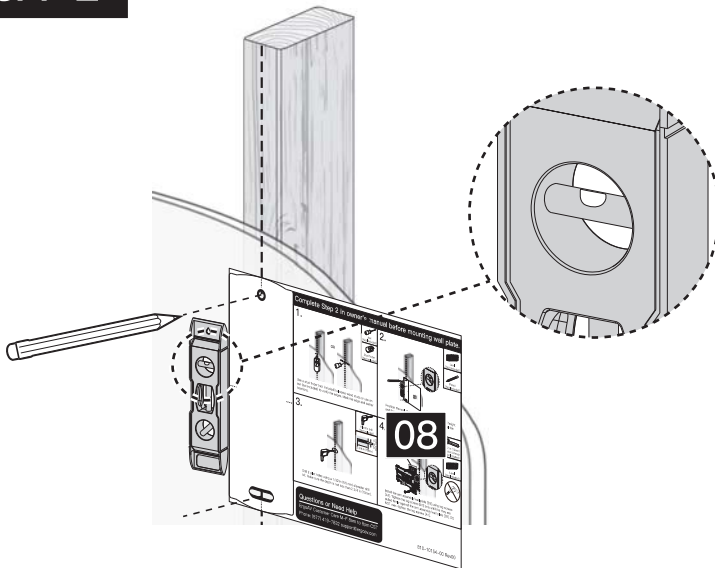

Position the wall plate template [08] at your desired height and line up the holes with your stud center line. Level the wall plate template [08] and mark the holes.

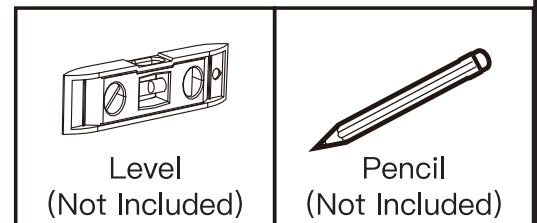

### 3A-3

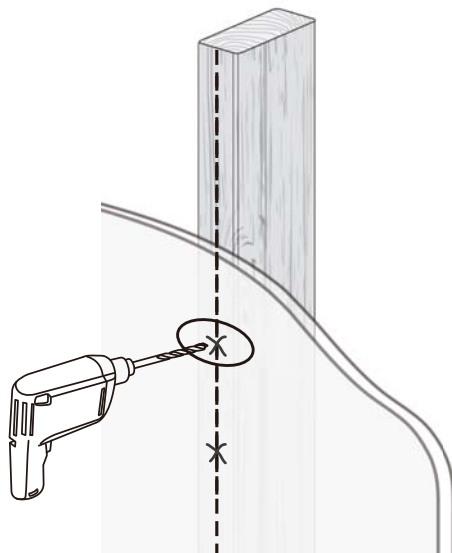

Drill 2 pilot holes using a 7/32 in (5.5 mm) diameter drill bit. Make sure the depth is not less than 2 3/4 in (70mm).

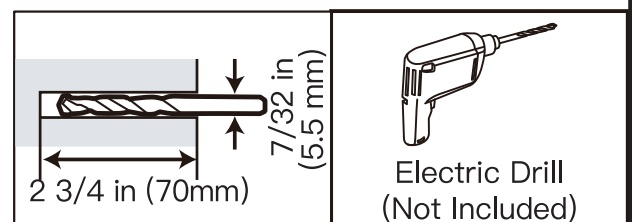

### 3A-4

**NOTE:** Do not use a drill to tighten the lag screws. Only use a socket wrench.

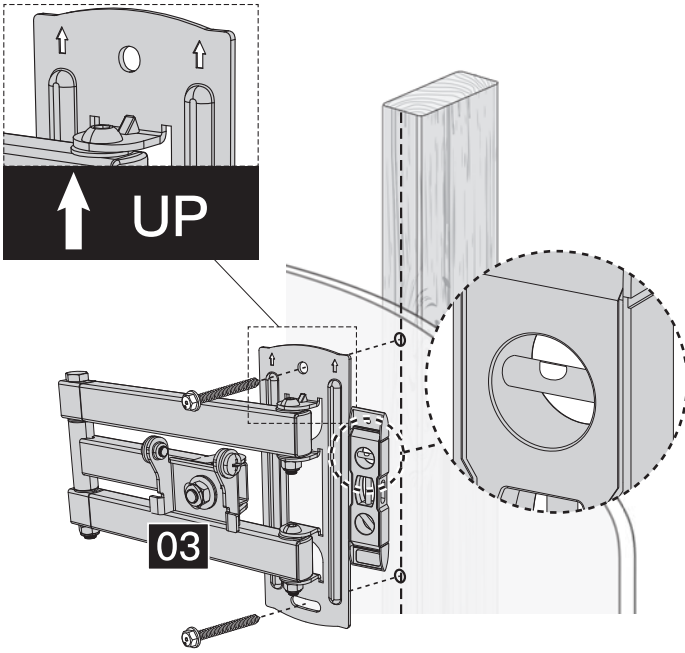

Install the arm assembly/wall plate [03] using lag screws [A1]. Tighten the lag screws [A1] only until they are pulled firmly against the arm assembly/wall plate [03]. **DO NOT** over-tighten the lag screws [A1].

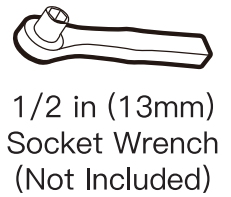
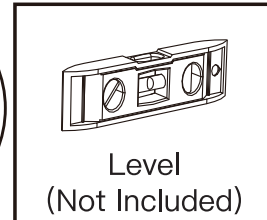
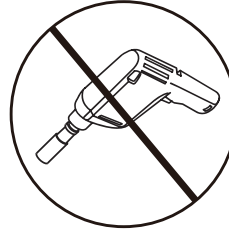

## Step 3B Solid Concrete Wall Option

### ⚠ WARNING:

- Avoid potential personal injury or property damage! **DO NOT** over-tighten the lag screws [A1]. Tighten the lag screws [A1] only until they are pulled firmly against the wall plate.
- Ensure the wall plate is securely fastened to the wall before continuing to the next step.
- Mount the wall plate directly onto the concrete surface without any covering.
- The thickness of the concrete wall must exceed 5.5 in (140 mm). Do not use a drill for tightening the lag screws! Only use a socket wrench.

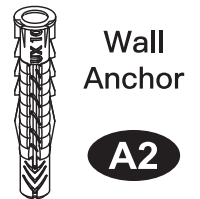

### 3B-1

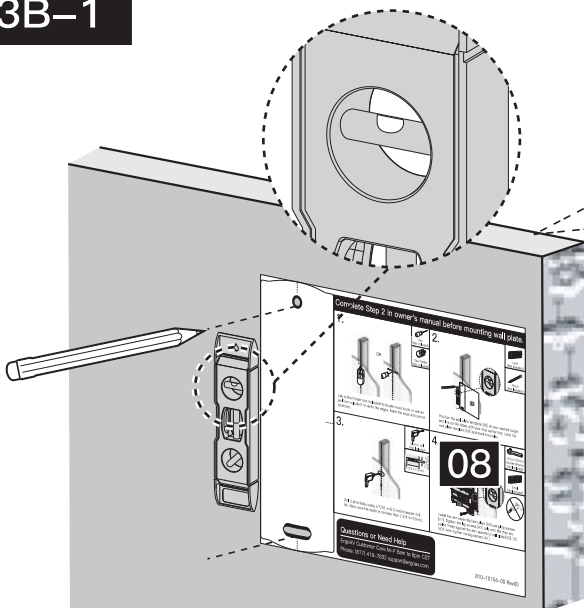

Position wall plate template [08] at your desired height, level the wall plate template [08] and mark the pilot hole locations.

### 3B-2

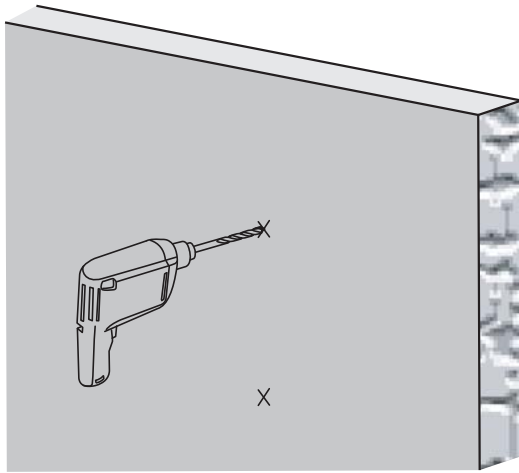

Drill 2 pilot holes using a 3/8 in (10mm) diameter drill bit. Make sure the depth is not less than 3 in (75mm).

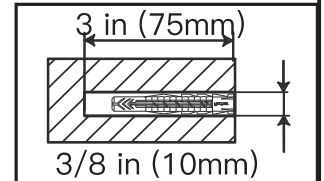

### 3B-3

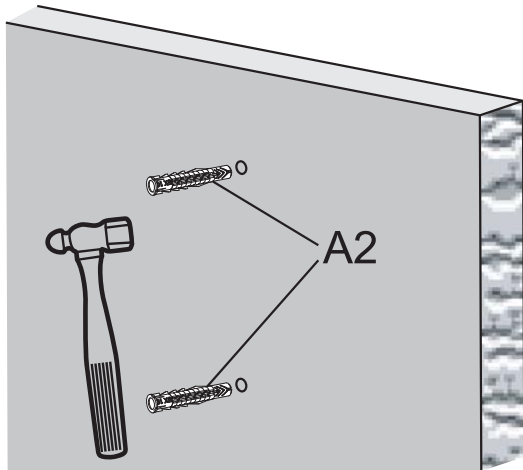

Use the hammer to knock anchors [A2] into the wall. Be sure the anchors [A2] are seated flush with the concrete surface.

### 3B-4

**NOTE:** Do not use a drill to tighten the lag screws. Only use a socket wrench.

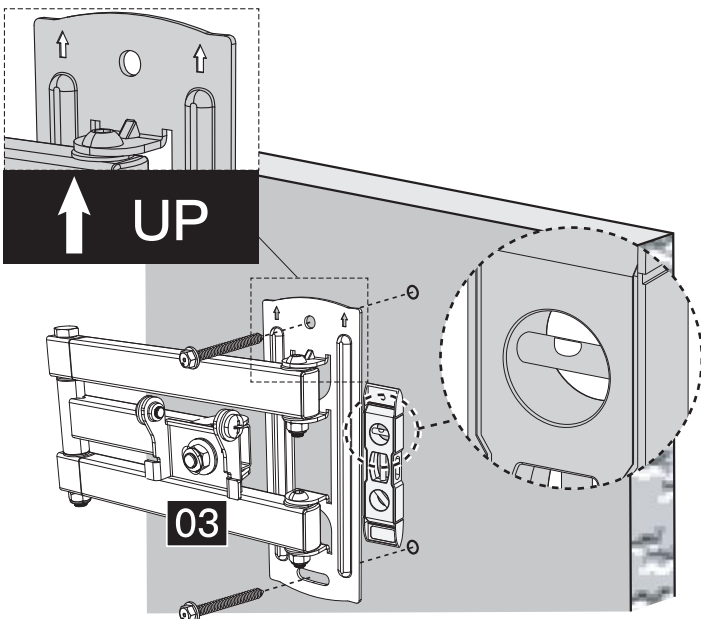

Install wall plate using lag screws [A1]. Tighten the lag screws [A1] only until they are pulled firmly against the wall plate. DO NOT over-tighten the lag screws [A1].

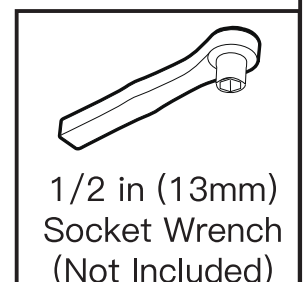
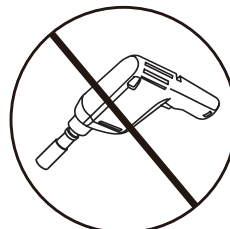

## Supplied Hardware for Step 4 and 5



### Step 4 Secure the TV onto the Arm

4-1 Remove the preassembled bolts [T] and washers [W] from the arm, and keep them for the use in step 4-3.

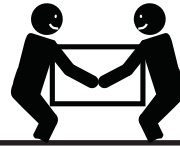
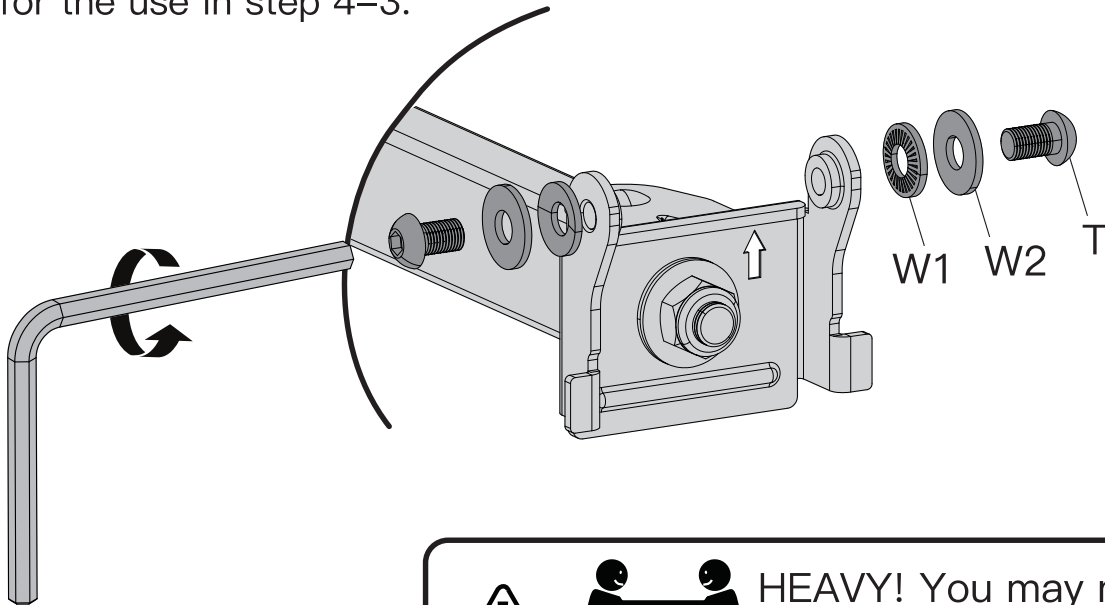

**HEAVY!** You may need assistance with this step.

4-2 Hang the TV to the arm.

4-3 While holding TV on arm, tighten the bolts [T] and washers [W] to secure TV to the arm.

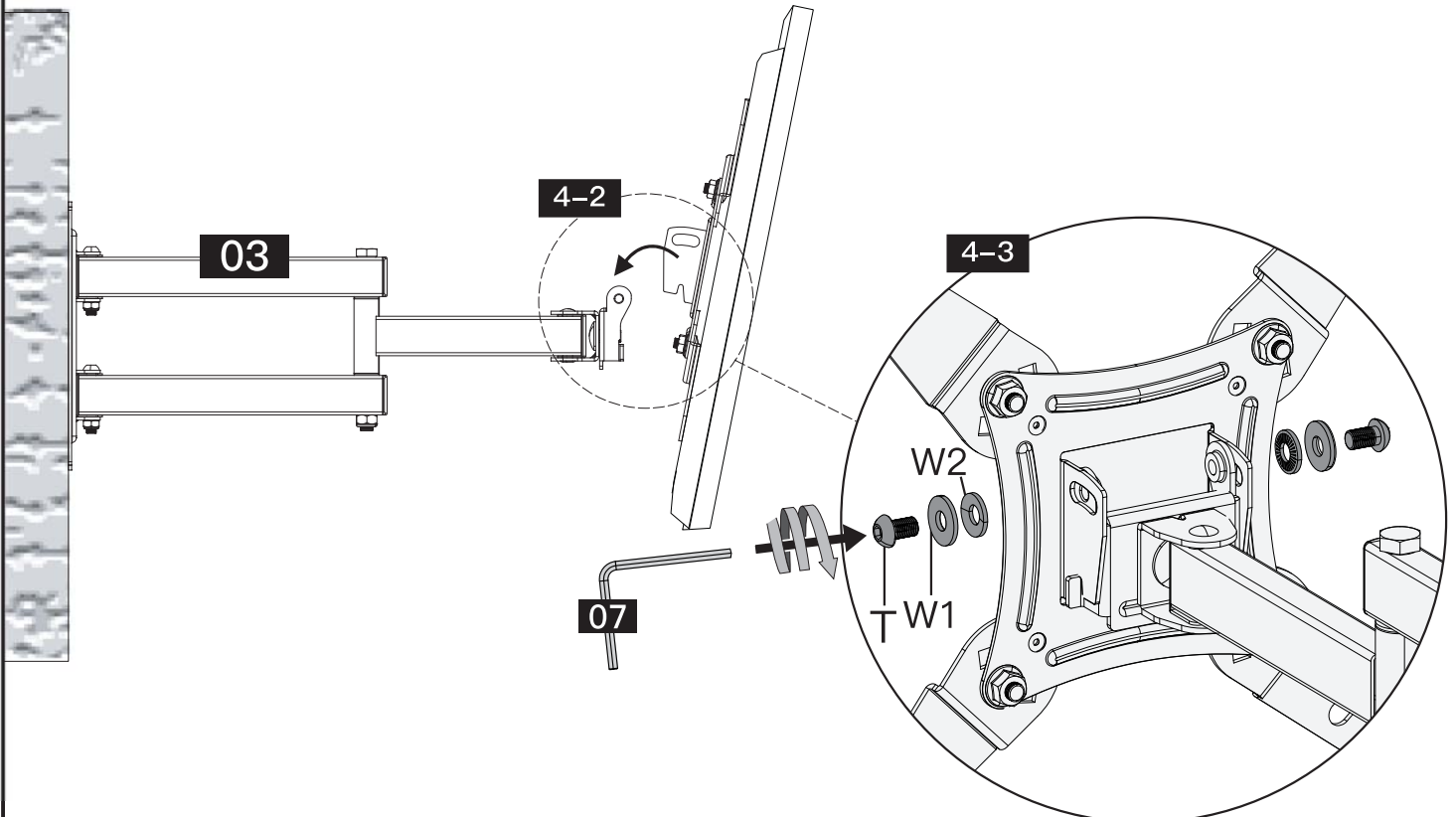

## Step 5 Tilt Adjustment

1. Loosen both tilt nut [T] slightly.
2. Adjust TV to your desired tilt angle.
3. Re-tighten both tilt nut [T] to fix the tilt angle.



5/32 in (4mm)  
Allen Key  
**07** x1

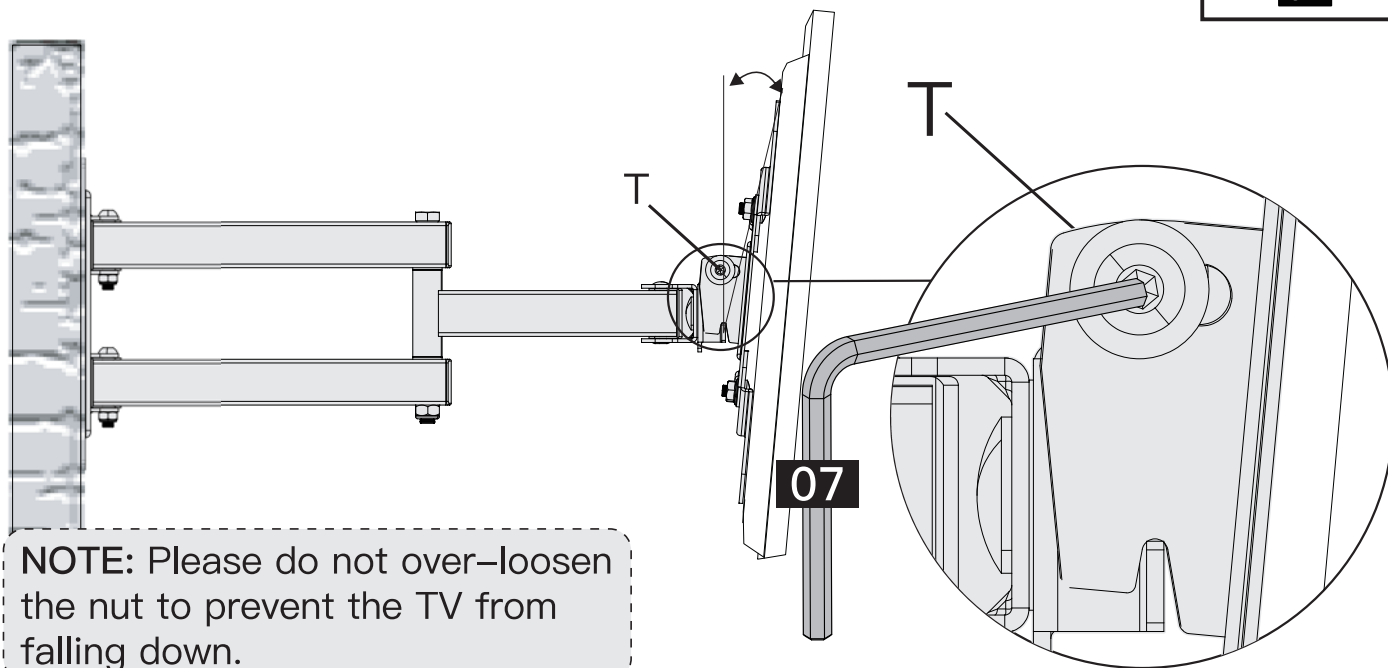

## Step 6 Level Adjustment

1. Slightly loosen the preassembled nut [L] using a wrench.
2. Level your TV.
3. Retighten the preassembled nut [L] using wrench to secure the TV in place.

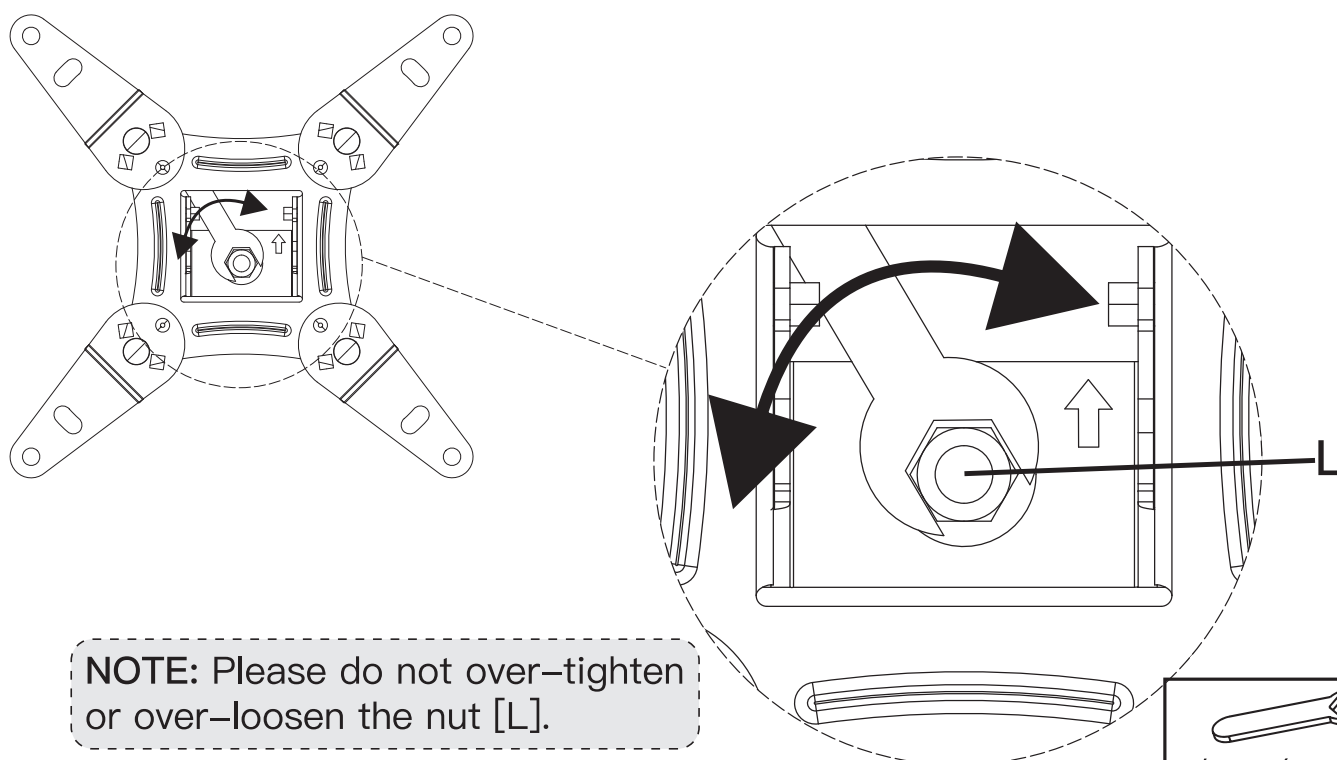

1/2 in (13 mm)  
Wrench  
(Not Included)

## CONSIGNES DE SECURITE IMPORTANTES

**⚠ DANGER !** Veuillez lire attentivement toutes les instructions avant de tenter l'installation. Si les instructions ne vous semblent pas claires ou si vous avez des questions, veuillez contacter notre service d'assistance technique au (877) 419-7832 ou notre service clientèle à l'adresse [support@ergoav.com](mailto:support@ergoav.com).

**⚠ ATTENTION :** L'utilisation avec des produits plus lourds que les poids maximums indiqués peut entraîner une instabilité et des blessures possibles.

- N'utilisez pas ce produit à des fins qui ne sont pas explicitement spécifiées dans ce manuel. Ne dépassez pas la capacité de charge. Nous ne sommes pas responsables des dommages ou blessures causés par un montage incorrect, un assemblage incorrect ou une utilisation inappropriée.
- Ce produit est conçu pour être utilisé dans les murs à ossature de bois et les murs en béton massif. – NE PAS installer dans une cloison sèche seule
- Le mur doit être capable de supporter quatre fois le poids du TV et du support combinés.
- Utilisez ce système de montage uniquement pour l'usage auquel il est destiné, tel que décrit dans ces instructions. N'utilisez pas d'accessoires non recommandés par le fabricant.
- Ne pas utiliser à l'extérieur.
- Acheminez correctement les cordons et les câbles pour éviter tout dommage mécanique.
- SAUVEGARDER CES INSTRUCTIONS

## Restrictions de poids



Si votre TV pèse plus lourd, n'utilisez pas ce produit.

### ⚠ AVERTISSEMENT

NE PAS dépasser le poids maximum indiqué. Ce système de montage est destiné à être utilisé uniquement dans les limites des poids maximaux indiqués. L'utilisation de produits plus lourds que les poids maximums indiqués peut entraîner une défaillance du support et de ses accessoires, causant des dommages et/ou des blessures.

## Vérifiez le modèle VESA de votre TV avant l'installation

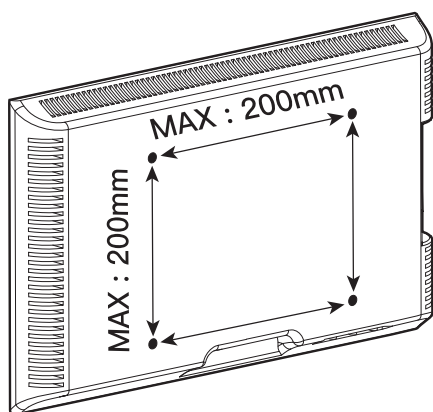

75 mm ≈ 3 po  
100 mm ≈ 4 po  
200 mm ≈ 7 7/8 po

Minimum : 75mm x 75mm / 3 pouce x 3 pouce (W x H)

Maximum : 200mm x 200mm / 7 7/8 pouce x 7 7/8 pouce (W x H)

Si le motif VESA de votre Téléviseur est inférieur à 75mm x 75mm ou supérieur à 200mm x 200mm, ce support n'est PAS COMPATIBLE avec votre Téléviseur. Veuillez contacter notre support technique au (877) 419-7832 ou [support@ergoav.com](mailto:support@ergoav.com) pour trouver un support compatible.



## Outils nécessaires (non inclus)



Détecteur de goujons



Ailette



Mètre ruban



Crayon

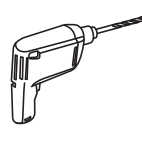

Perceuse électrique

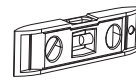

Niveau



Tournevis cruciform



Perceuse à bois de 7/32 po (5,5 mm)



Clé à douille de 3/8 po (10 mm)



Clé à douille de 1/2 po (13 mm)

(Nécessaire pour les installations en béton)



Foret à béton de 3/8 po (10mm)



Marteau-piqueur

## Vérifiez la construction de vos murs

**! ATTENTION**

NE PAS installer dans une cloison sèche seule

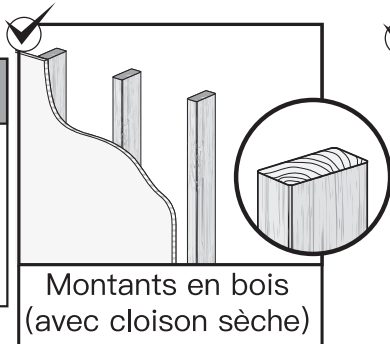

Montants en bois (avec cloison sèche)

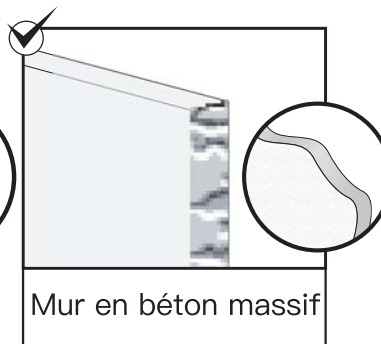

Mur en béton massif

Si vous n'êtes pas sûr de la construction du mur, veuillez contacter notre ligne d'assistance technique au (877) 419-7832 ou notre service clientèle à l'adresse [support@ergoav.com](mailto:support@ergoav.com).

## Pièces et matériel fournis

**! AVERTISSEMENT :** Ce produit contient des petits objets susceptibles de présenter un risque d'étouffement en cas d'ingestion.

Avant de commencer l'assemblage, vérifiez que toutes les pièces sont incluses et en bon état. N'utilisez pas de pièces endommagées ou défectueuses. Si vous avez besoin de pièces de rechange, veuillez contacter notre ligne d'assistance technique au (877) 419-7832 ou le service clientèle à l'adresse [support@ergoav.com](mailto:support@ergoav.com) pour trouver un support compatible.

**VEUILLEZ NOTER :** le matériel inclus dans cet ensemble ne sera pas utilisé en totalité.

## Pièces et matériel fournis pour l'étape 1

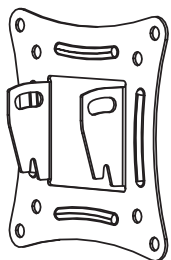

**01** x1

Plaque frontale

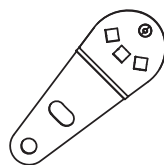

**02** x4

Support d'extension

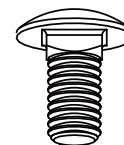

Boulon  
M6 x 12mm  
**[H1] X4**



Écrou  
M6  
**[H2] X4**

## Étape 1 Choisissez la combinaison qui convient à votre modèle de trou VESA

Option A : Il n'est pas nécessaire de fixer les supports d'extension à la plaque frontale. Passez à la page 06

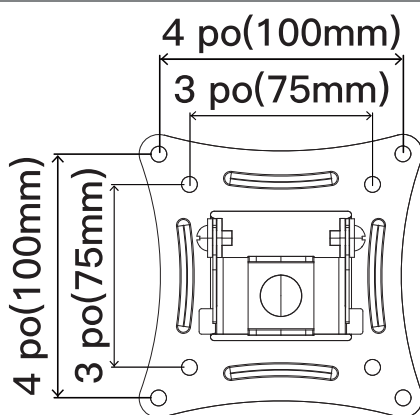

Pour le modèle de trou VESA :  
3 x 3 po/75 x 75mm  
4 x 4 po/100 x 100mm

Option B : Il faut fixer les supports d'extension à la plaque frontale. Voir Fig. 1 à Fig. 3

### REMARQUE :

La petite bosse du support d'extension [02] doit être alignée avec le trou de la plaque frontale [01].

Ne serrez pas fermement les boulons [H1] et les écrous [H2] avant d'avoir terminé l'étape 2.

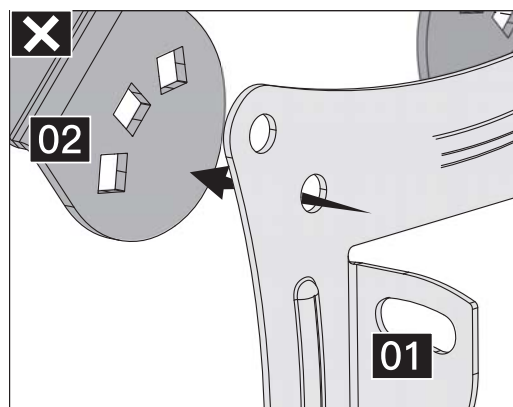
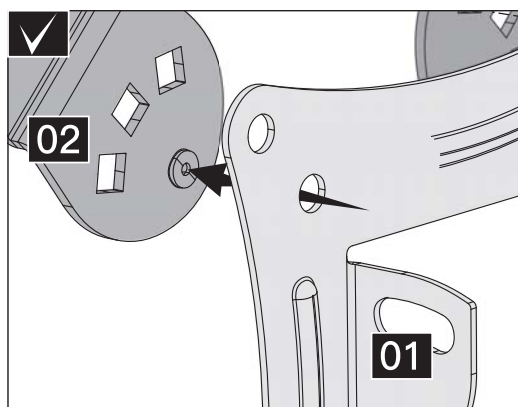

Fig. 1 Pour le modèle de trou VESA : 8 x 8 po/200 x 200mm

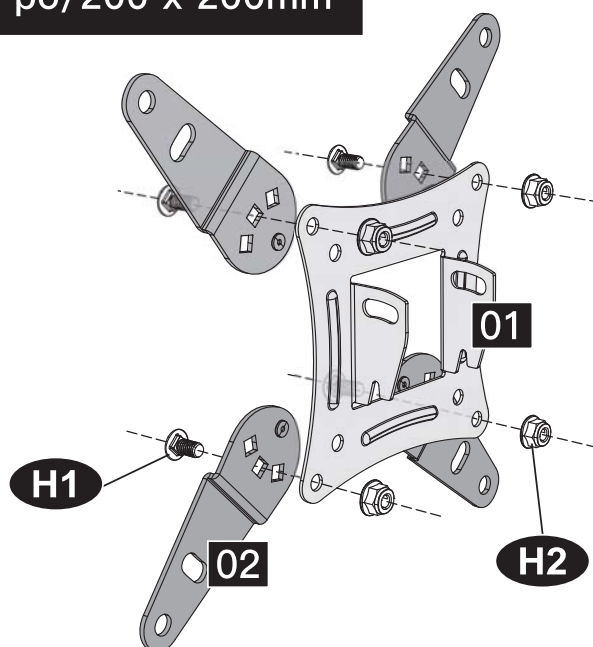
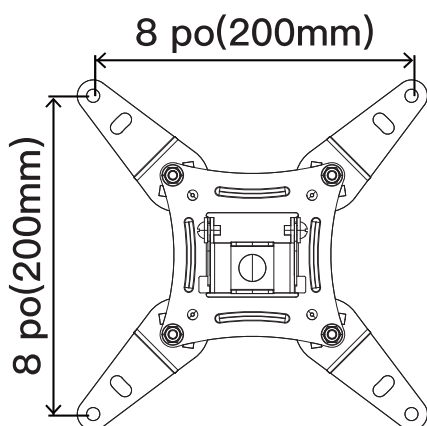

Fig. 2 Pour le modèle de trou VESA : 4 x 8 po/100 x 200mm

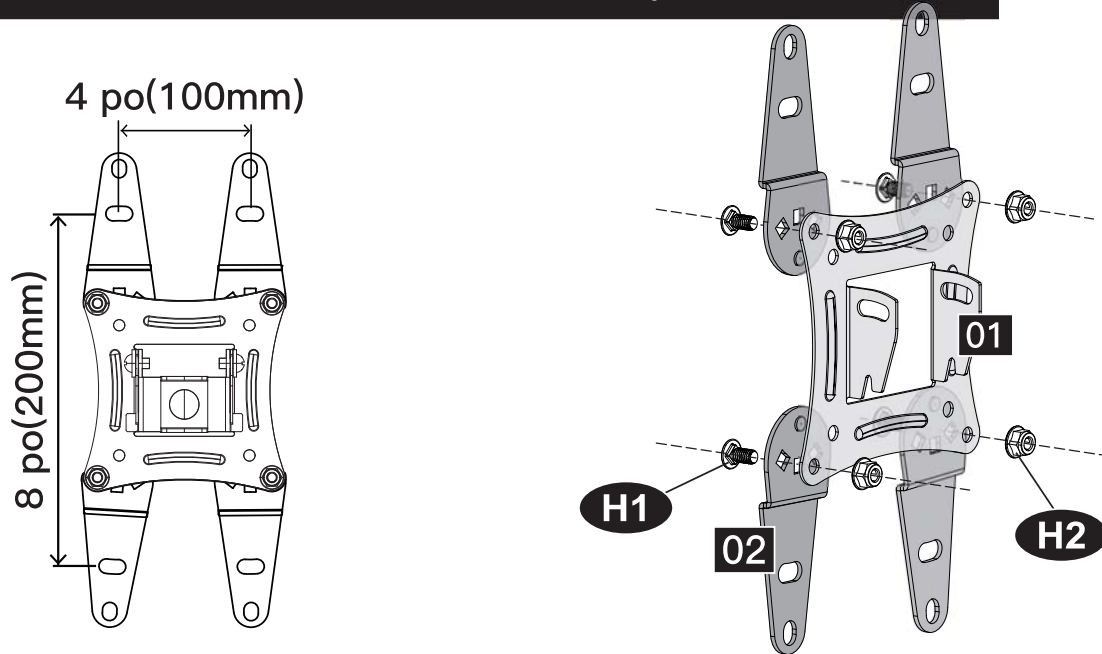
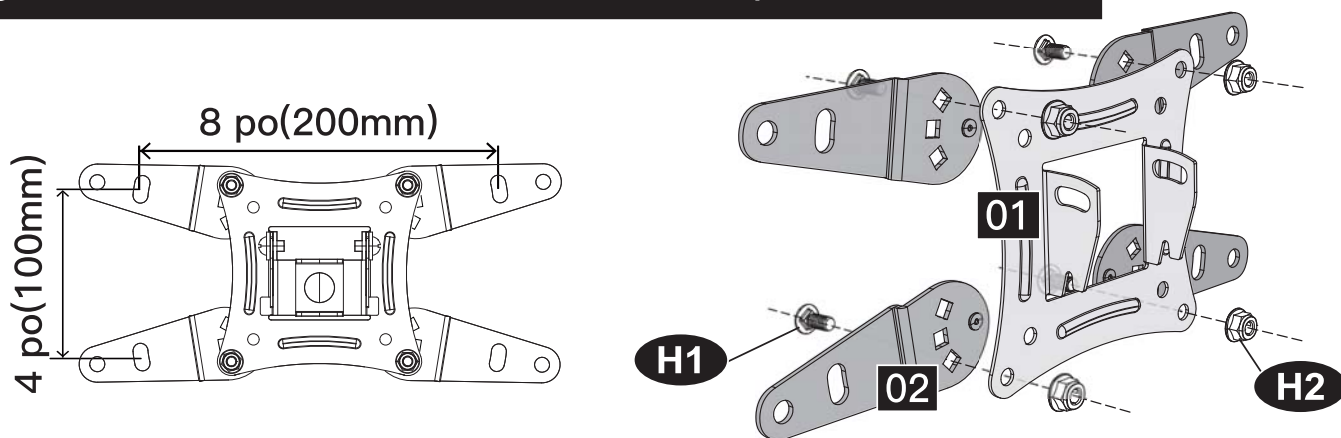

Fig. 3 Pour le modèle de trou VESA : 8 x 4 po/200 x 100mm



## Pièces et matériel fournis pour l'étape 2

### 04 Rondelles

### 05 Entretoises [Si nécessaire]

REMARQUE : Les rondelles et les entretoises sont indiquées en taille réelle.

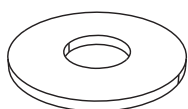

[B1] x4  
M4/M5

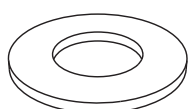

[B2] x4  
M6/M8



[G1] x4  
8.5x18x2.5mm



[G2] x8  
8.5x18x10mm

### 06 Boulons de TV [Une seule taille de boulon convient à votre TV]

REMARQUE : la vis est représentée à sa taille réelle.

M4

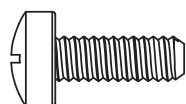

M4 x 12mm  
[C1] x4



M4 x 30mm  
[C2] x4

**M5**

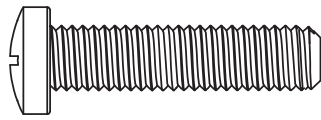

M5 x 25mm  
[D] x4

**M6**

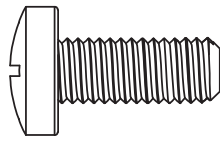

M6 x 15mm  
[E1] x4

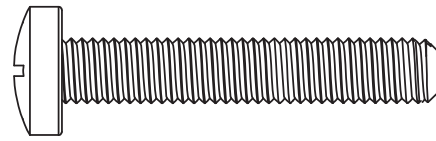

M6 x 35mm  
[E2] x4

**M8**

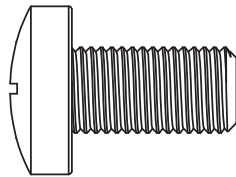

M8 x 15mm  
[F1] x4

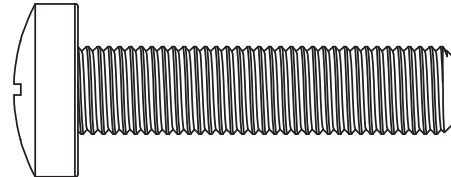

M8 x 35mm  
[F2] x4

## Étape 2 Fixez les Supports TV sur le TV

### Sélectionnez les Boulons de TV

Une seule taille de boulon convient à votre TV.

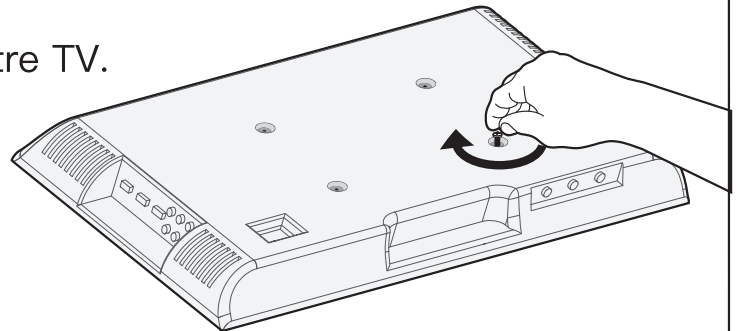
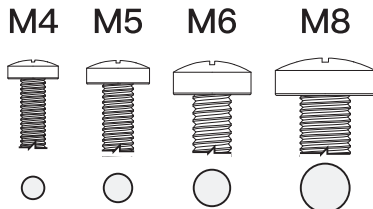

**REMARQUE :** Ne serrez pas trop les boulons de TV pour ne pas l'endommager. Longueur de la vis : vérifiez que le filetage est correctement engagé avec les boulons ou la combinaison vis/entretoises. Nous recommandons un engagement du filetage sur au moins 5 tours.

- Trop court, le TV ne sera pas maintenu.
- Trop long, le TV sera endommagé.

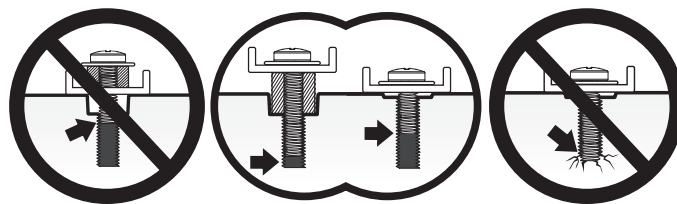

Trop court

Correct

Trop long

**VEUILLEZ NOTER :** lors de l'utilisation des entretoises, il est important de noter qu'elles peuvent être utilisées sur plusieurs couches (c'est-à-dire empilées). Si vous rencontrez des difficultés pour comprendre comment installer les boulons ou les entretoises du TV, veuillez contacter notre service d'assistance technique au (877) 419-7832 ou notre service clientèle à l'adresse [support@ergoav.com](mailto:support@ergoav.com).

# Les pièces nécessaires si vous avez un TV tel qu'indiqué ci-après

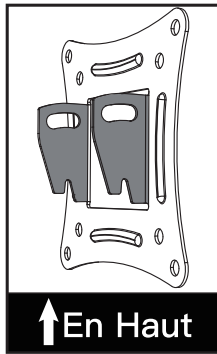
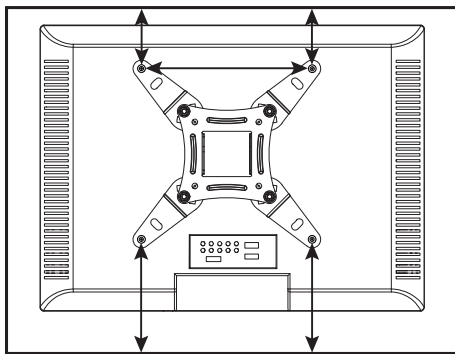
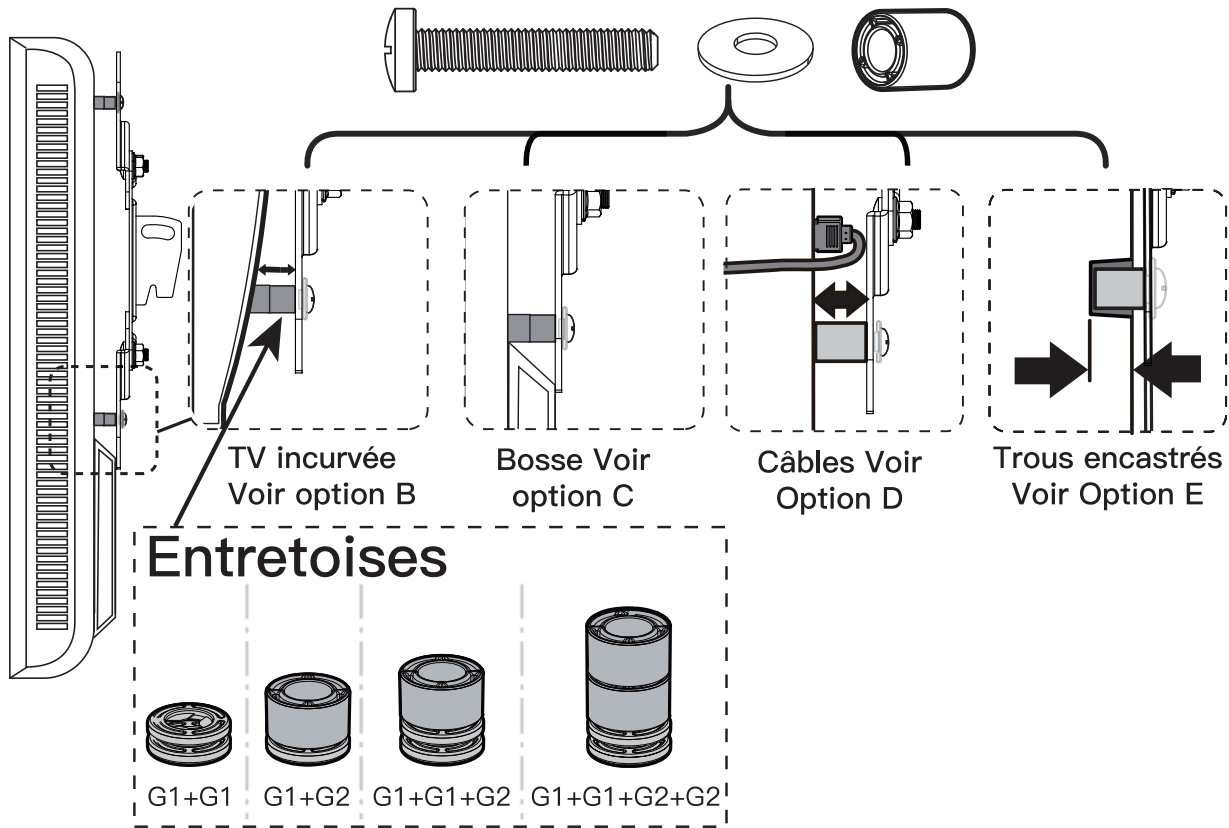

⚠ Lorsque vous fixez la façade à l'arrière du TV, assurez-vous que les crochets orientés vers le bas sont dirigés vers le bas du TV et que la façade est également centrée sur l'arrière du TV.

⚠ **VEUILLEZ NOTER** : les emplacements des trous des boulon sur votre TV peuvent varier en fonction du modèle du fabricant du TV. Nous représentons seulement les emplacements possibles des trous des vis.

## Option A (pour les TV à dos plat)

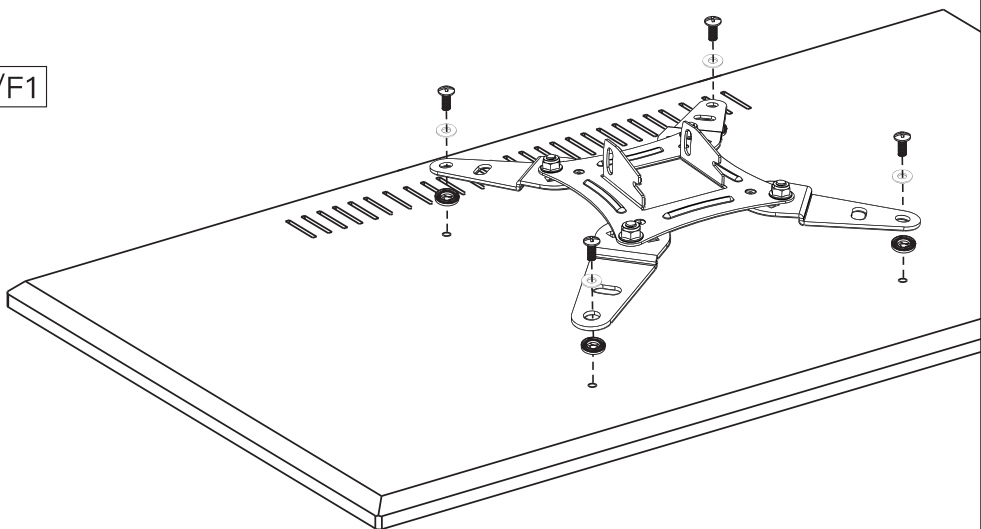
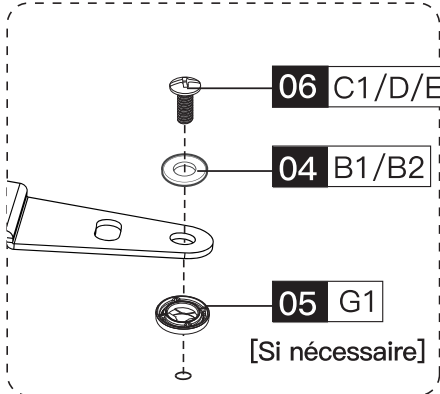

### Option B (pour les TV à dos incurvé)

La hauteur des entretoises doit être suffisante pour éviter que la courbe à l'arrière du TV n'interfère avec la plaque de montage.

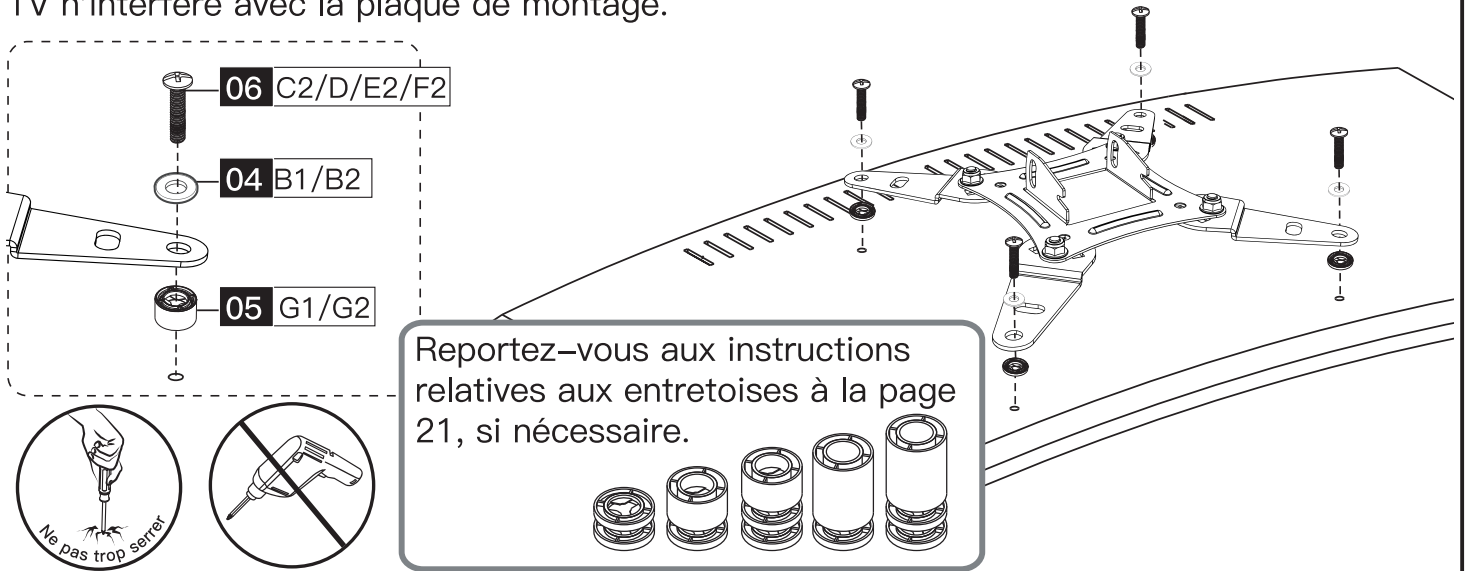

### Option C (pour les TV avec une "bosse")

Les entretoises doivent être suffisamment hautes pour qu'il n'y ait pas d'espace entre la plaque frontale et la bosse à l'arrière du Téléviseur.

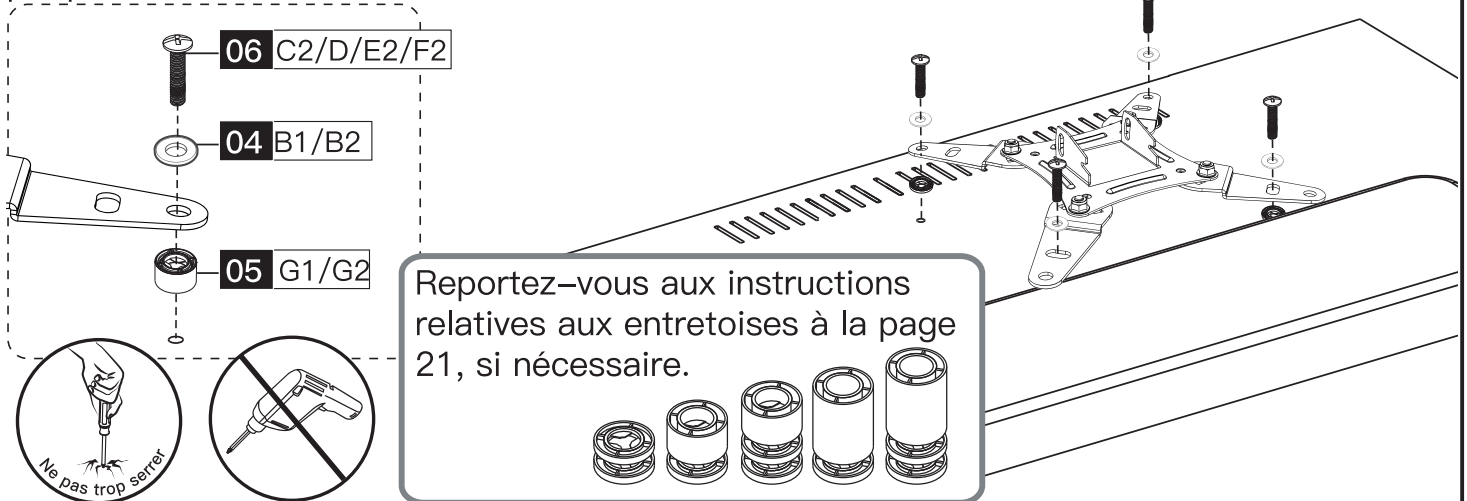

### Option D (pour l'interférence des câbles)

Pour éviter les interférences entre les câbles, utilisez des entretoises 05 pour créer un espace supplémentaire entre le Téléviseur et la plaque frontale.

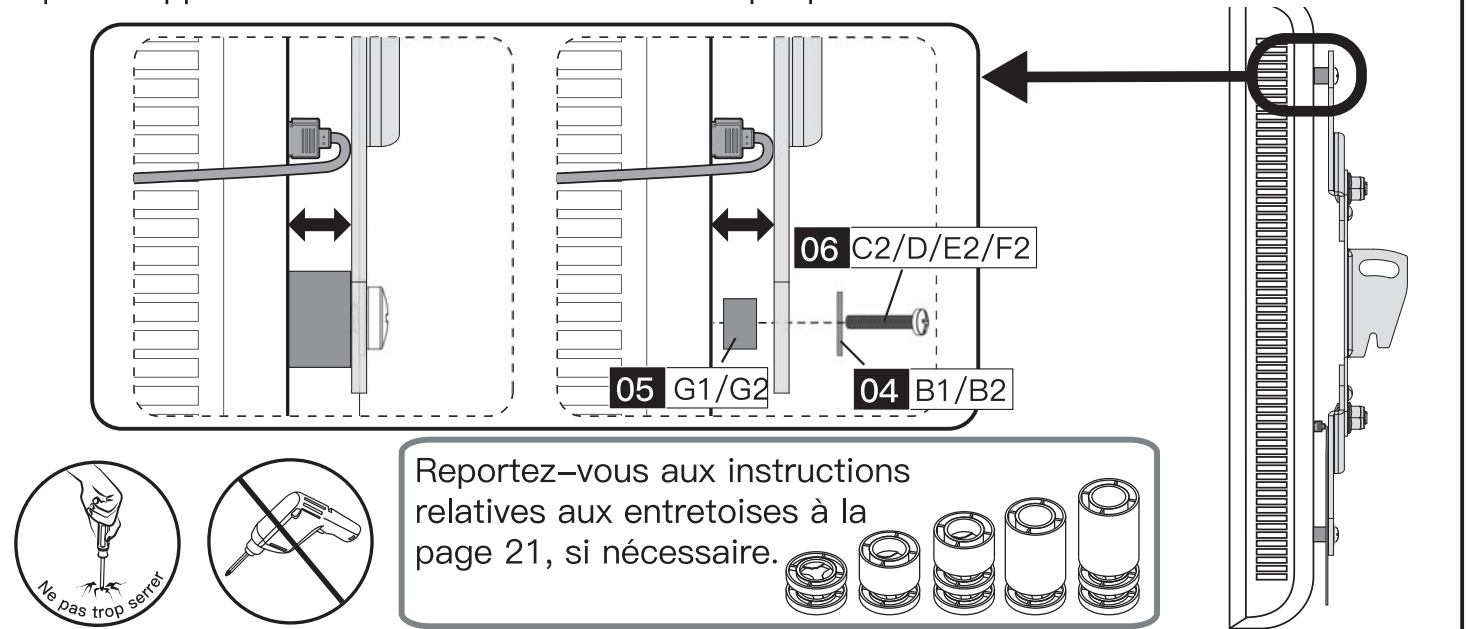

## Option E (pour les trous encastrés)

L'entretoise doit remplir les trous en retrait à l'arrière du TV afin que les plaque frontale soient aussi proches que possible du TV.

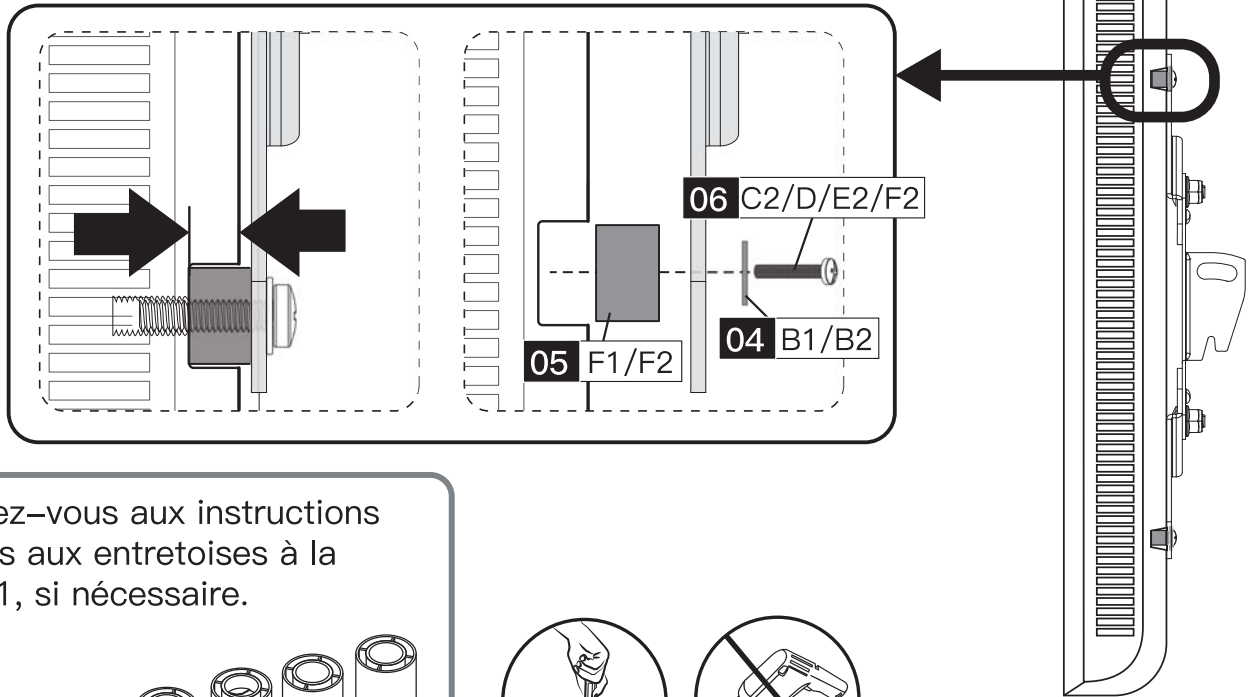

Reportez-vous aux instructions relatives aux entretoises à la page 21, si nécessaire.

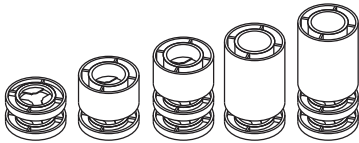

**!** Lorsque vous avez fini de fixer les boulons TV dans le téléviseur, n'oubliez pas de serrer les écrous [H2] à l'aide d'une clé à douille.

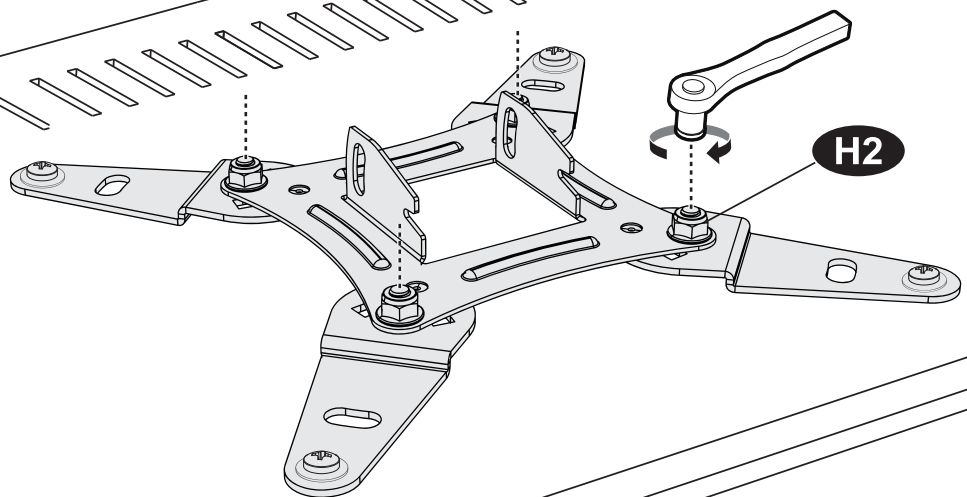

3/8 po (10mm)  
Clé à douille  
(non inclus)

## Pièces et matériel fournis pour l'étape 3

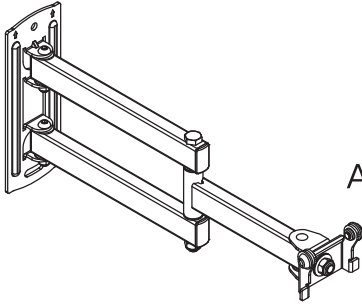

**03** x1

Assemblage de bras /  
Plaque murale

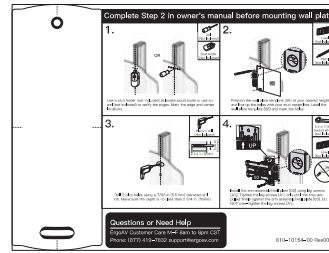

**08** x1

Modèle de plaque

**A1**

x2

Tire-fond  
5/16 x 2 3/4 po

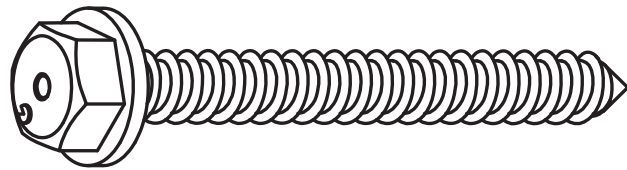

**A2**

x2 Ancre de mur  
10 x 60mm

**! ATTENTION!**  
Cet ancrage est destiné  
aux murs en béton  
**UNIQUEMENT. NE PAS** les  
utiliser dans des cloisons  
sèches ou les montants en  
bois.

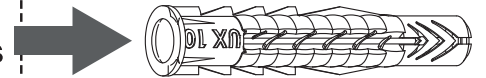

## Étape 3 Fixation de l'Assemblage de bras / Plaque murale [03] au mur

Pour l'installation de montants en bois, suivre l'ÉTAPE 3A

Pour l'installation de béton, suivre l'ÉTAPE 3B

### Étape 3A Option montants en bois

#### **! AVERTISSEMENT :**

N'utilisez pas de perceuse pour serrer les tire-fonds ! Utilisez uniquement une clé à douille.

Évitez les blessures corporelles ou les dommages matériels potentiels ! **NE SERREZ PAS** trop les tire-fonds [A1]. Ne serrez les tire-fonds [A1] que jusqu'à ce qu'ils soient fermement tirés contre la plaque murale.

**NE PAS UTILISER D'ANCRAGE POUR CETTE ÉTAPE.**

Assurez-vous que la plaque murale est bien fixée au mur avant de passer à l'étape suivante.



- Taille nominale des montants en bois : commun 2 x 4 po (51 x 102 mm)
- Le centre des montants doit être vérifié.



### 3A-1

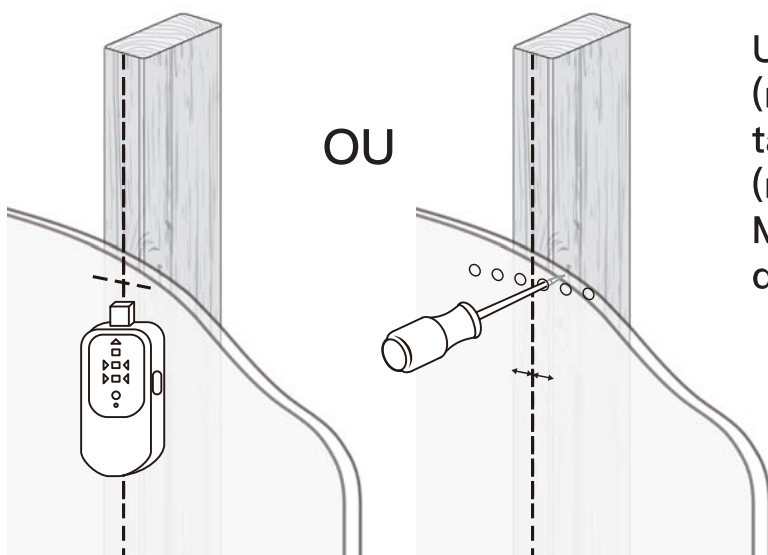

Utilisez un détecteur de montants (non inclus) pour localiser les montants en bois ou utilisez une alène (non incluse) pour vérifier les bords. Marquez les emplacements du bord et du centre.

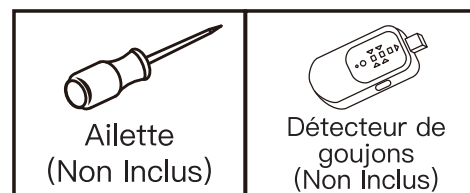

### 3A-2

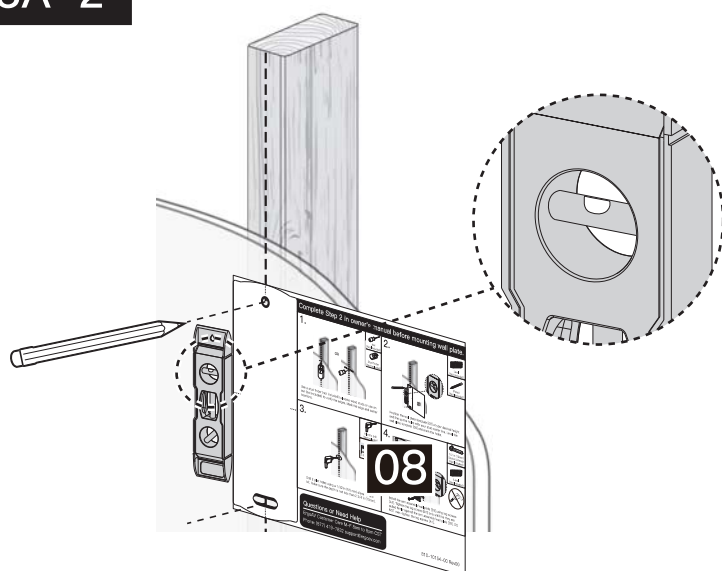

Positionnez le modèle de plaque murale [08] à la hauteur souhaitée et alignez les trous avec la ligne centrale de votre montant. Mettez à niveau le modèle de plaque murale [08] et marquez les trous.

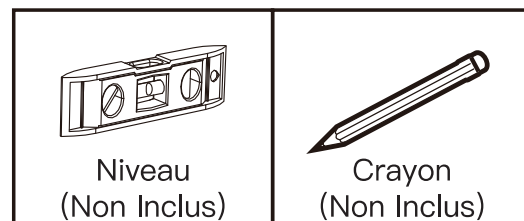

### 3A-3

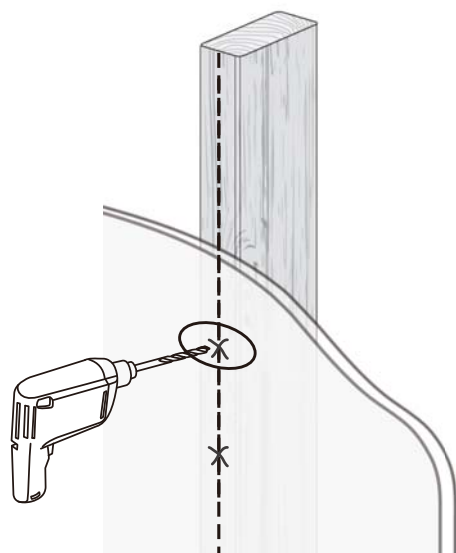

Percez 2 trous pilotes à l'aide d'un foret de 7/32 po (5,5 mm) de diamètre. Assurez-vous que la profondeur n'est pas inférieure à 2 3/4 po (70 mm).

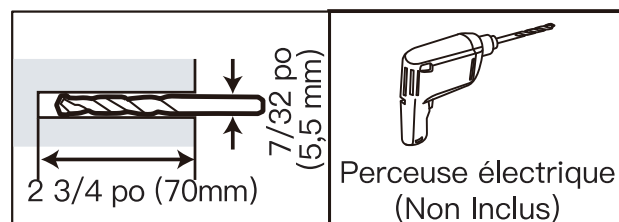

### 3A-4

REMARQUE : N'utilisez pas de perceuse pour serrer les tire-fonds. Utilisez uniquement une clé à douille.

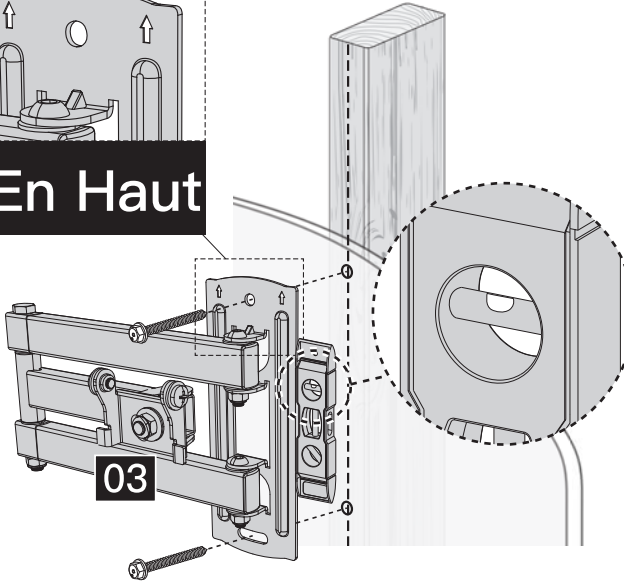
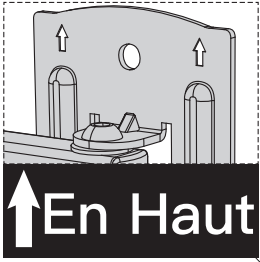

Installez l'Assemblage de bras / Plaque murale [03] à l'aide des tire-fonds [A1]. Serrez les tire-fonds [A1] jusqu'à ce qu'ils soient fermement tirés contre l'Assemblage de bras / Plaque murale [03]. NE SERREZ PAS trop les tire-fonds [A1].

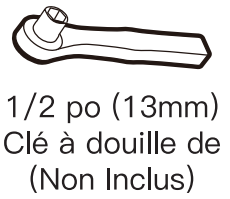
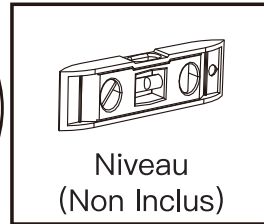
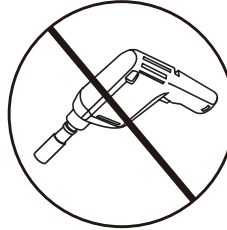

## Étape 3B Option de mur en béton massif

### ⚠ Avertissement :

- Évitez les blessures corporelles ou les dommages matériels potentiels ! NE SERREZ PAS trop les tire-fonds [A1]. Ne serrez les tire-fonds [A1] que jusqu'à ce qu'ils soient fermement tirés contre la plaque murale.
- Assurez-vous que la plaque murale est bien fixée au mur avant de passer à l'étape suivante.
- Montez la plaque murale directement sur la surface en béton sans aucun revêtement.
- L'épaisseur du mur en béton doit dépasser 5,5 po (140 mm). N'utilisez pas de perceuse pour serrer les tire-fonds ! Utilisez uniquement une clé à douille.



Ancre de mur  
**A2**

### 3B-1

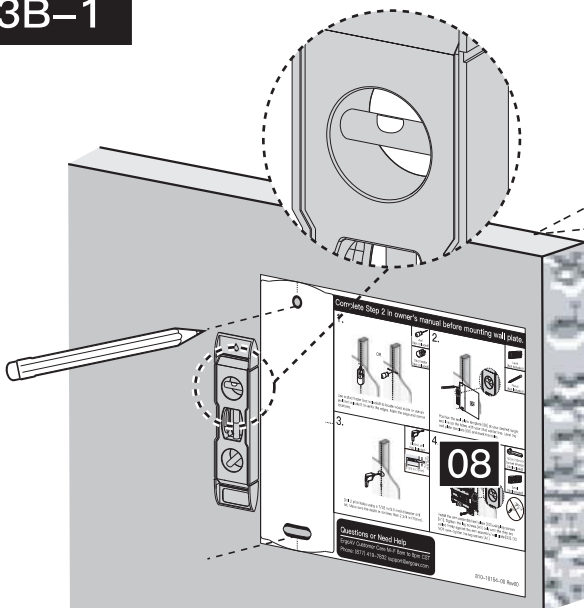

Placez le modèle de plaque murale [08] à la hauteur souhaitée, mettez le modèle de plaque murale [08] à niveau et marquez l'emplacement des avant-trous.

### 3B-2

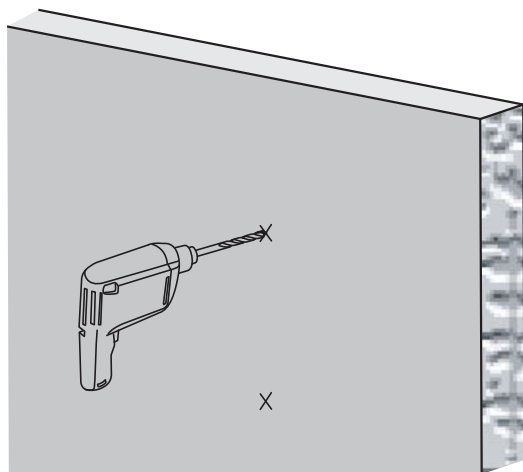

Percez 2 trous pilotes à l'aide d'un foret de 3/8 po (10mm) de diamètre. Assurez-vous que la profondeur n'est pas inférieure à 3 po (75 mm).

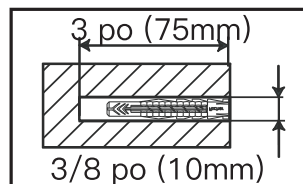

### 3B-3

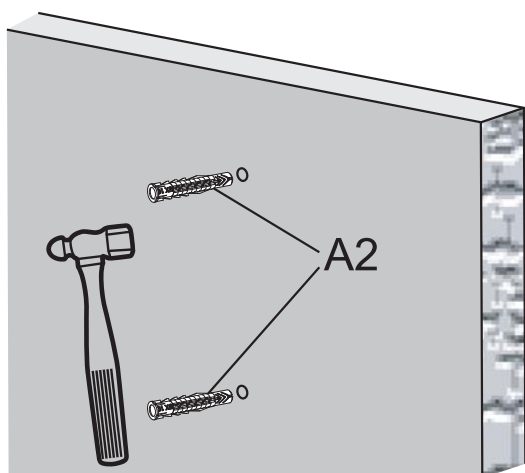

Utilisez le marteau pour enfoncer les ancrages [A2] dans le mur. Veillez à ce que les ancrages [A2] soient posés au ras de la surface du béton.

### 3B-4

**REMARQUE :** N'utilisez pas de perceuse pour serrer les tire-fonds. Utilisez uniquement une clé à douille.

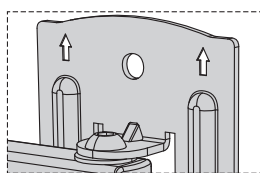

↑ En Haut

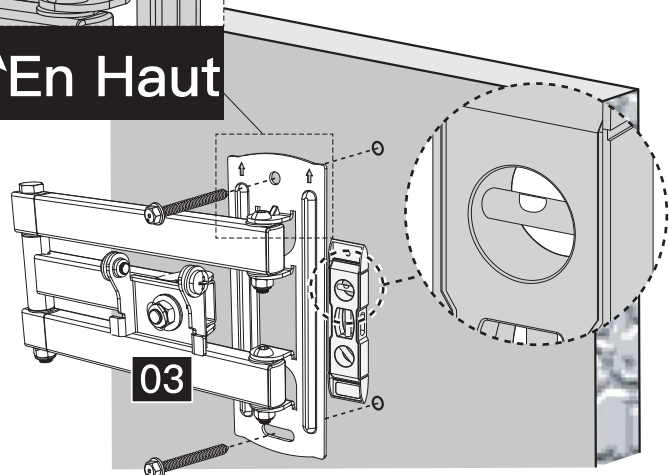

Installez la plaque murale à l'aide des tire-fonds [A1]. Ne serrez les tire-fonds [A1] que jusqu'à ce qu'ils soient fermement tirés contre la plaque murale. **NE SERREZ PAS** trop les tire-fonds [A1].

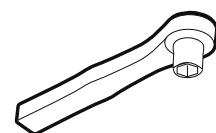
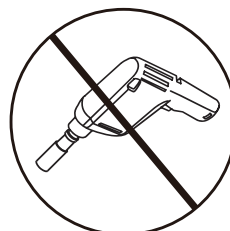

1/2 po (13mm)  
Clé à douille de  
(Non Inclus)

## Matériel fourni pour les étapes 4 et 5

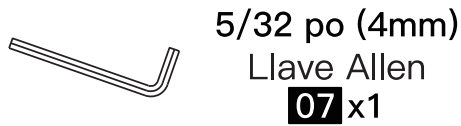

### Étape 4 Fixer le TV sur le bras

4-1 Retirer les boulons préassemblés [T] et les rondelles [W] du bras, et les conserver pour les utiliser à l'étape 4-3.

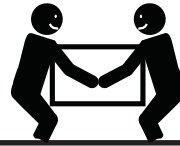
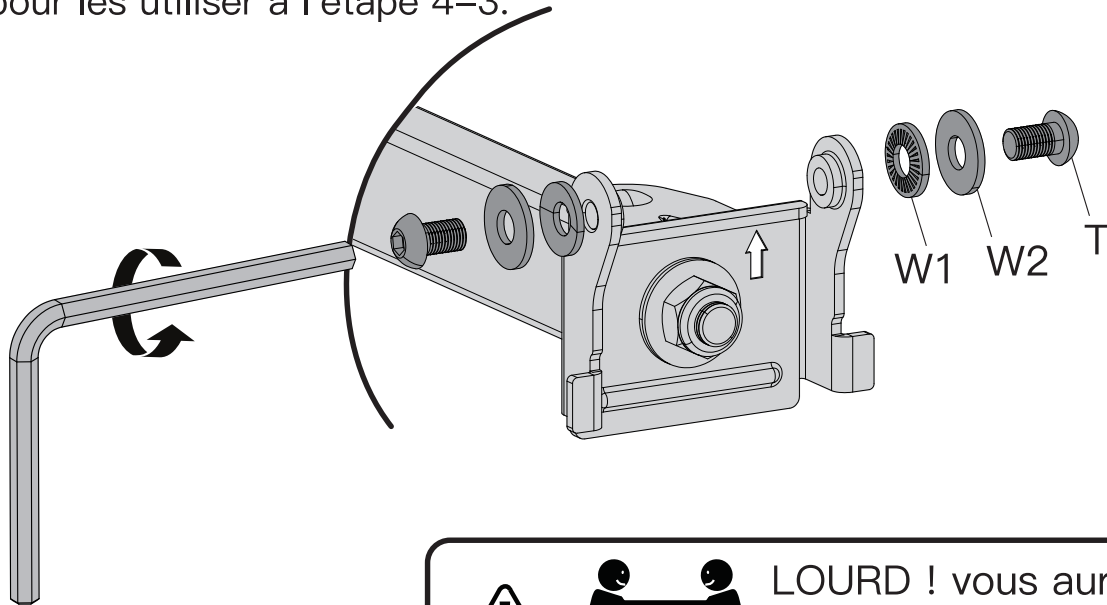

**LOURD !** vous aurez peut-être besoin d'aide pour cette étape.

4-2 Accrocher le TV au bras.

4-3 Tout en maintenant le TV sur le bras, serrer les boulons [T] et les rondelles [W] pour fixer le TV au bras.

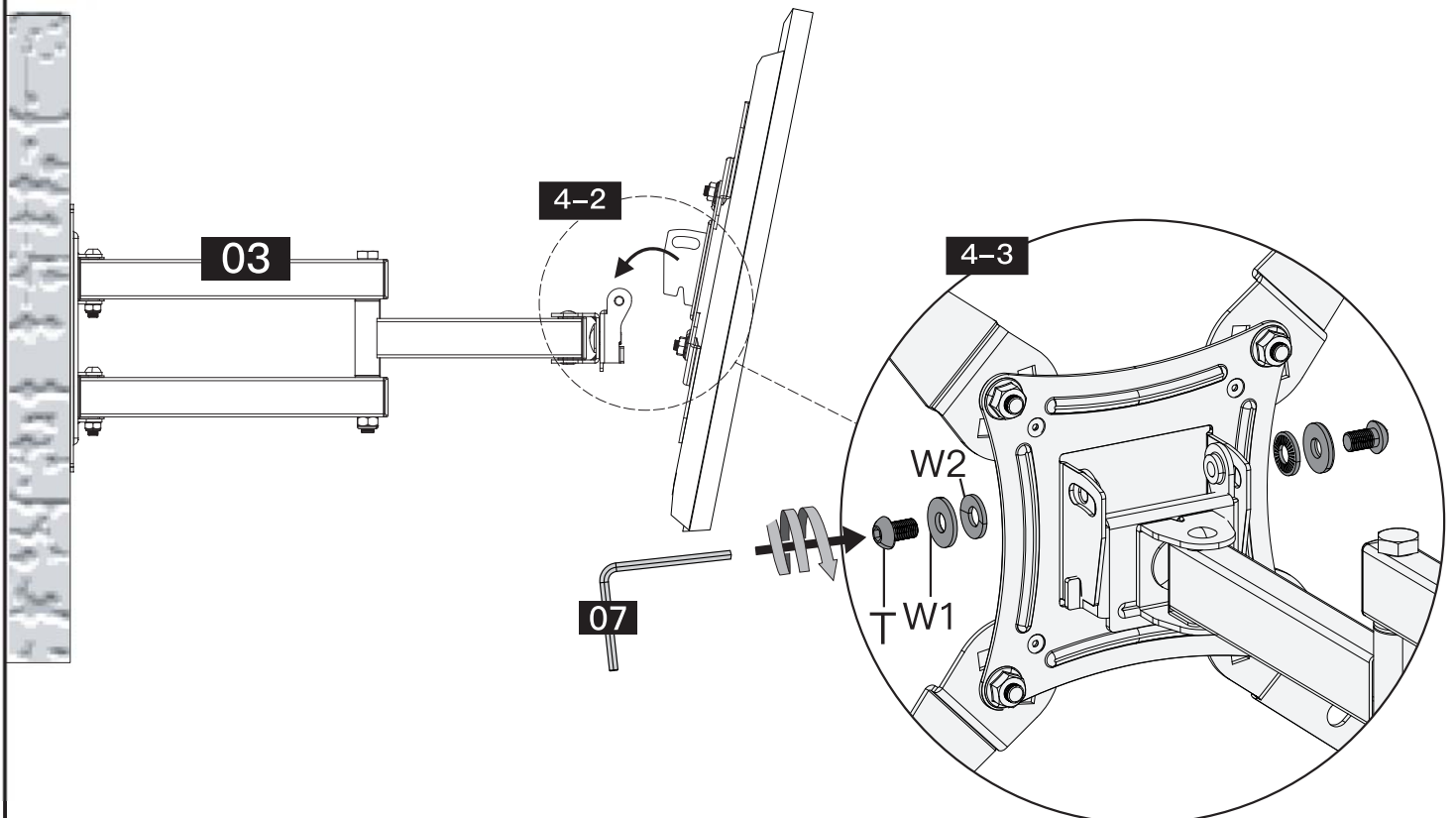

## Étape 5 Réglage de l'inclinaison

1. Desserrez légèrement les deux écrous à bascule [T].
2. Régler le TV selon l'angle d'inclinaison souhaité.
3. Resserrez les deux écrous d'inclinaison [T] pour fixer l'angle d'inclinaison.



5/32 po (4mm)  
Llave Allen  
**07** x1

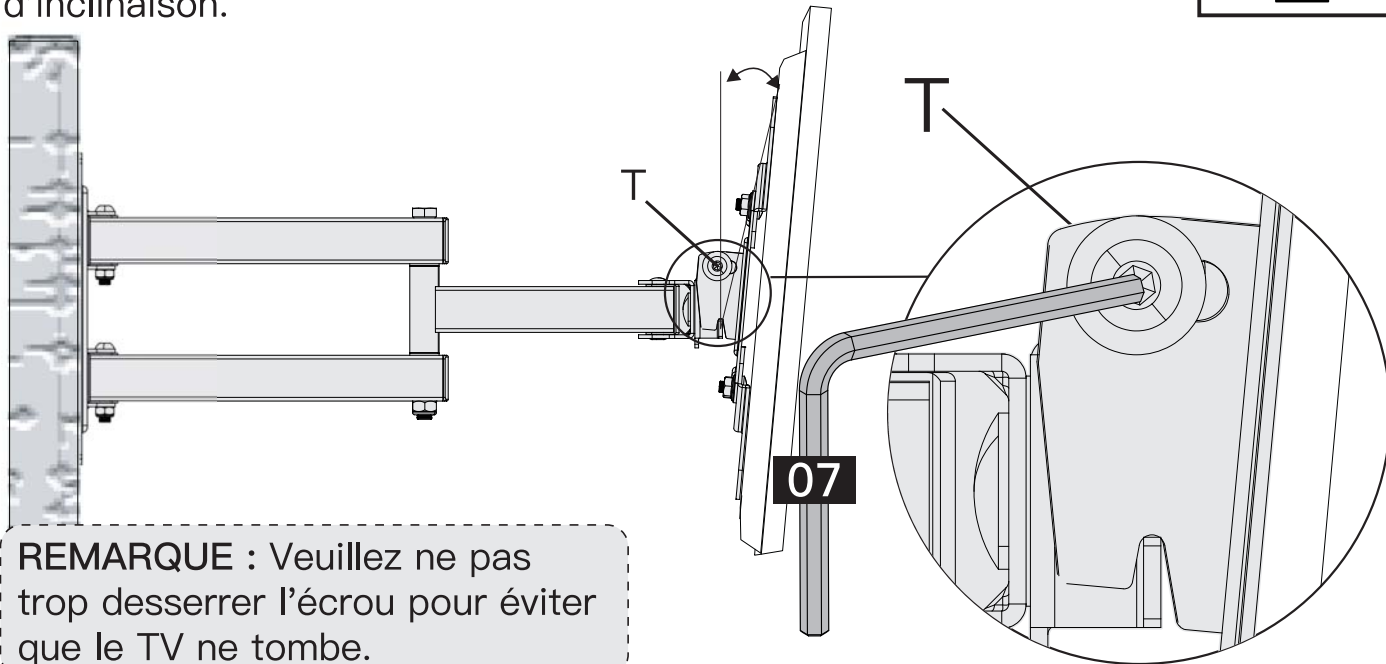

**REMARQUE :** Veuillez ne pas trop desserrer l'écrou pour éviter que le TV ne tombe.

## Étape 6 Réglage du niveau

1. Desserrez légèrement l'écrou préassemblé [L] à l'aide d'une clé.
2. Mettez votre TV à niveau.
3. Resserrez l'écrou préassemblé [L] à l'aide d'une clé pour fixer le TV en place.

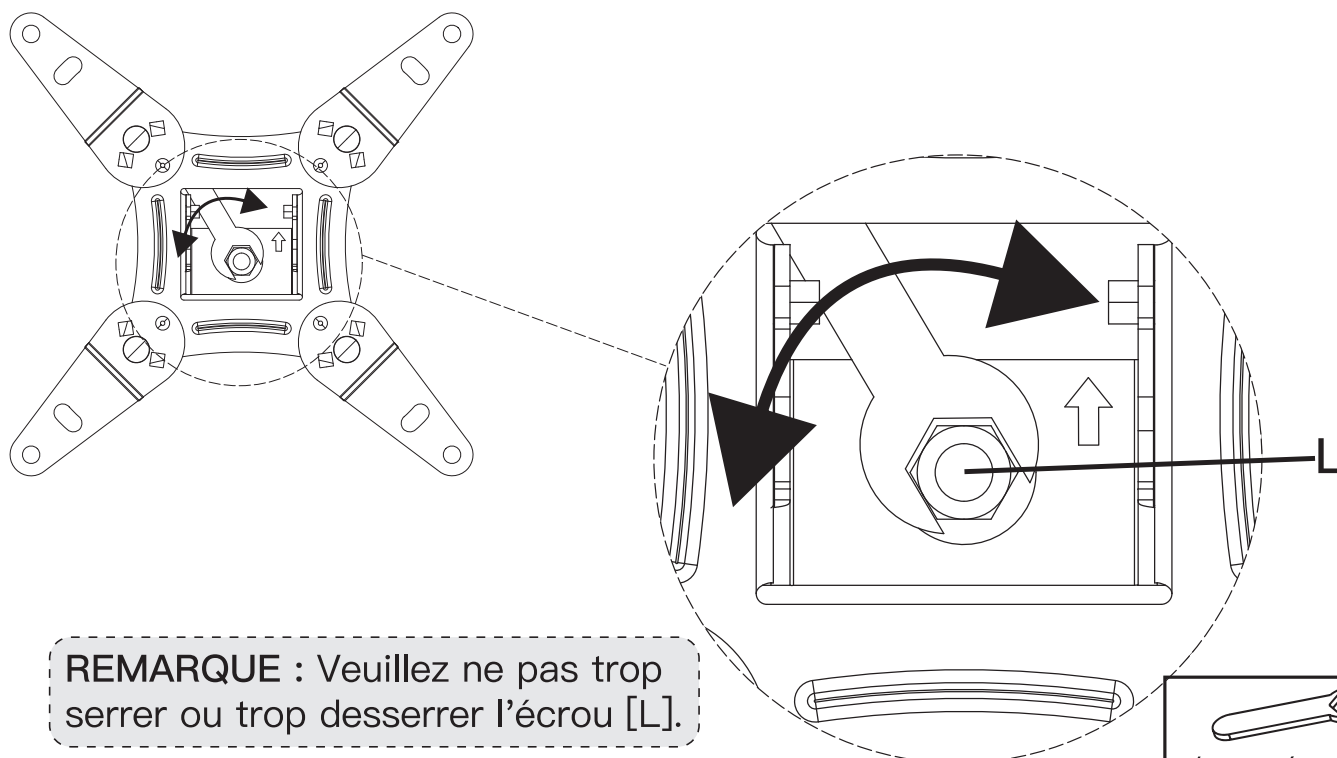

**REMARQUE :** Veuillez ne pas trop serrer ou trop desserrer l'écrou [L].



1/2 po (13 mm)  
Llave inglesa  
(Non Inclus)

## INFORMACIÓN IMPORTANTE DE SEGURIDAD

**⚠ ¡PELIGRO!** Lea todas las instrucciones detenidamente antes de proceder a la instalación. Si no entiende las instrucciones o tiene alguna duda o consulta, póngase en contacto con nuestra línea de asistencia técnica llamando al (877) 419-7832, o escribiendo al servicio de atención al cliente en [support@ergoav.com](mailto:support@ergoav.com).

**⚠ PRECAUCIÓN:** Si se utiliza con productos que sobrepasan los límites máximos indicados de peso es posible que sea inestable y pueda provocar una lesión.

- No utilice este producto con ningún fin que no sea el especificado explícitamente en este manual. No supere la capacidad de peso. No nos hacemos responsables de posibles daños o lesiones causados por un montaje incorrecto, errores de ensamblaje o uso inadecuado.
- Este producto está diseñado para utilizarse en estructura de madera, y en paredes solidas de hormigón. – NO instalar solo en placa de yeso.
- La pared debe poder soportar cuatro veces el peso combinado del TV y el soporte.
- Utilice este sistema de soporte solo según su uso indicado y descrito en estas instrucciones. No use accesorios que no son recomendados por el fabricante.
- No lo use al aire libre.
- Coloque las cuerdas y cables de manera adecuada para no provocar daños mecánicos.
- **GUARDE ESTAS INSTRUCCIONES**

## Límites de peso



Si su TV pesa más, no utilice este producto.

### ⚠ ADVERTENCIA

NO exceda el límite máximo indicado de peso. Solo se puede utilizar este sistema de soporte si se no se sobrepasa los pesos máximos indicados. Si se utiliza con productos que sobrepasan los pesos máximos indicados es posible que el soporte y sus accesorios tengan fallas, y provoquen daños y/o lesiones.

## Revise el patrón VESA de su TV antes de instalarlo.

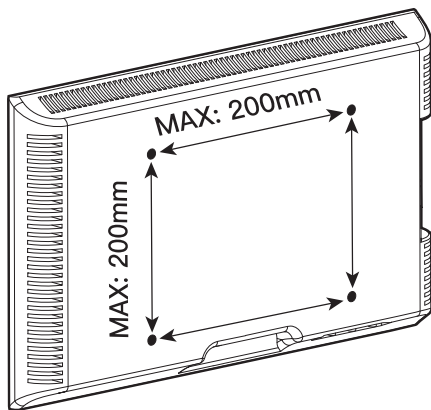

75 mm ≈ 3 pulg  
100 mm ≈ 4 pulg  
200 mm ≈ 7 7/8 pulg

Mínimo: 75mm x 75mm / 3 pulg x 3 pulg (W x H)

Máximo: 200mm x 200mm / 7 7/8 pulg x 7 7/8 pulg (W x H)

Si el patrón VESA de su Televisor es inferior a 75mm x 75mm o superior a 200mm x 200mm, significa que este soporte **NO ES COMPATIBLE**. Póngase en contacto con nuestro Servicio Técnico llamando al (877) 419-7832 o escribiendo a [support@ergoav.com](mailto:support@ergoav.com).

## Herramientas necesarias (no incluidas)



Detector de vigas



Punzón



Cinta de medición



Lápiz

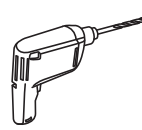

Taladro eléctrico

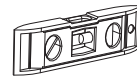

Nivel



Destornillador Philips



Broca para madera de 7/32 pulg (5.5 mm)



Llave de tubo de 3/8 pulg (10 mm)



Llave de tubo de 1/2 pulg (13 mm)

(Necesarios para instalaciones en hormigón)



Broca para hormigón de 3/8 pulg (10mm)



Martillo

## Verifique su construcción de la pared

### ! PRECAUCIÓN

NO instalar solo en placa de yeso

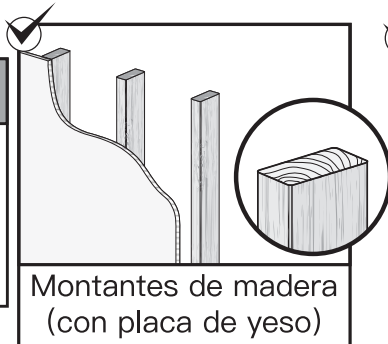

Montantes de madera (con placa de yeso)

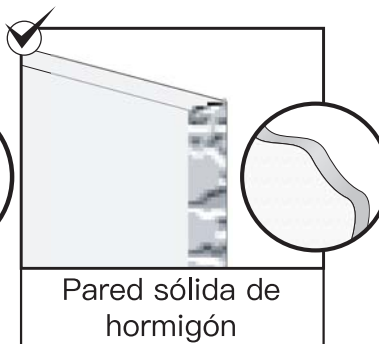

Pared sólida de hormigón

Si no está seguro de la construcción de la pared, póngase en contacto con nuestra línea de asistencia técnica llamando al (877) 419-7832, o comuníquese con nuestro servicio de atención al cliente en [support@ergoav.com](mailto:support@ergoav.com).

## Piezas y herramientas provistas

**! ADVERTENCIA:** Este producto contiene piezas pequeñas que pueden representar un riesgo de atragantamiento si se ingieren.

Antes de iniciar el montaje, compruebe que todas las piezas estén incluidas e intactas. No utilice piezas dañadas o defectuosas. Si necesita piezas de repuesto, póngase en contacto con nuestra línea de asistencia técnica al (877) 419-7832 o con el servicio de atención al cliente en [support@ergoav.com](mailto:support@ergoav.com) para encontrar un soporte compatible.

**TENGA EN CUENTA LO SIGUIENTE:** Es posible que no necesite usar todos los herrajes incluidos en este envase.

## Piezas y herrajes suministrados para el paso 1

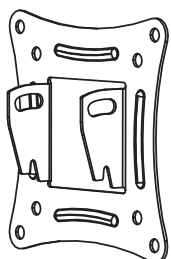

**01** x1  
Placa frontal

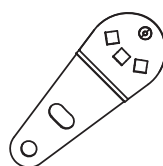

**02** x4  
Soportes extensores

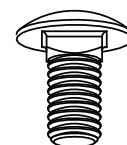

Pernos  
M6 x 12mm  
**[H1] X4**

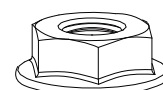

Tuerca  
M6  
**[H2] X4**

## Paso 1 Elija la combinación que se adapte a su modelo de agujeros VESA

Opción A: NO es necesario fijar los soporrtes extensora la placa frontal.  
Consulte a la página 06

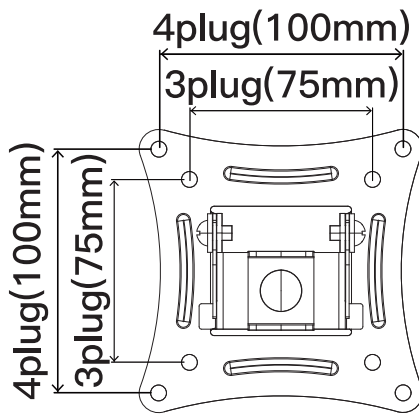

Para el patrón VESA de agujero:  
3 x 3plug/75 x 75mm  
4 x 4plug/100 x 100mm

Opción B: Es necesario fijar los soportes extensora a la placa frontal. Vea las figuras 1 a 3.

### NOTA:

El tope de retención de los soportes extensores [02] debe estar alineado con el agujero de la placa frontal [01].

No ajuste de manera firme los pernos [H1] y tuercas [H2] hasta que el paso 2 se haya completado.

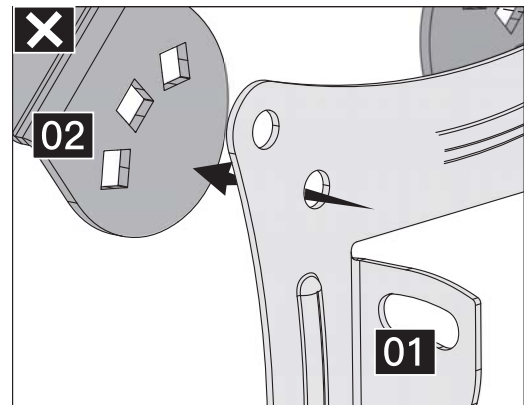
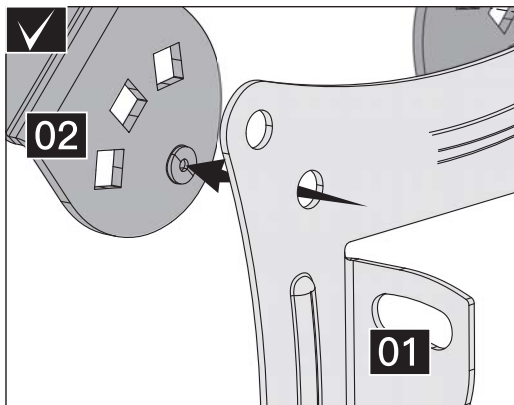

Figuras 1 Para el patrón VESA de agujero: 8 x 8plug/200 x 200mm

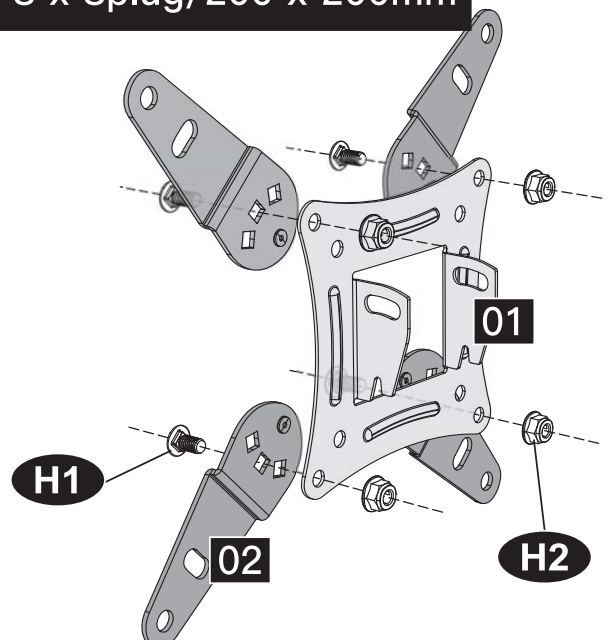
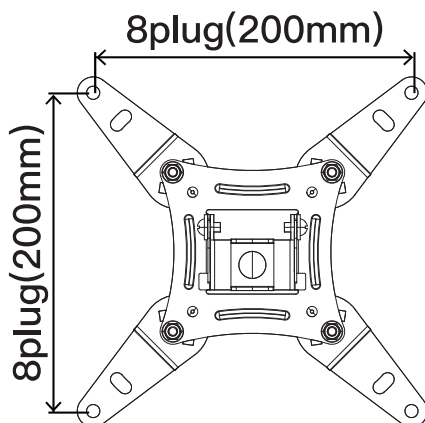



**Figuras 2 Para el patrón VESA de agujero: 4 x 8plug/100 x 200mm**

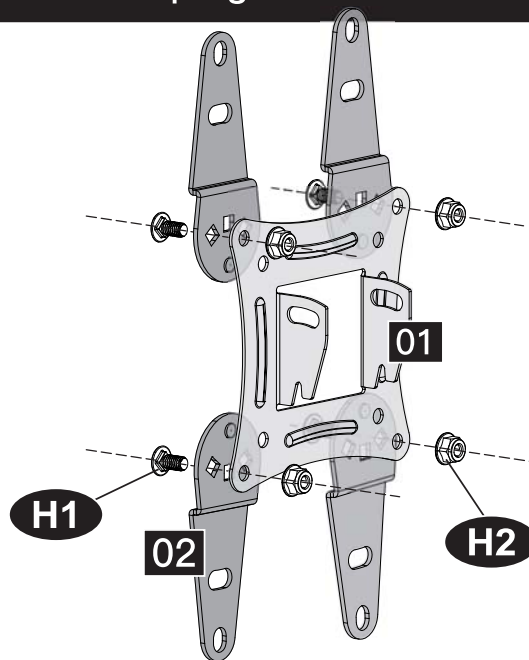
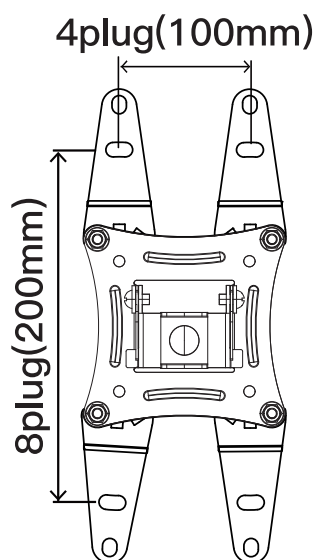

**Figuras 3 Para el patrón VESA de agujero: 8 x 4plug/200 x 100mm**

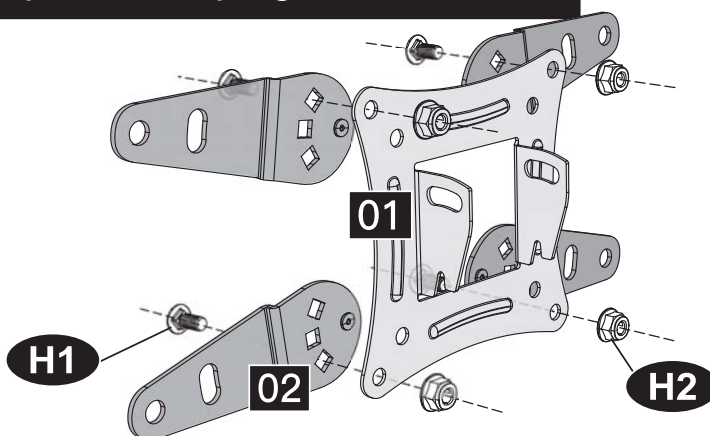
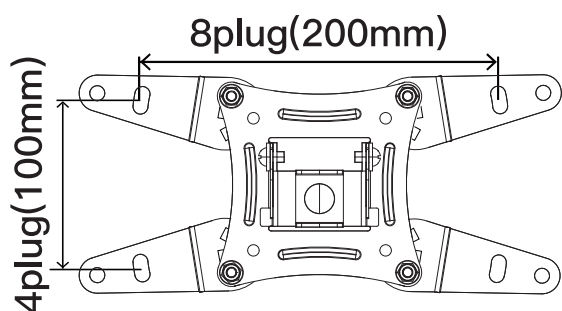

**Piezas y herrajes suministrados para el paso 2**

**04** Arandelas

**05** Espaciadores [si son necesarios]

NOTA: Las arandelas y los espaciadores se muestran a escala real

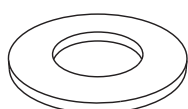
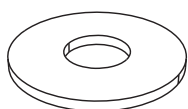

[B1] x4  
M4/M5

[B2] x4  
M6/M8



[G1] x4  
8.5x18x2.5mm

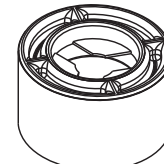

[G2] x8  
8.5x18x10mm

**06** Pernos de TV [Su TV solo admite uno de los tamaños]

NOTA: El tornillo se muestra a escala real

**M4**

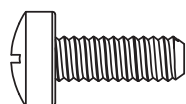

M4 x 12mm  
[C1] x4



M4 x 30mm  
[C2] x4

**M5**



M5 x 25mm  
[D] x4

**M6**

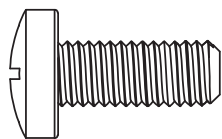

M6 x 15mm  
[E1] x4

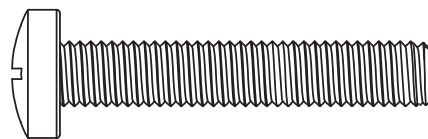

M6 x 35mm  
[E2] x4

**M8**

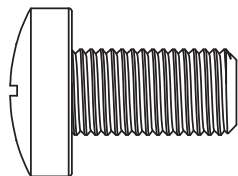

M8 x 15mm  
[F1] x4

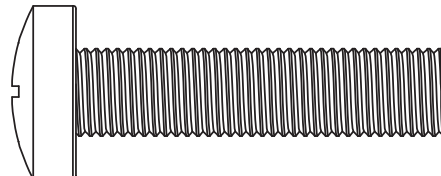

M8 x 35mm  
[F2] x4

## Paso 2 Sujete los soportes del TV al TV

### Seleccione los Pernos de TV

Su TV solo admite uno de los tamaños.

M4

M5

M6

M8

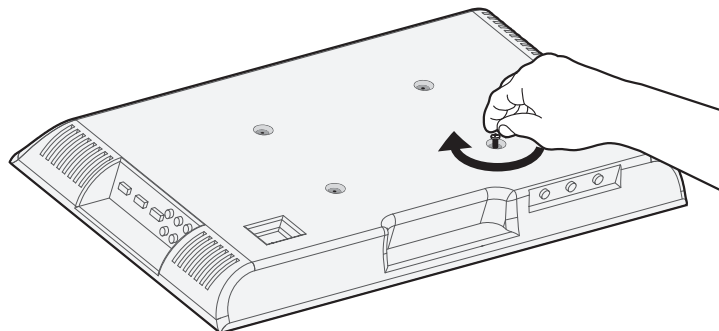
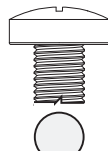

**NOTA:** No ajuste demasiado los pernos de TV para evitar daños a su TV.

Longitud del tornillo: Compruebe que la rosca encaje correctamente con los tornillos o la las combinaciones de tornillo/espaciador. Se recomienda enganchar las roscas con 5 vueltas como mínimo.

- Demasiado corto, no sostendrá el TV.
- Demasiado largo, dañará el TV.

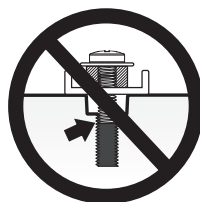

Demasiado corto

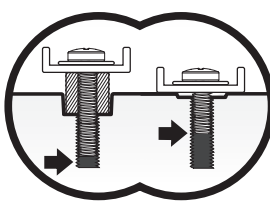

Correcto

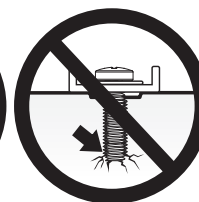

Demasiado largo

**TENGA EN CUENTA LO SIGUIENTE:** Al utilizar espaciadores, es importante tener en cuenta que se pueden utilizar apilados. Si tiene alguna dificultad para comprender el modo de instalación de los pernos o espaciadores del TV, póngase en contacto con nuestra línea de asistencia técnica al (877) 419-7832 o con el servicio de atención al cliente en [support@ergoav.com](mailto:support@ergoav.com).

# Piezas necesarias si tiene un TV como el que se muestra a continuación

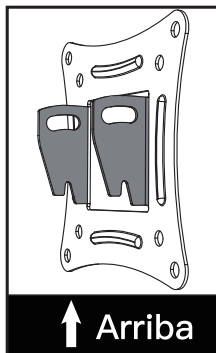
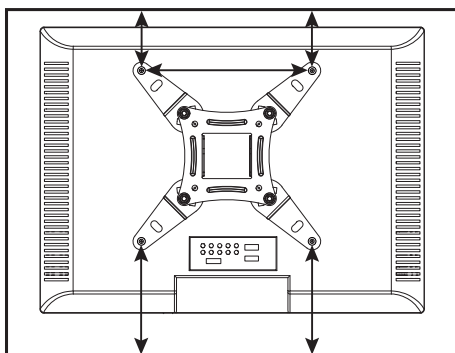
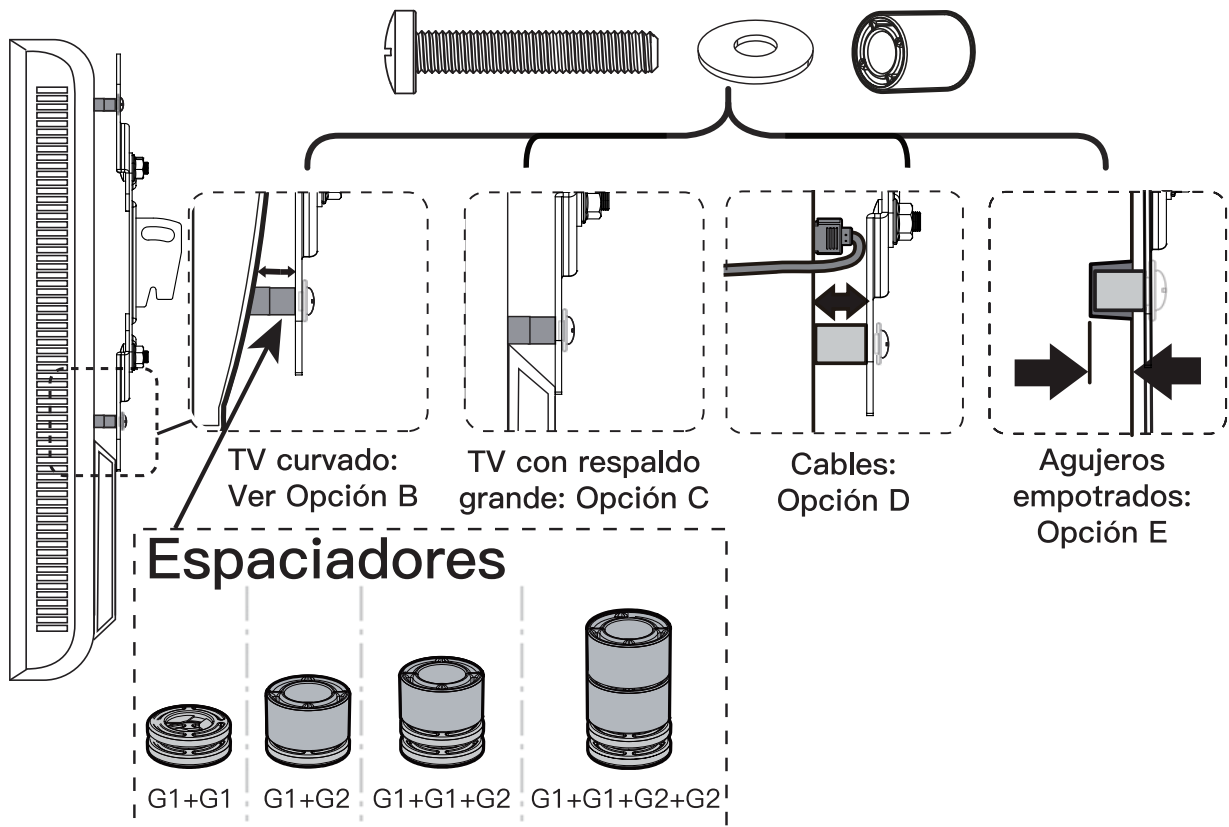

⚠ Cuando fije la placa frontal a la parte trasera del TV, asegúrese de que los ganchos que apuntan hacia abajo, apunten a la parte inferior del TV y que la placa frontal esté centrada de manera pareja en la parte trasera del TV.

⚠ **TENGA EN CUENTA LO SIGUIENTE:** Las ubicaciones de los agujeros para tornillos del TV pueden variar según el diseño del TV por parte del fabricante. Solo ilustramos algunas ubicaciones posibles de dichos agujeros.

## Opción A (para TV con respaldo plano)

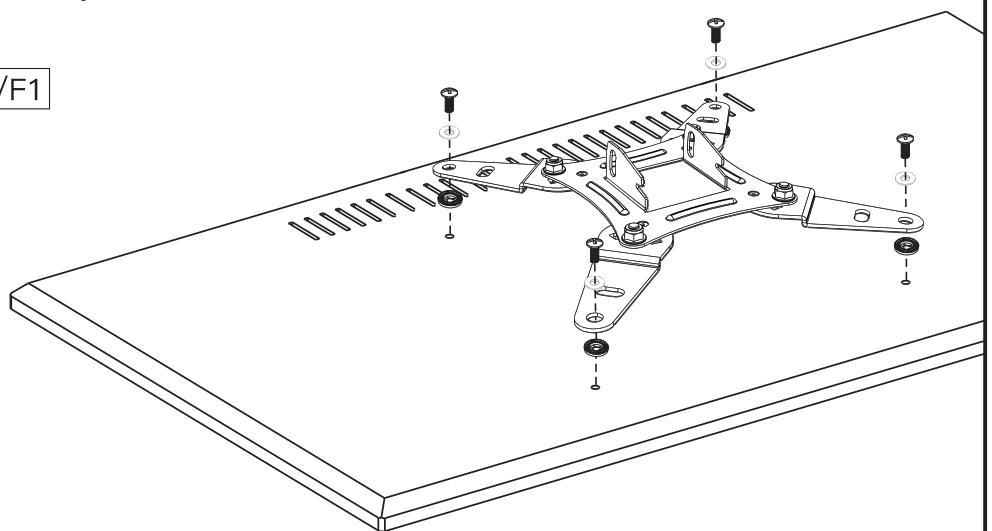
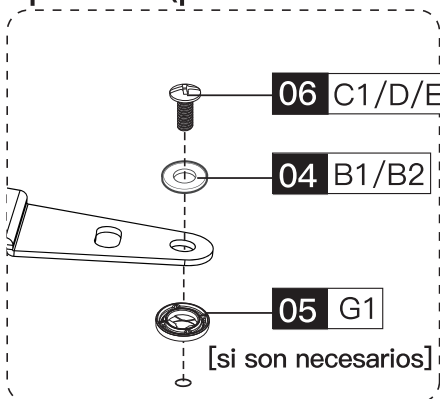

### Opción B (para TV con respaldo curvo)

Los espaciadores deben ser lo suficientemente altos para que la curva de la parte posterior del TV no interfiera con la placa de montaje.

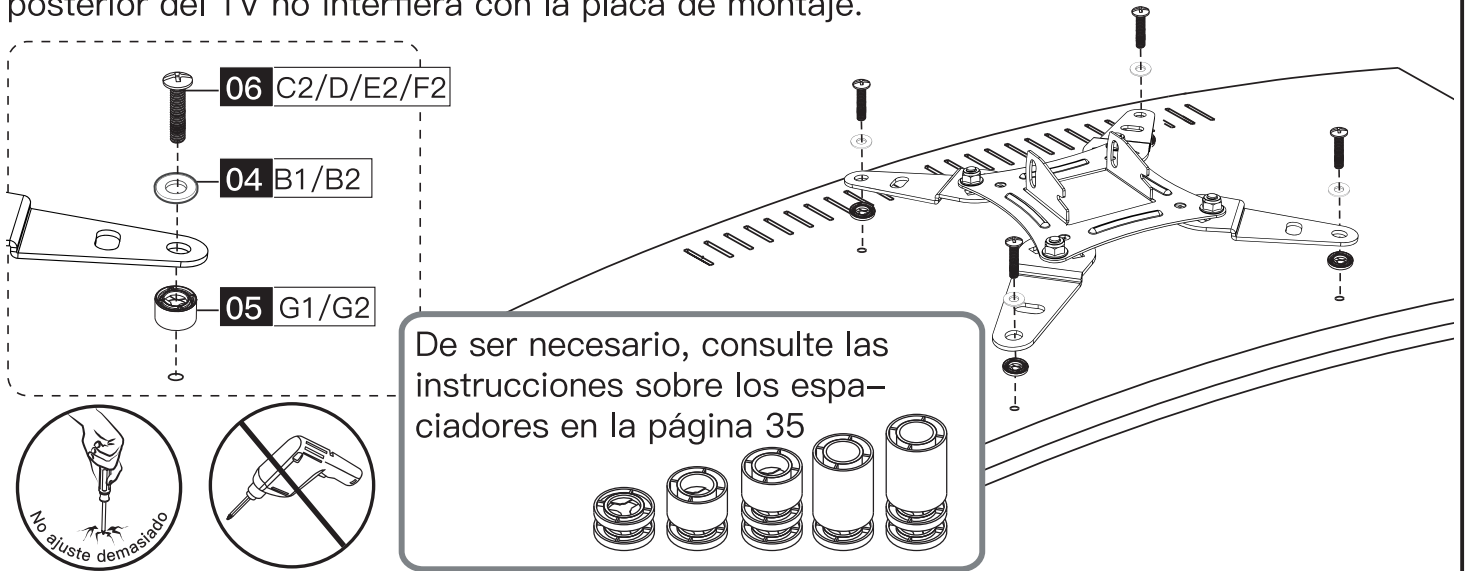

### Opción C (para TV con un respaldo grande)

Los espaciadores deben estar lo suficientemente alto para que no haya espacio entre la placa frontal y la parte trasera del Televisor.

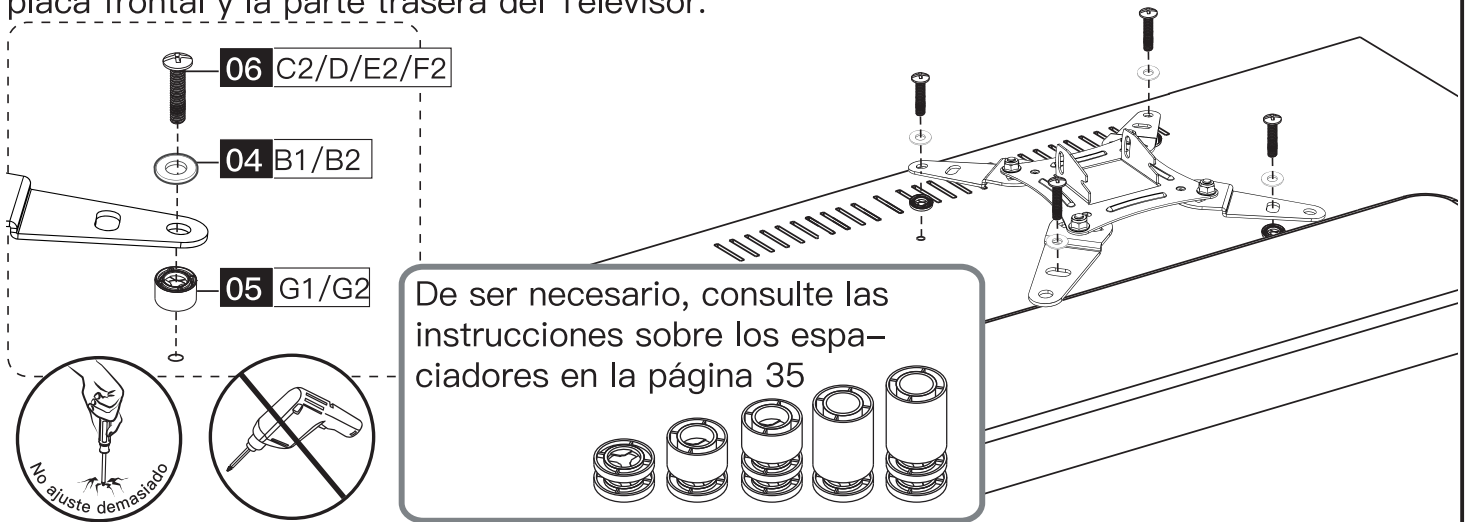

### Opción D (para interferencia de cable)

En caso de interferencias con los cables utilice los espaciadores 05 para crear extra espacio entre el Televisor y la placa frontal.

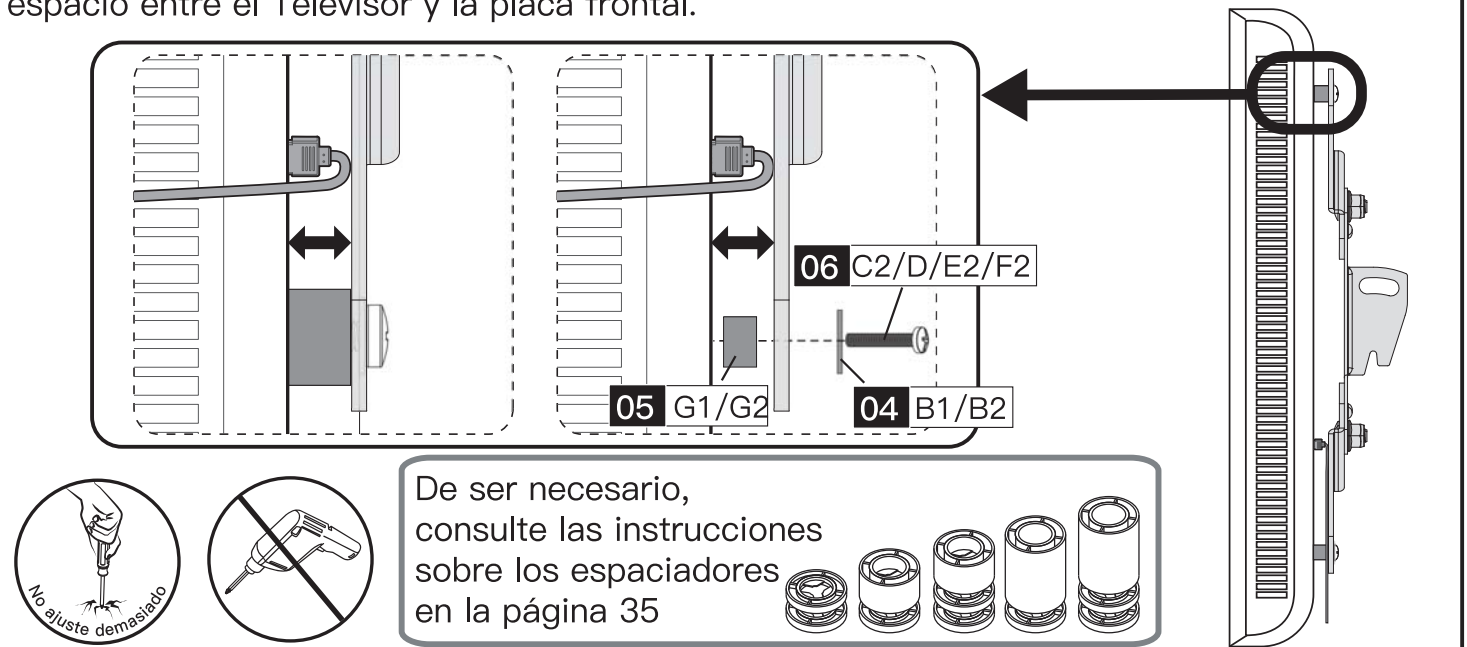

## Opción E (para agujeros empotrados)

El espaciador debe encajar en los agujeros empotrados en la parte trasera del TV para que los placa frontal estén lo más cerca posible del mismo.

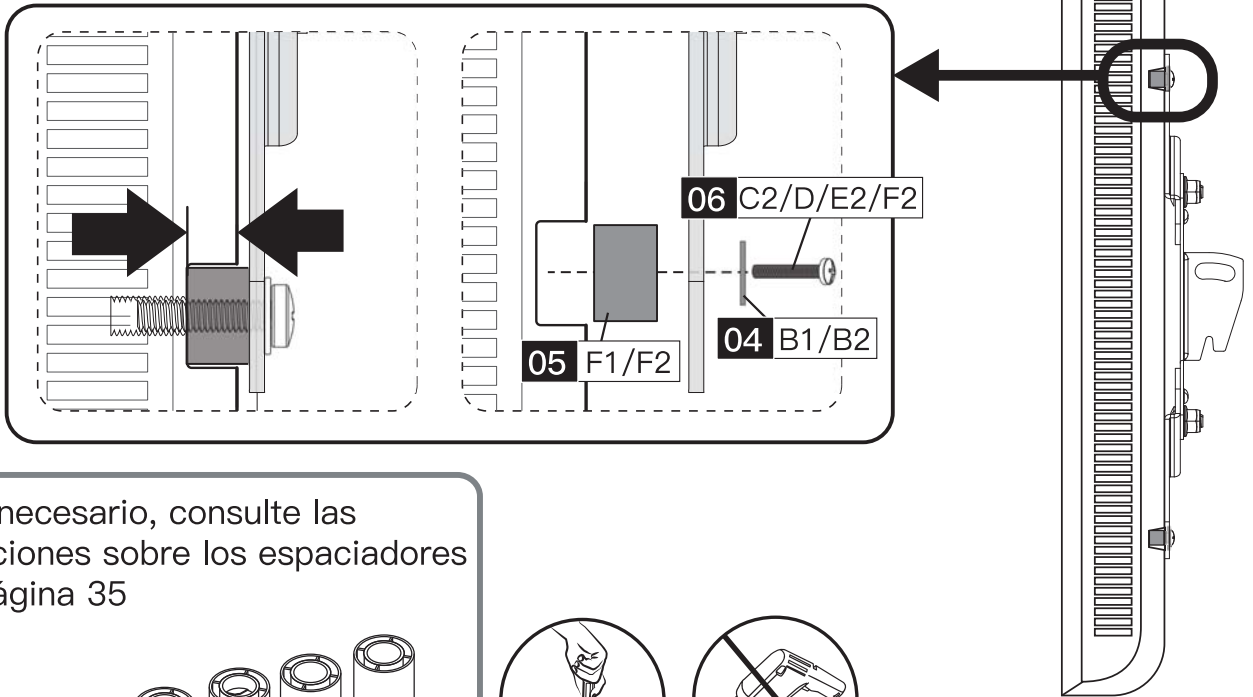

De ser necesario, consulte las instrucciones sobre los espaciadores en la página 35

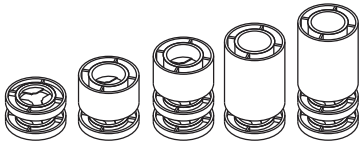

**!** Cuando termine de asegurar los Pernos de TV en el televisor, recuerde ajustar las tuercas [H2] usando una llave de tubo.

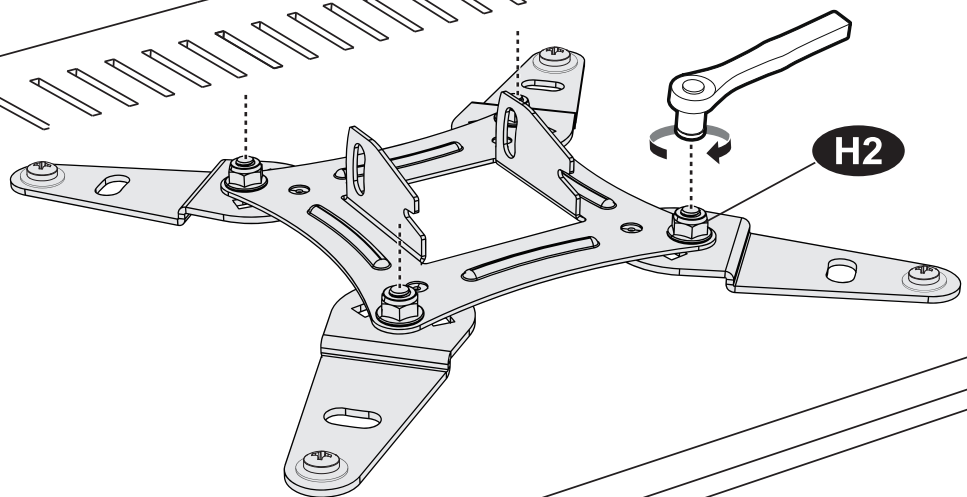

3/8 pulg (10mm)  
Llave de tubo  
(no incluidas)

## Piezas y herrajes suministrados para el paso 3

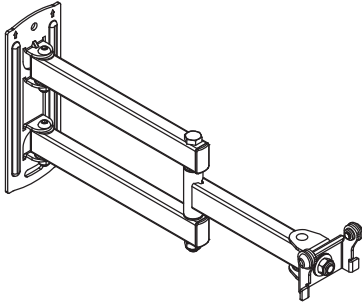

**03** x1

Conjunto de brazo/  
placa de pared

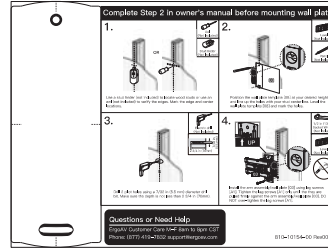

**08** x1

Plantilla de Placa  
de Pared

**A1**

x2

Tornillo de retraso  
5/16 x 2 3/4 pulg

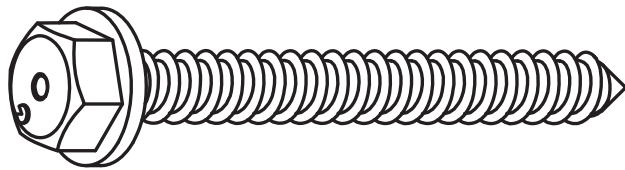

**A2**

x2

Anclas de pared  
10 x 60mm

**! ¡PRECAUCIÓN!**

Esta ancla es SOLO para  
paredes de hormigón. NO  
los utilice en paredes de  
yeso o estructuras de  
madera.

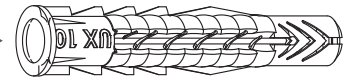

### Paso 3 Fije el Conjunto de brazo/placa de pared [03] a la pared

Para una instalación de estructura de madera, siga el PASE 3A

Para una instalación de hormigón siga el PASO 3B

#### Paso 3A Opción de estructura de madera

##### **! ADVERTENCIA:**

No utilice un taladro para ajustar los tornillos de retraso. Utilice únicamente una llave de tubo.

¡Evite posibles lesiones personales y daños materiales! NO ajuste demasiado los tornillos de retraso [A1]. Solo ajuste los tornillos de retraso [A1] hasta que estén estirados de manera firme contra la placa de pared.

**NO UTILICE EL ANCLA EN ESTE PASO.**

Asegúrese que la placa de pared esté ajustada de manera segura a la pared antes de seguir con el siguiente paso.



- Tamaño nominal de las estructuras de madera: común 2x4 pulg (51x102 mm)
- Se debe verificar el centro de la estructura.

### 3A-1

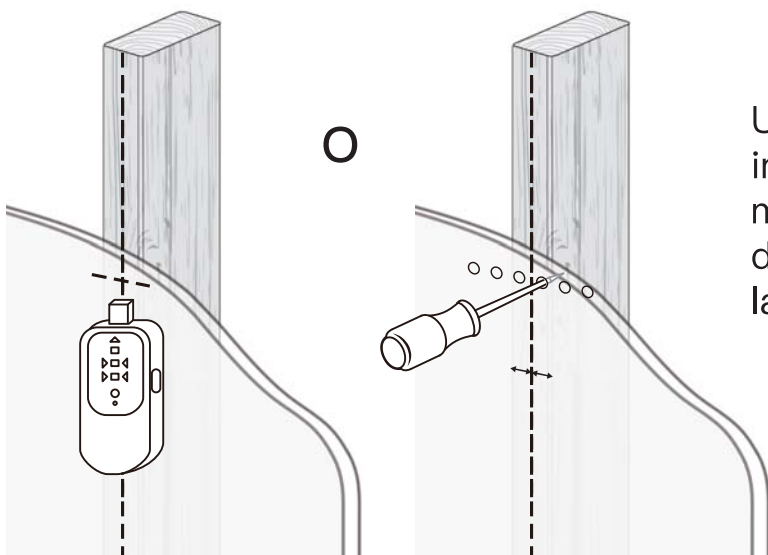

Utilice un buscador de estructura (no incluido) para ubicar las estructuras de madera o utilice un punzón (no incluido) para verificar los bordes. Marque las ubicaciones del borde y el centro.

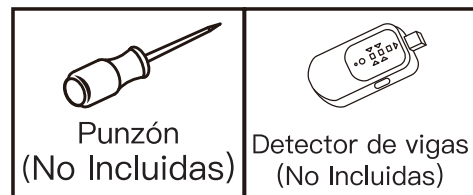

### 3A-2

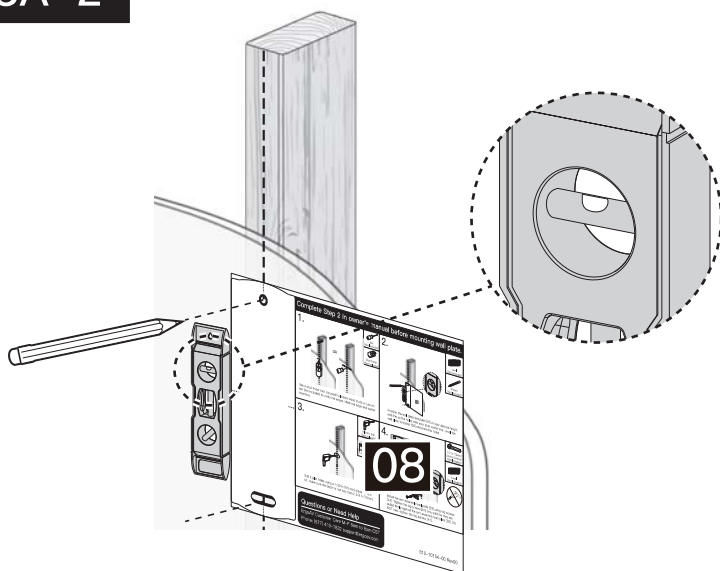

Coloque la plantilla de placa de pared [08] a la altura que desee y alinee los agujeros con su línea central de la estructura. Nivele la plantilla de placa de pared [08] y marque los agujeros.

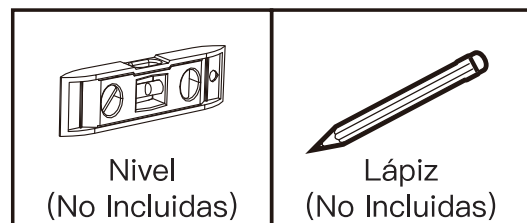

### 3A-3

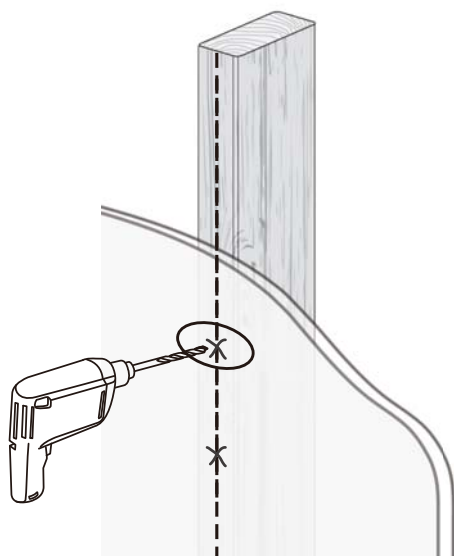

Taladre 2 agujeros piloto usando una broca de 7/32 pulg (5.5 mm) de diámetro. Asegúrese que la profundidad no sea menor a 2 3/4 pulg (70 mm).

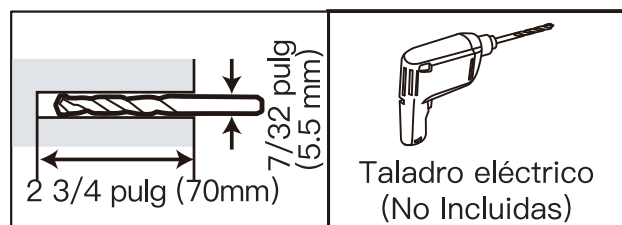

### 3A-4

NOTA: No utilice el taladro para ajustar los tornillos de retraso Solo utilice una llave de tubo.

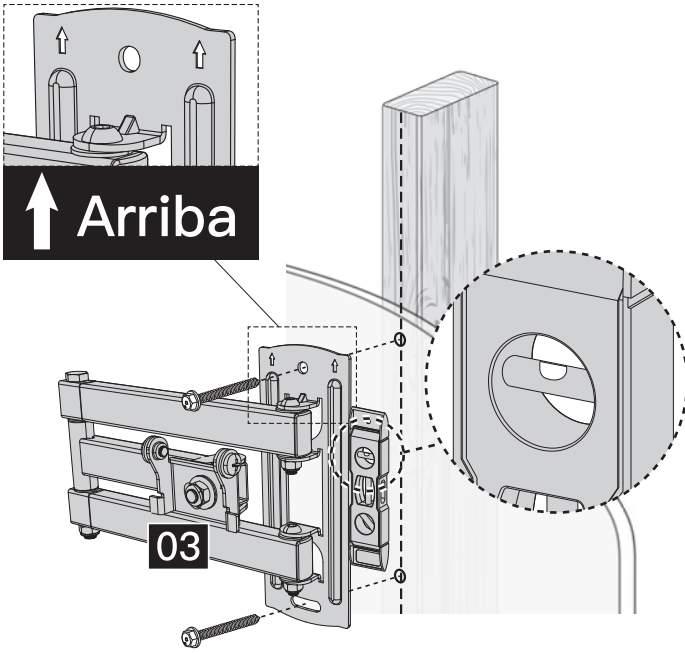

Instale el conjunto de brazo/placa de pared [03] usando los tornillos de retraso [A1]. Solo ajuste los tornillos de retraso [A1] hasta que estén estirados de manera firme contra el conjunto de brazo/placa de pared [03]. NO ajuste demasiado los tornillos de retraso [A1].

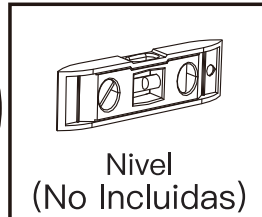
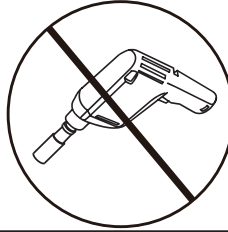

## Paso 3B Opción de pared sólida de hormigón

### ⚠ Advertencia:

● ¡Evite posibles lesiones personales y daños materiales! NO ajuste demasiado los tornillos de retraso [A1]. Solo ajuste los tornillos de retraso [A1] hasta que estén estirados de manera firme contra la placa de pared.

● Asegúrese que la placa de pared esté ajustada de manera segura a la pared antes de seguir con el siguiente paso.

● Monte la placa de pared de manera directa en la superficie de hormigón sin ninguna cubierta.

● La densidad de la pared de hormigón debe superar las 5.5 pulg (140 mm). ¡No utilice el taladro para ajustar los tornillos de retraso! Solo utilice una llave de tubo.



Anclas de pared

**A2**

### 3B-1

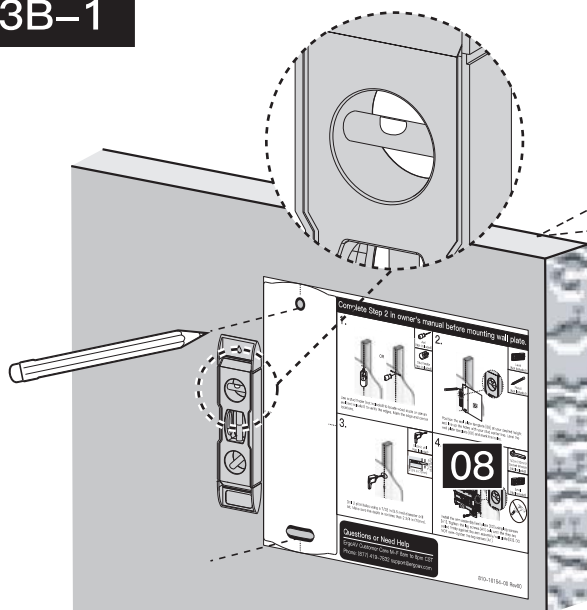

Coloque la plantilla de placa de pared [08] a la altura que desee, nivele la plantilla de placa de pared [08] y marque las ubicaciones de los agujeros piloto.



### 3B-2

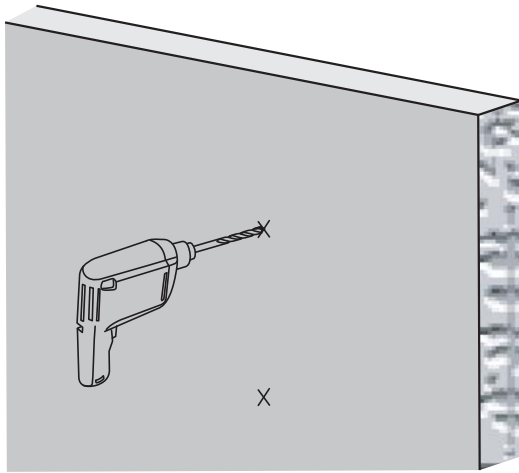

Taladre 2 agujeros piloto usando una broca de 3/8 pulg (10 mm) de diámetro. Asegúrese que la profundidad no es menor a 3 pulg (75 mm).

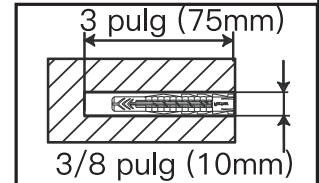

### 3B-3

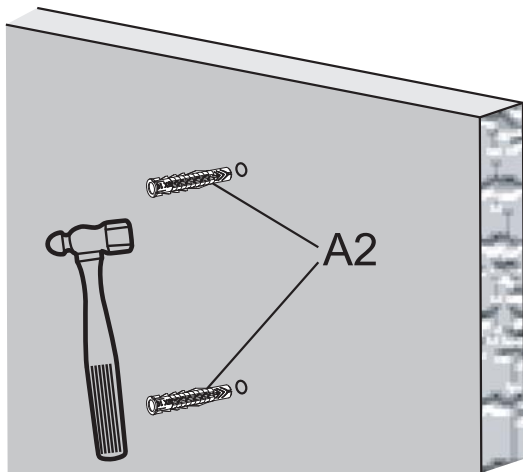

Utilice el martillo para empujar las anclas [A2] hacia la pared. Asegúrese que las anclas [A2] estén fijadas al ras con la superficie de hormigón.

### 3B-4

NOTA: No utilice el taladro para ajustar los tornillos de retraso Solo utilice una llave de tubo.

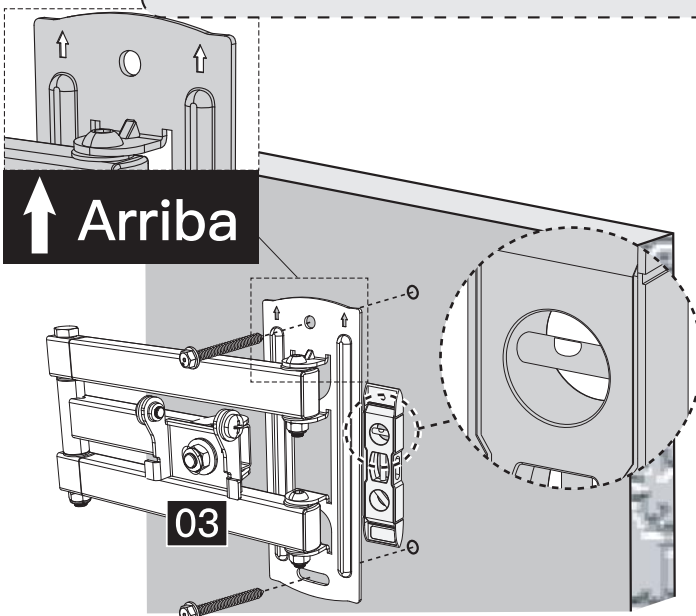

Instale la placa de pared utilizando tornillos de retraso [A1]. Solo ajuste los tornillos de retraso [A1] hasta que estén estirados de manera firme contra la placa de pared. NO ajuste demasiado los tornillos de retraso [A1].

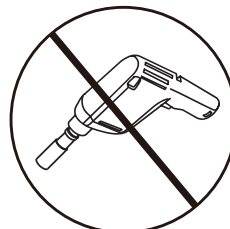

## Herramientas incluidas para el Paso 4 y 5

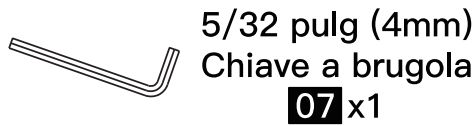

### Paso 4 Asegure el TV al brazo

4-1 Retire los pernos ya fijados [T] y las arandelas [W] del brazo, y guárdelos para utilizarlos en el paso 4-3.

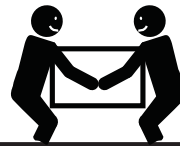
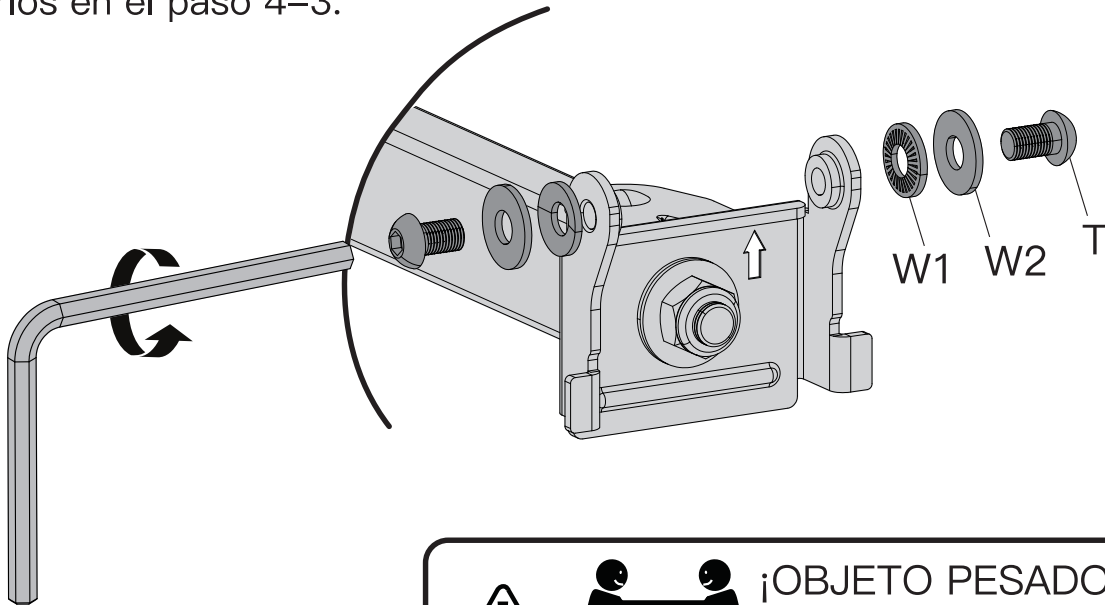

**¡OBJETO PESADO!** Es posible que necesite asistencia en este paso.

4-2 Cuelgue el TV en el brazo.

4-3 Mientras sostiene el TV en el brazo, ajuste los pernos [T] y las arandelas [W] para asegurar el TV al brazo.

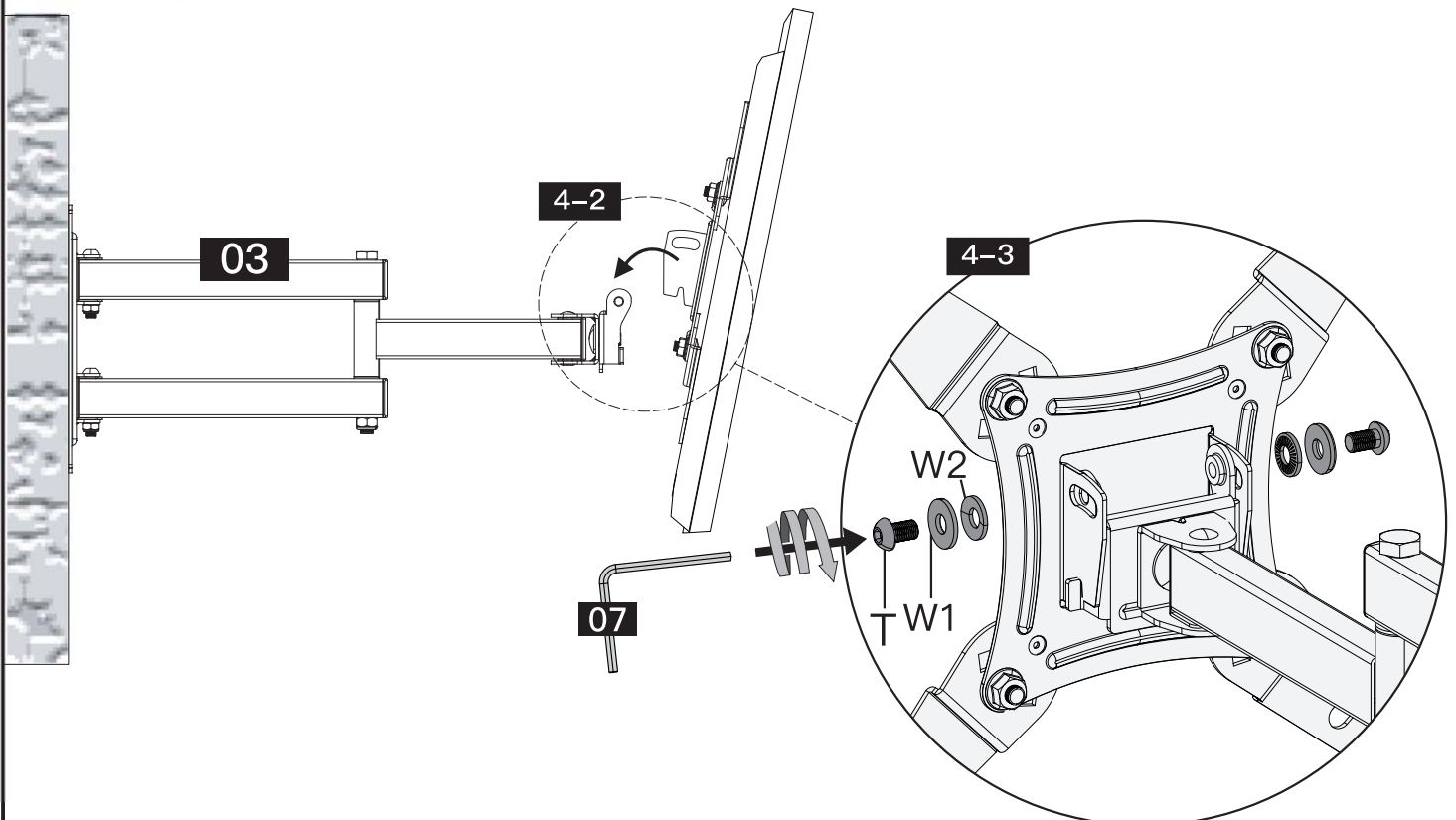

## Paso 5 Ajuste de inclinación

1. Afloje de manera ligera las dos tuercas de inclinación [T].
2. Ajuste su TV al ángulo que desee.
3. Vuelva a ajustar las dos tuercas de inclinación [T] para fijar el ángulo de inclinación.

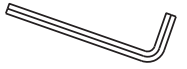
  
5/32 pulg (4mm)  
Chiave a brugola  
**07** x1

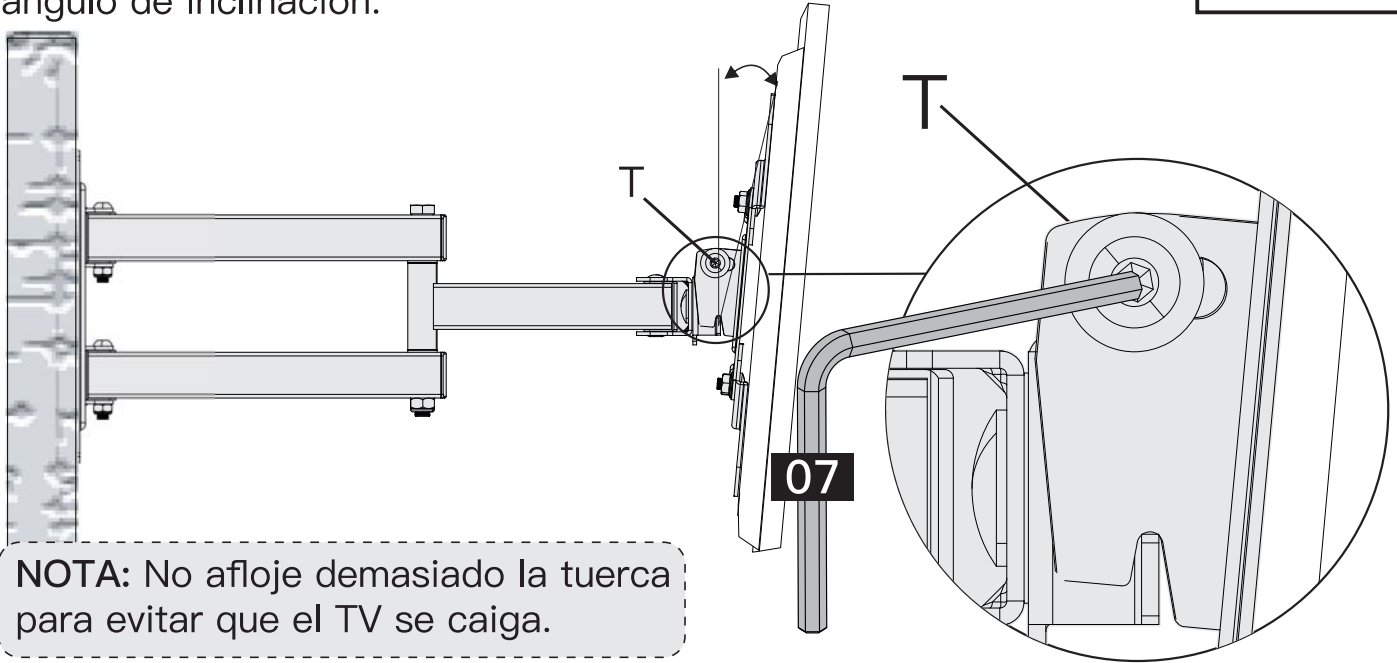

## Paso 6 Ajuste de nivel

1. Afloje ligeramente la tuerca preensamblada [L] con una llave.
2. Nivele su televisor.
3. Vuelva a apretar la tuerca preensamblada [L] con una llave para fijar el televisor en su lugar.

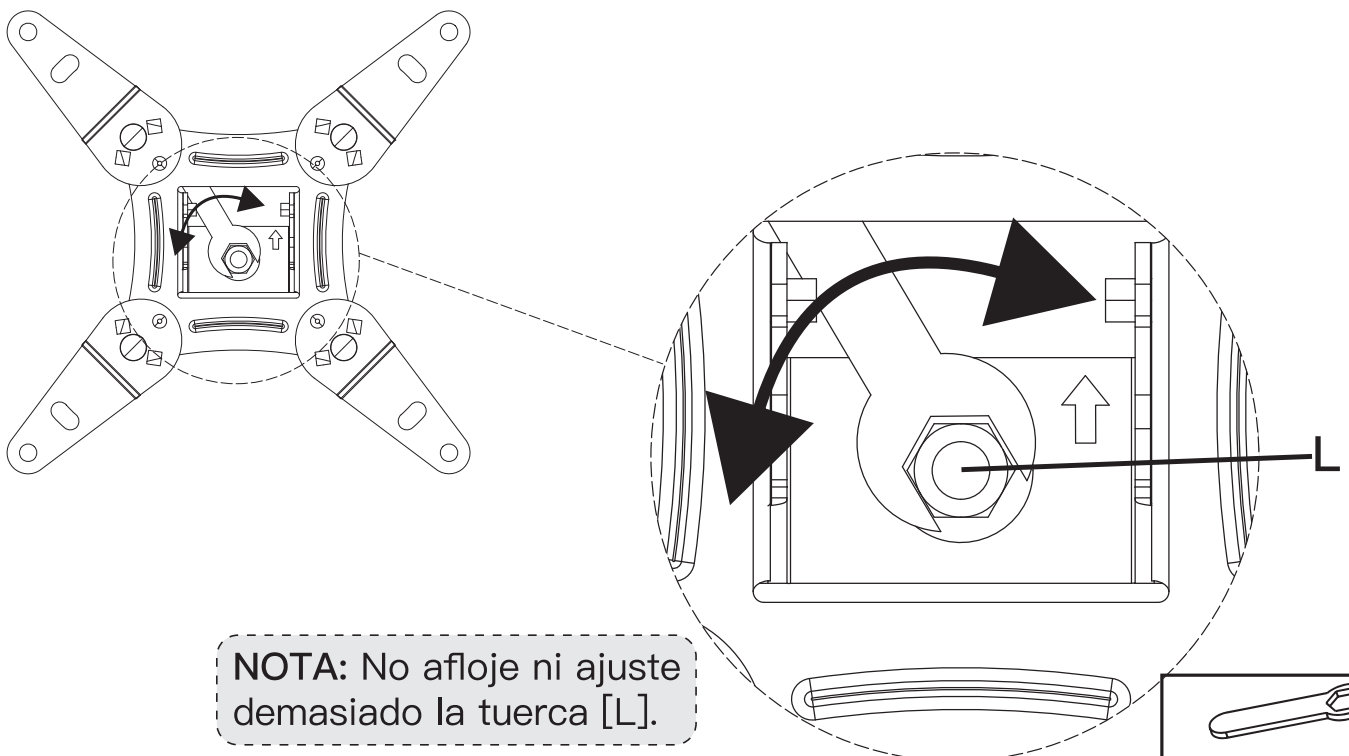

  
1/2 pulg (13 mm)  
Chiave inglese  
(No Incluidas)



At ErgoAV, we strive to provide the highest value products.  
We want to support your purchase.  
If you have questions, concerns,  
or feedback please let us know!

ErgoAV Customer Care  
Phone (877) 419-7832  
[support@ergoav.com](mailto:support@ergoav.com)

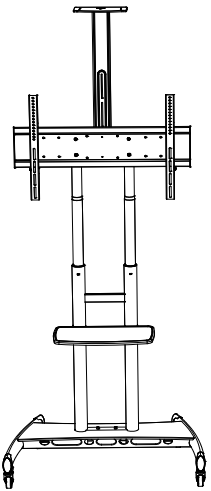

TV Carts

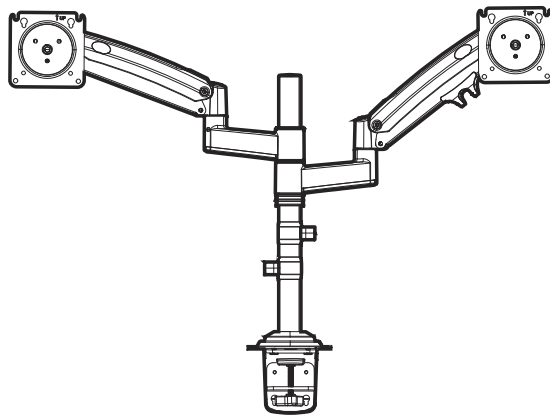

Computer Monitor Mounts

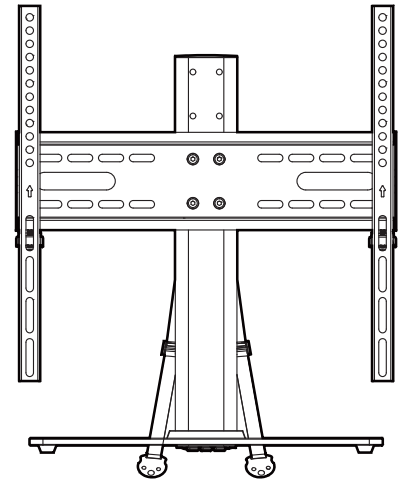

Tabletop TV Stands

9501 Louisiana Ave N, #200, Brooklyn Park, MN 55445

[www.ergoav.com](http://www.ergoav.com)