



Drawer Cabinet Instruction Manual

V0

English 01-10

Français 11-20

Español 21-30

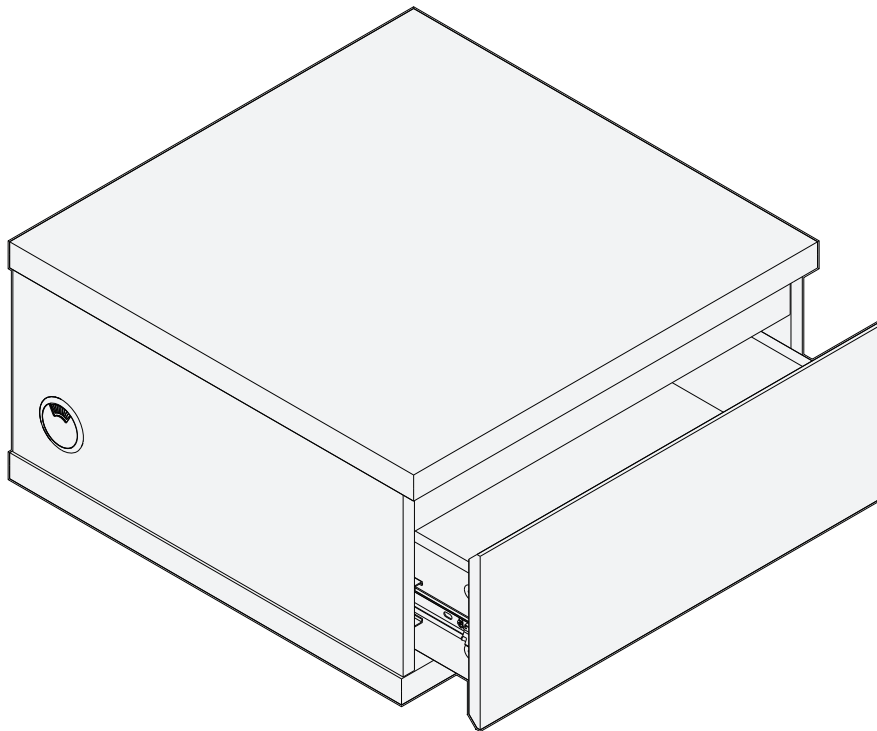

ERFM3

Thank you for choosing ErgoAV!

At ErgoAV, our goal is to add value to your AV experience by providing the highest quality products and services in the industry. If you have any questions or concerns, please contact us.

 **ErgoAV**  **9501 Louisiana Ave N, #200, Brooklyn Park, MN 55445**

 **(877) 419-7832 Mon-Fri 8am - 8pm (CST)**  **www.ergoav.com**

 **support@ergoav.com**

Important Safety Information

⚠ DANGER: Please carefully read all instructions before attempting installation. If you DO NOT understand the instructions or have any questions or concerns, please call technical support or email customer service.

⚠ CAUTION: Avoid the risk of personal injury and property damage!

- DO NOT use this product for any purpose that is NOT explicitly specified in this manual. DO NOT exceed the maximum weight capacity. We are not liable for damage or injury caused by incorrect assembly, improper mounting, or inappropriate use.

- The information contained in this manual DOES NOT cover all possible conditions or variables in relation to the installation of this product. The information provided in this document is subject to change without notice.

⚠ WARNING: Children have died from furniture tipover. To reduce the risk of furniture tipover:

- ALWAYS install tipover restraint provided.
- NEVER exceed the maximum weight capacity in the instructions.
- NEVER allow children to stand, climb or hang on drawers, doors, or shelves.
- NEVER open more than one drawer at a time.
- Place heaviest items in the lowest drawers, shelves or cabinets.
- Do Not stack more than two units. When two units are stacked, secure the units tightly using the stacking connector and thumb screws.
- Never allow stacked cabinets' height to exceed 31 inches from the floor.

Product Specifications

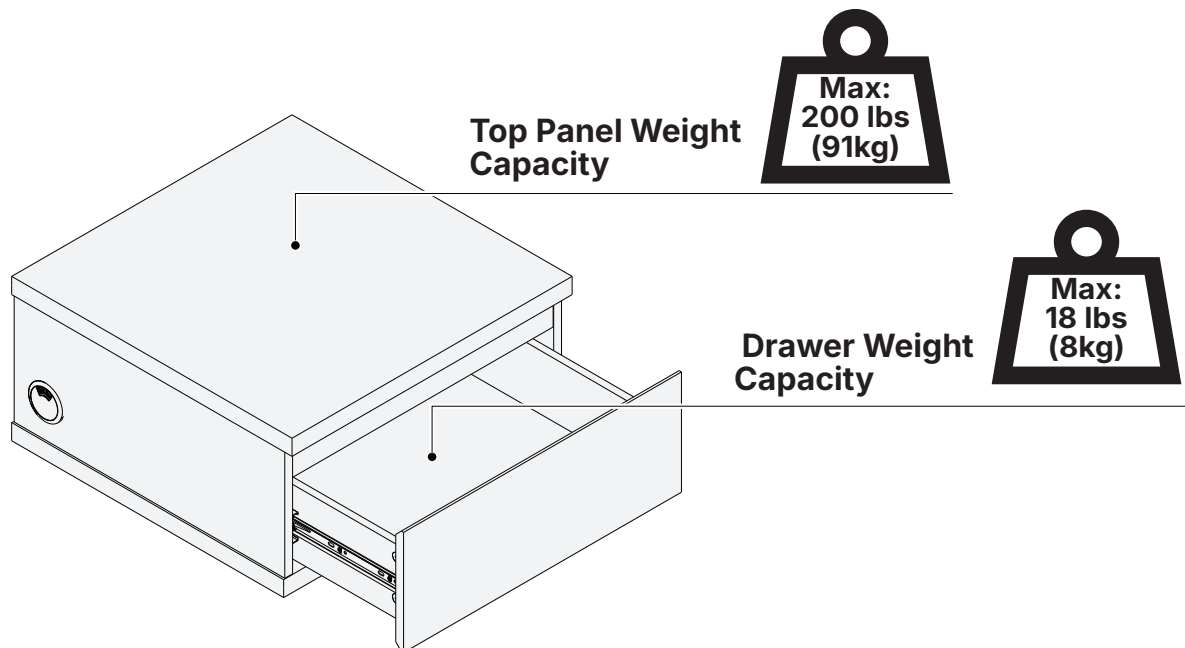

⚠ WARNING

DO NOT exceed the maximum weight indicated. This cabinet is intended for use only within the weight ranges listed. Use with products heavier than the maximum weight limit may result in failure of the cabinet, causing potential damage and or injury. DO NOT exceed the specified weight limits.

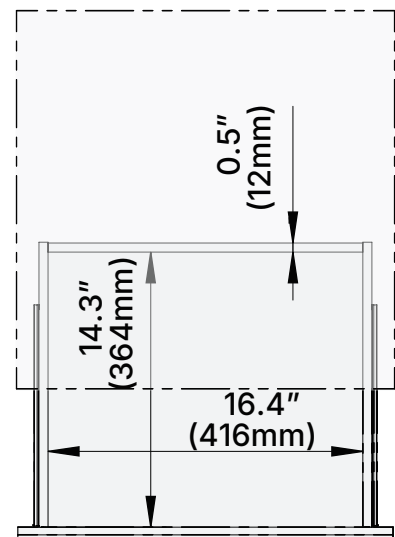
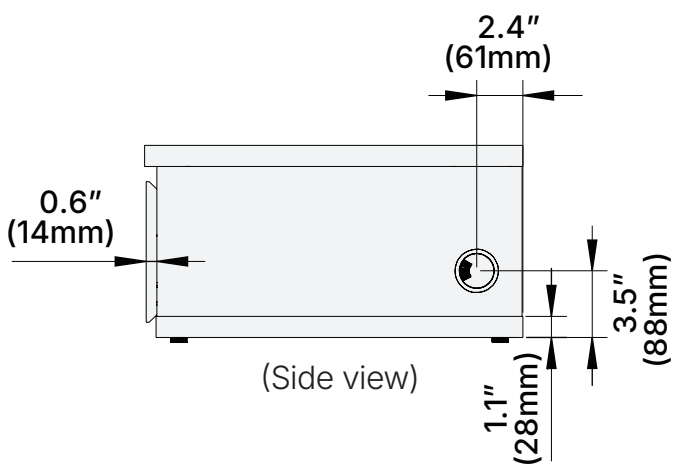
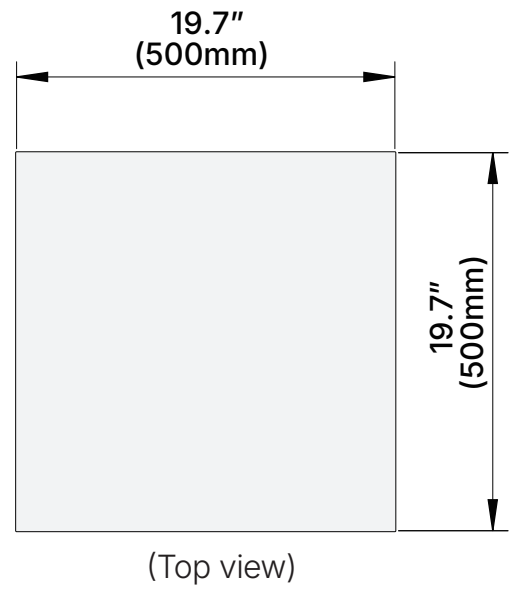
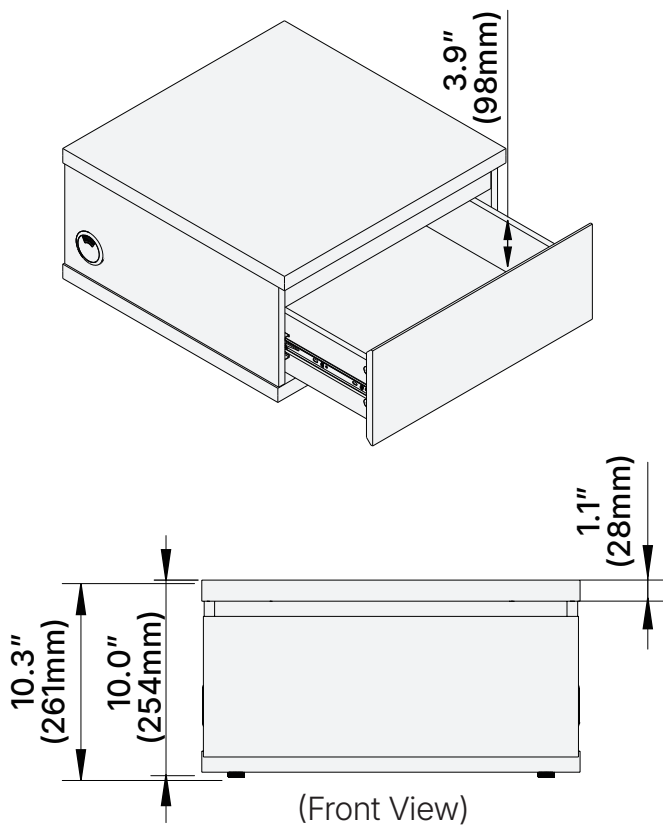

— Made of MDF

Product Feature



Soft-Close Mechanism

Push the drawer gently to close. The soft-close mechanism will engage, allowing the drawer to close slowly and quietly during the final closing motion.

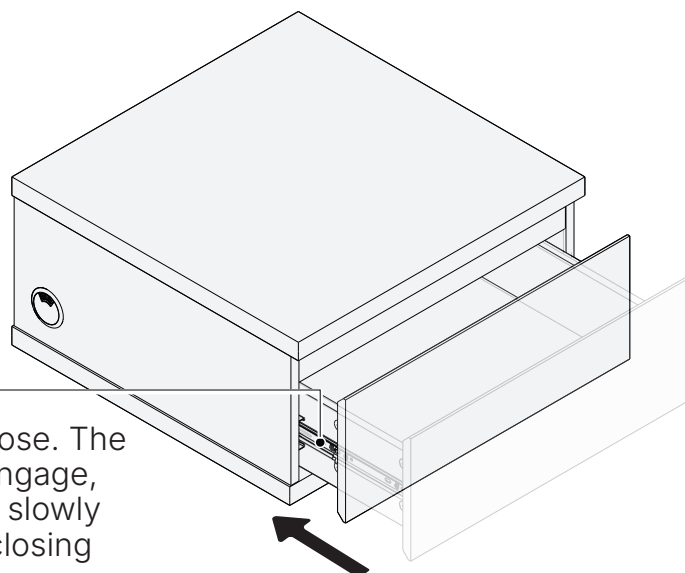

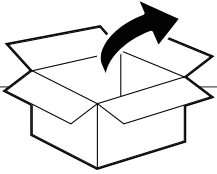
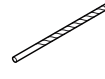
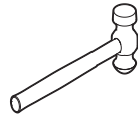
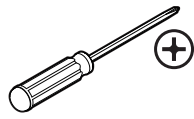
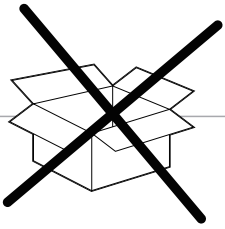

Thumb screw
5/32" x 16mm

(A) x 2

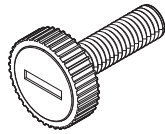

Leveling Foot
M8 x 26mm

(B) x 4

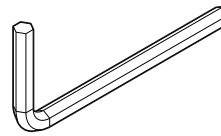

Allen Key

(C) x 1

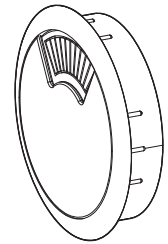

Cable Grommet

(D) x 2

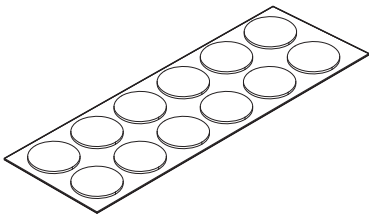

Bumper Pad

(E) x 12

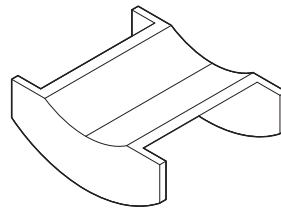

Side Connector

(F) x 1

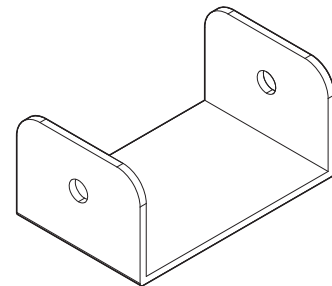

Stacking Connector

(G) x 1



Screw x 1
M4 x 12mm

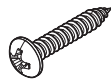

Screw x 1
M4 x 25mm



Washer x 2
Ø4.5 x 1 x Ø14mm

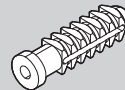

Concrete Anchor
x 1
Ø8 x 30mm

! CAUTION!

This wall anchor is for concrete **ONLY**. DO NOT use them in drywall or wood studs.

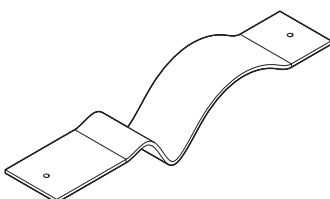

Anti-tipping Strap
x 1

Installation Guide

1 Install Leveling Feet or Bumper Pads

1A If the unit is placed directly on the floor, install the leveling feet.

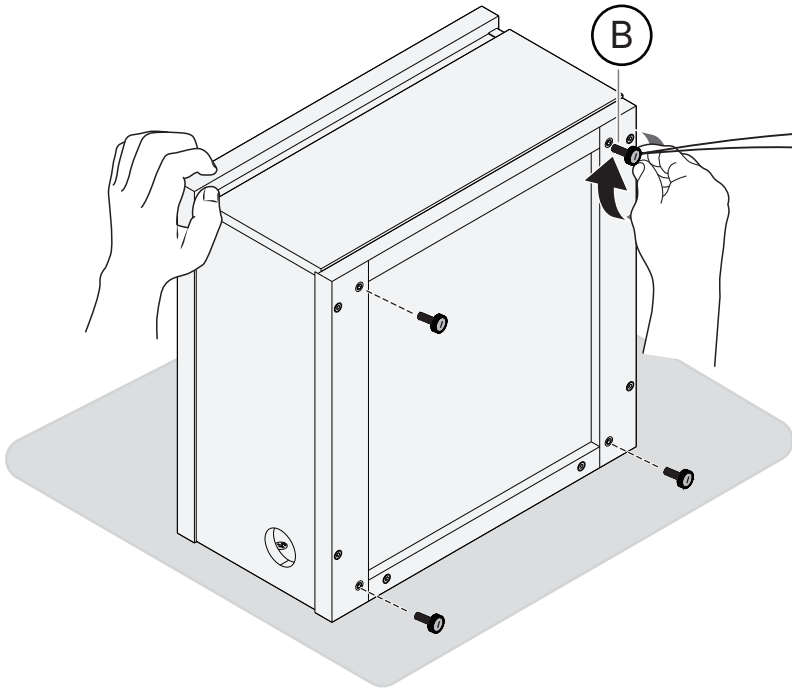
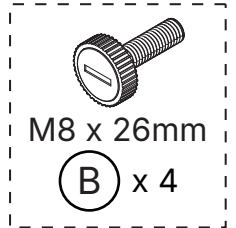

Fully tighten all leveling feet and ensure they are adjusted to the same height.

1B If the unit is placed on top of another cabinet, install the bumper pads.

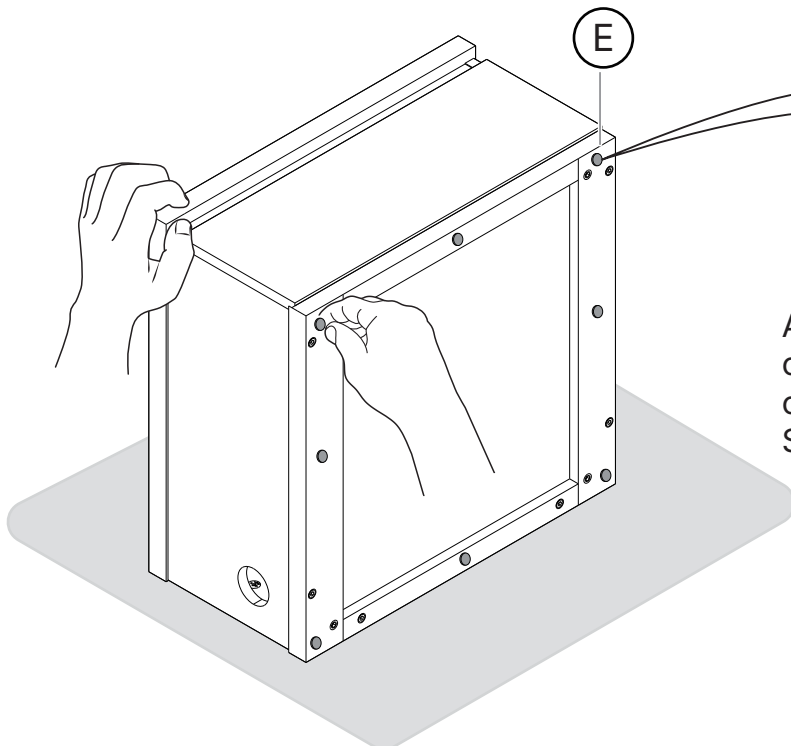
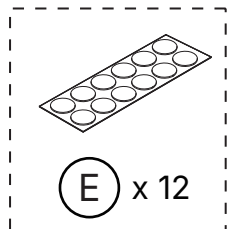

Attach 8 bumper pads to the bottom of the cabinet. Attach 2 bumper pads to the cabinet frame at the drawer contact points. Save the remaining pads for future use.

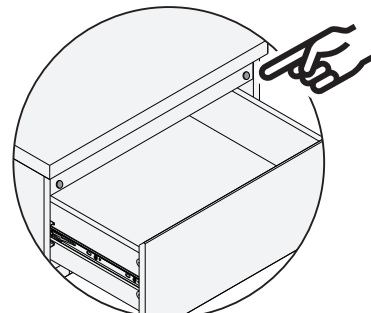

2

Install Side Connector for Side-by-Side Installation (Optional)

Before installing the side connector, press the tab on one side down and the tab on the other side up at the same time to remove the drawer.

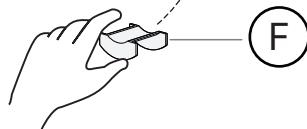
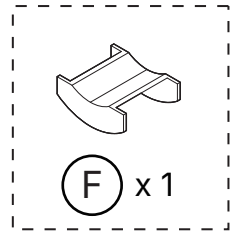
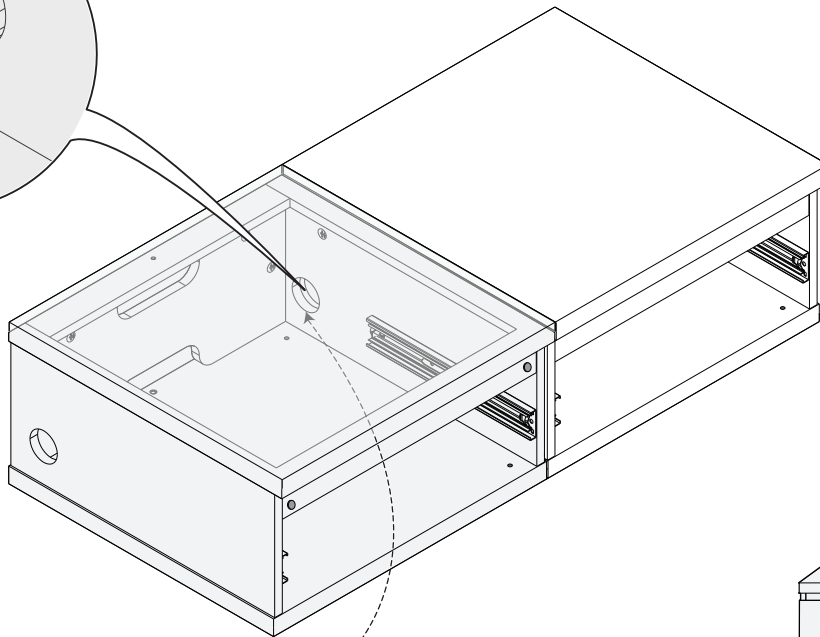
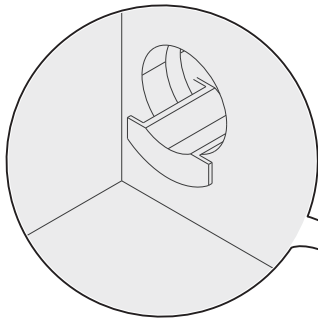
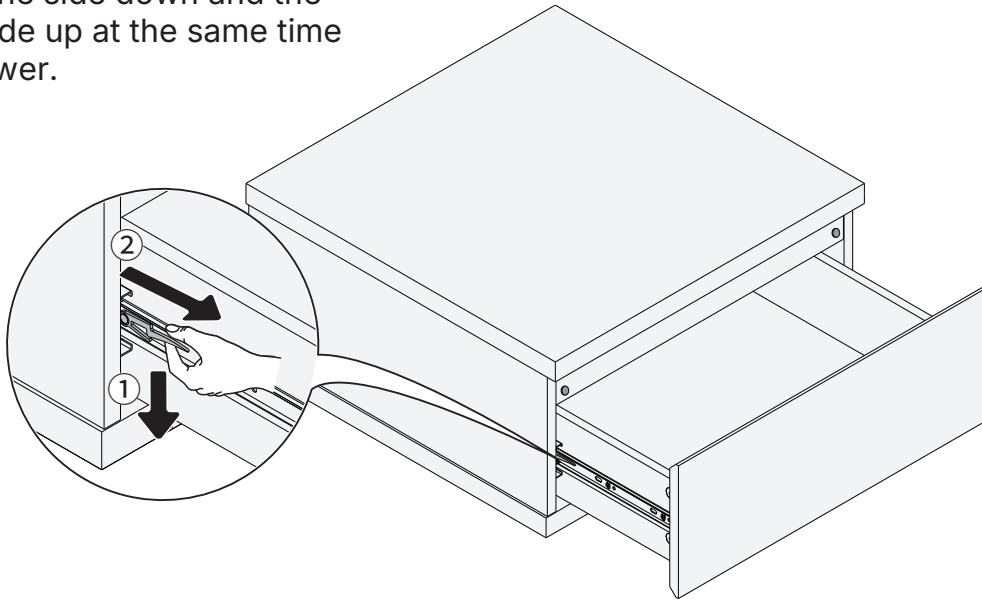



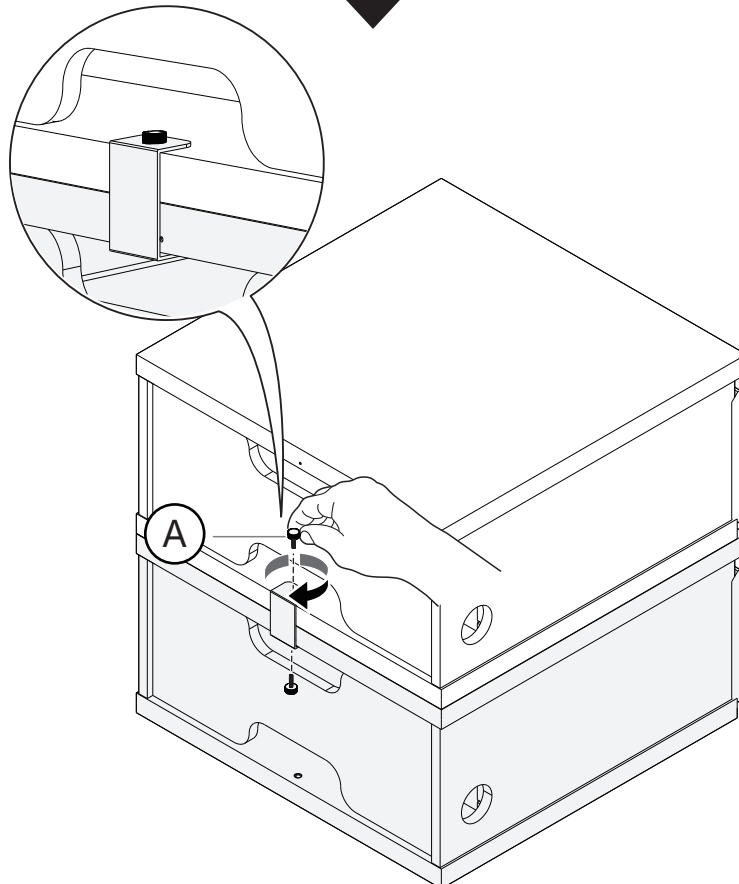
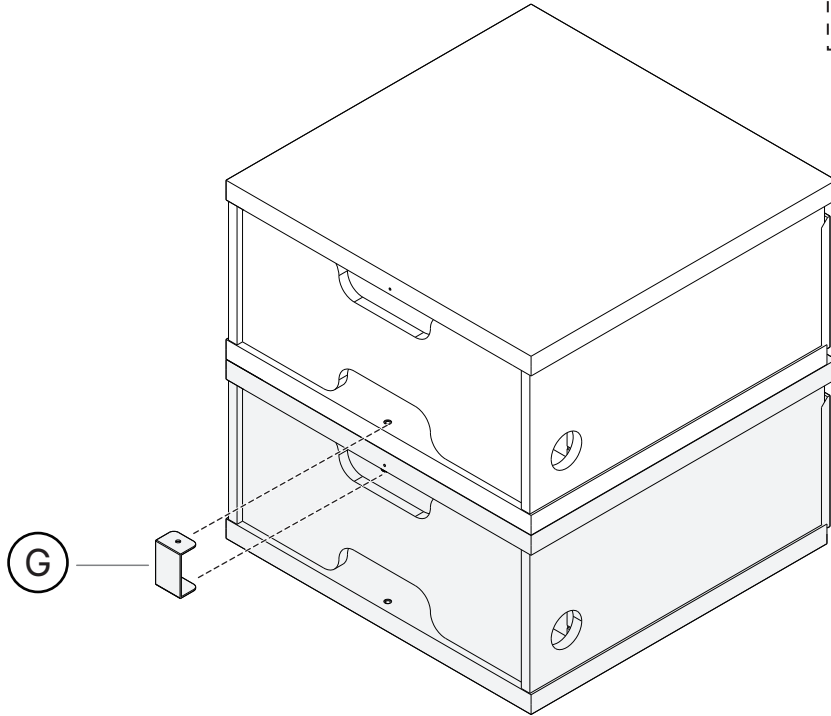
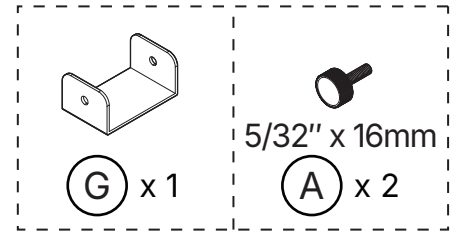

3

Install Stacking Connector for Stacking Installation (Optional)

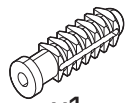

4 Install the Anti-tipping Strap

1. Secure the strap to the back of the unit using short screw and washer.
2. Determine where the unit is to be placed. If you have a wood stud wall, locate a stud using a stud finder and mark the centerline.
3. Drill pilot holes in the wall at the appropriate height.
4. Secure the strap to the wall using long screw and washer. Use wall anchor for solid concrete. Do not use it on wood studs.

-  x1
M4 x 12mm
-  x1
M4 x 25mm
-  x1
Ø8 x 30mm
-  x2
Ø4.5 x 1 x
Ø14mm
-  x1

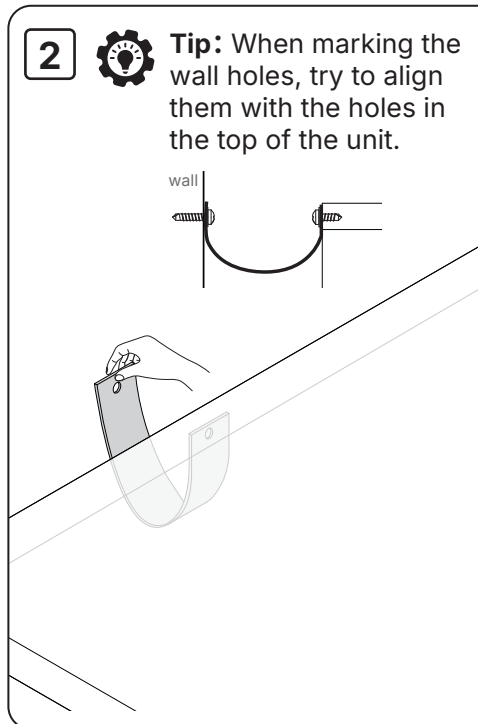
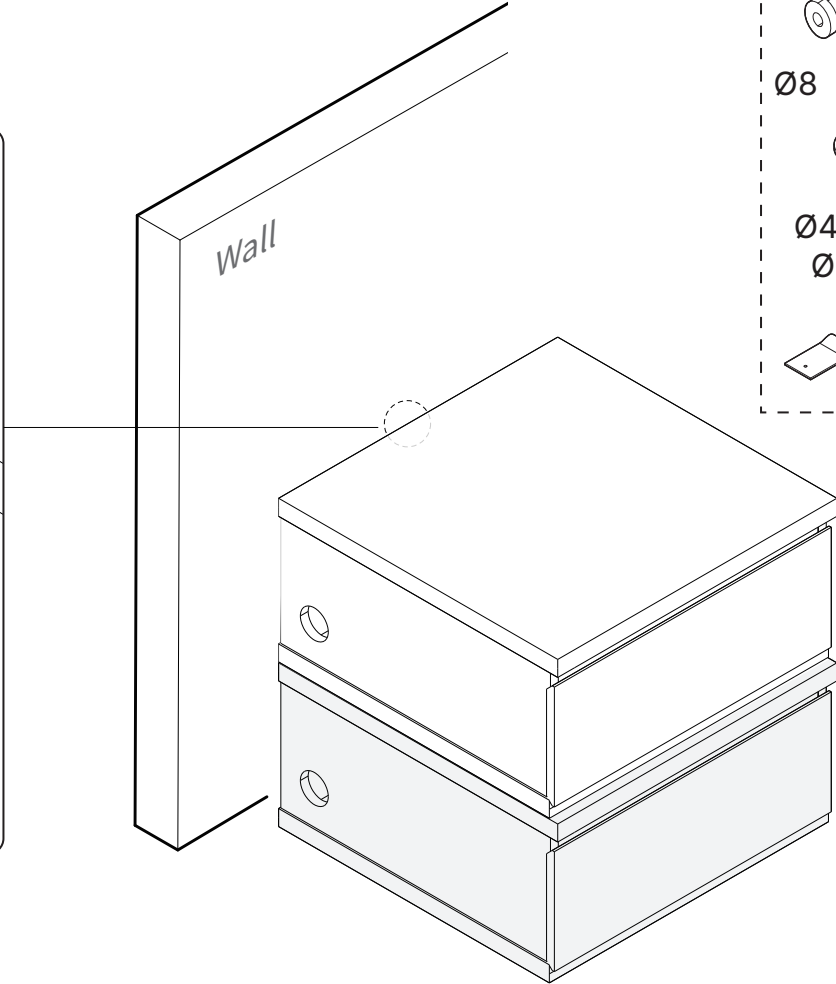
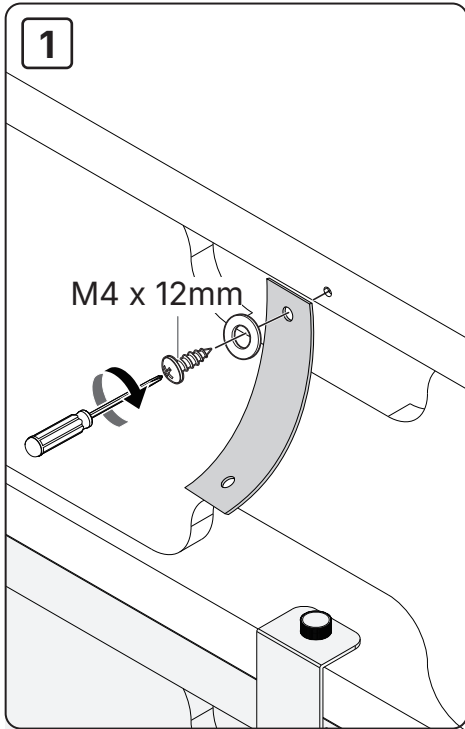

A. Wood Studs

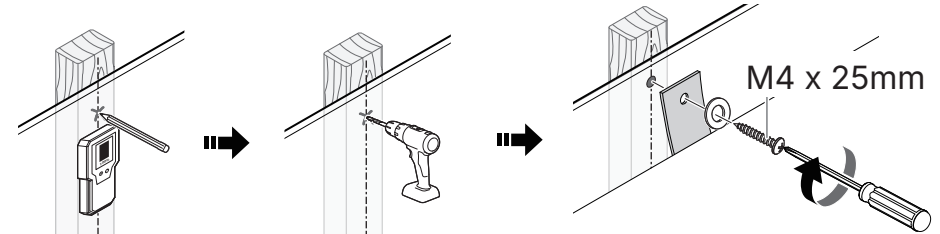
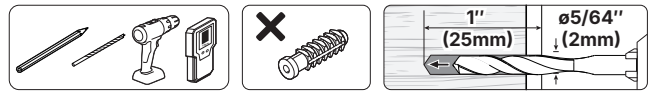

B. Solid Concrete

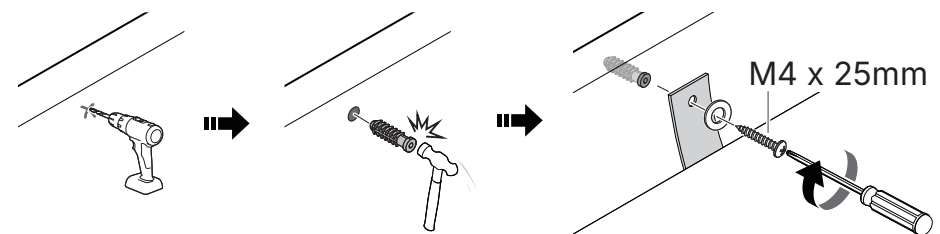
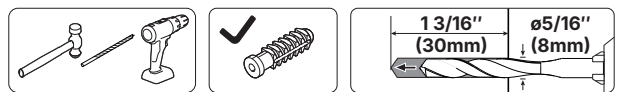

Cable Management

Install Cable Grommets (Optional)

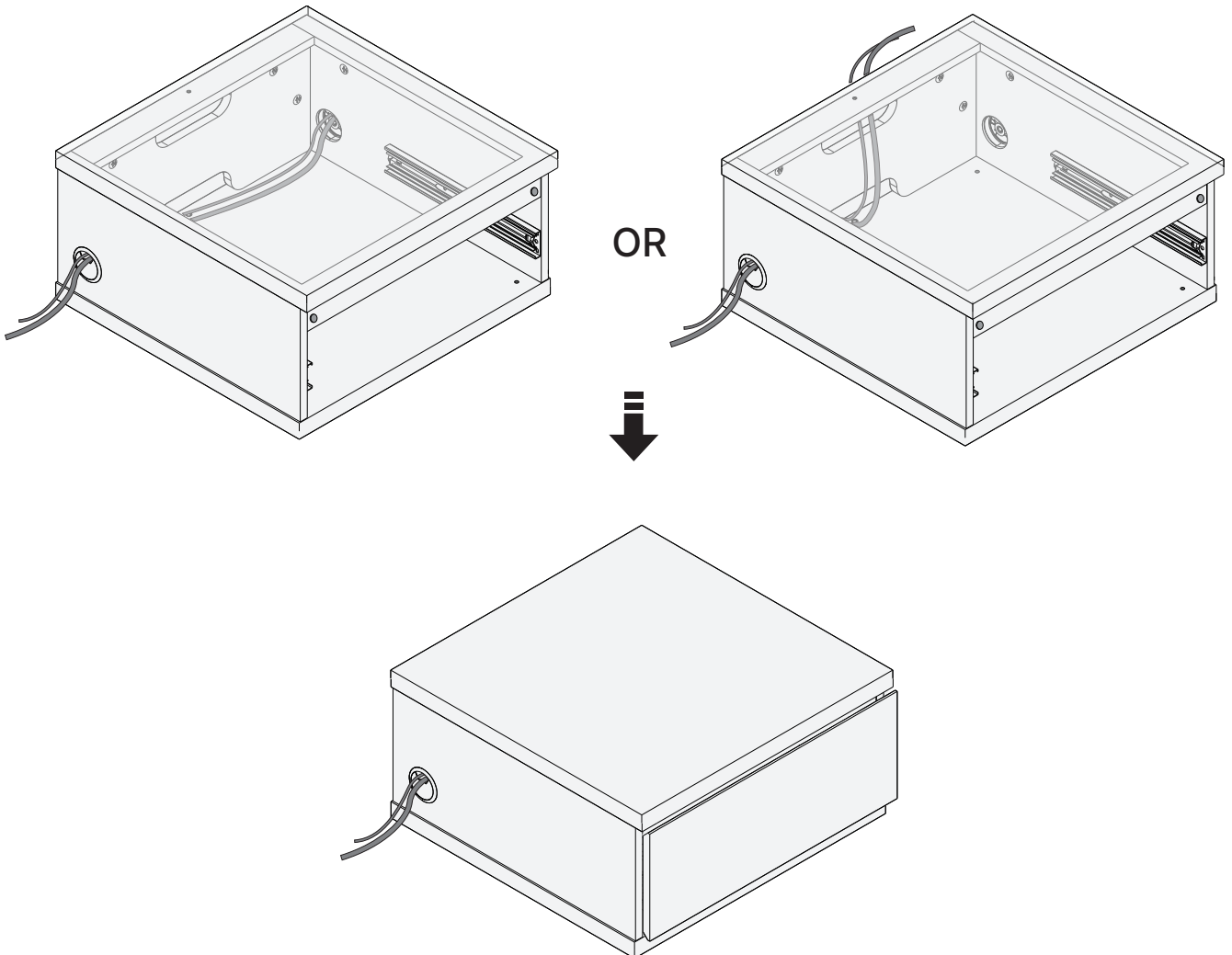
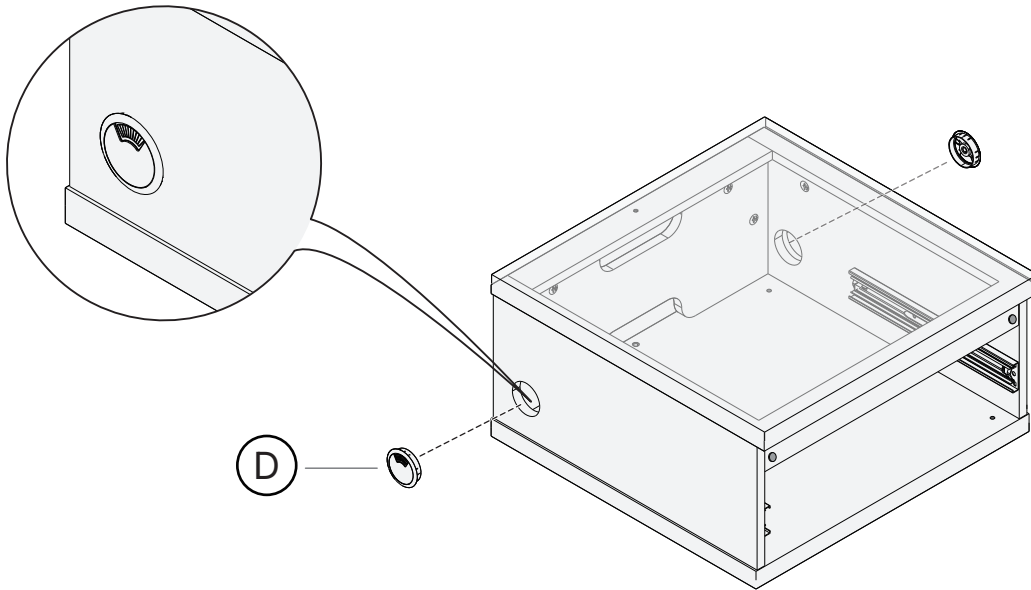

Level Adjustment

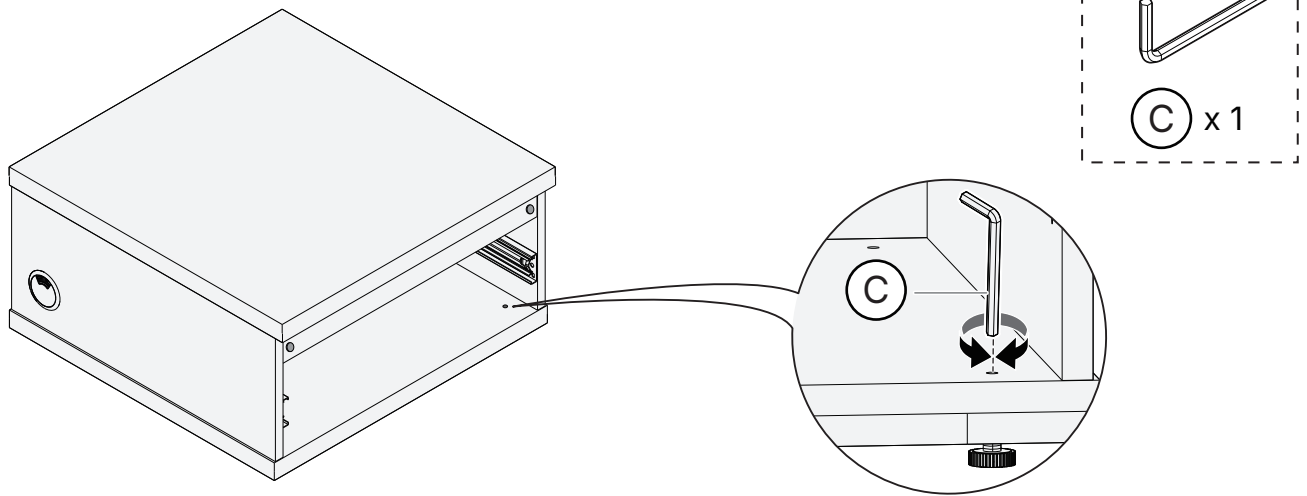

Fine-tune the height of any leveling feet until level.

Possible Configurations

If you have additional modular cabinets from ErgoAV, you can combine them in various configurations as shown below.

- ⚠ WARNING:** Children have died from furniture tipover. To reduce the risk of furniture tipover:
- ALWAYS install tipover restraint provided.
 - NEVER exceed the maximum weight capacity in the instructions.
 - NEVER allow children to stand, climb or hang on drawers, doors, or shelves.
 - NEVER open more than one drawer at a time.
 - Place heaviest items in the lowest drawers, shelves or cabinets.
 - Do Not stack more than two units. When two units are stacked, secure the units tightly using the stacking connector and thumb screws.
 - Never allow stacked cabinets' height to exceed 31 inches from the floor.

Configuration A

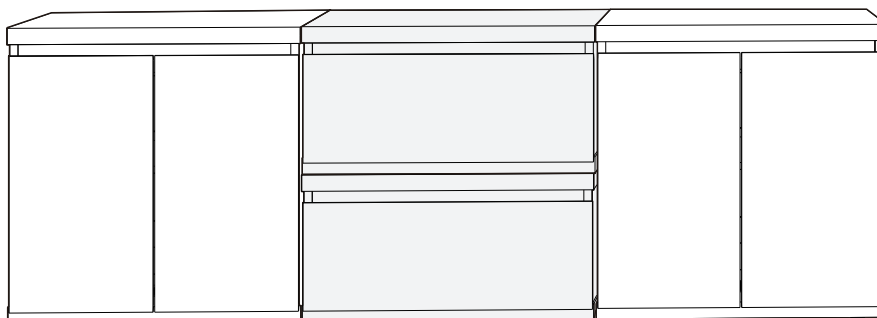

Configuration B

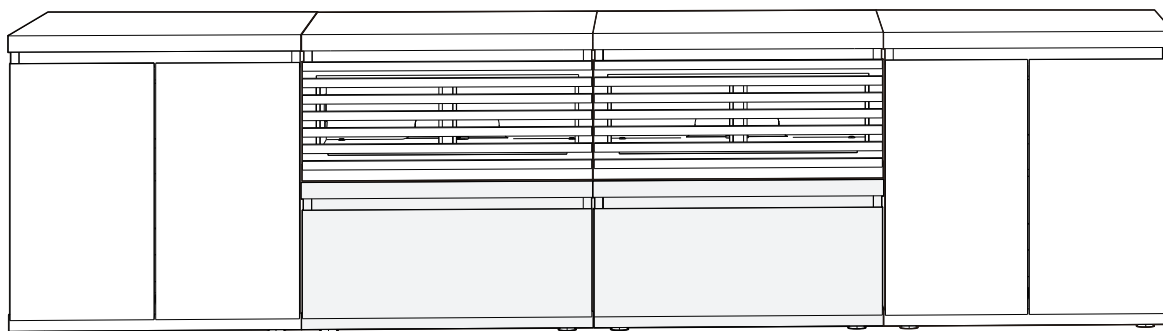

Configuration C

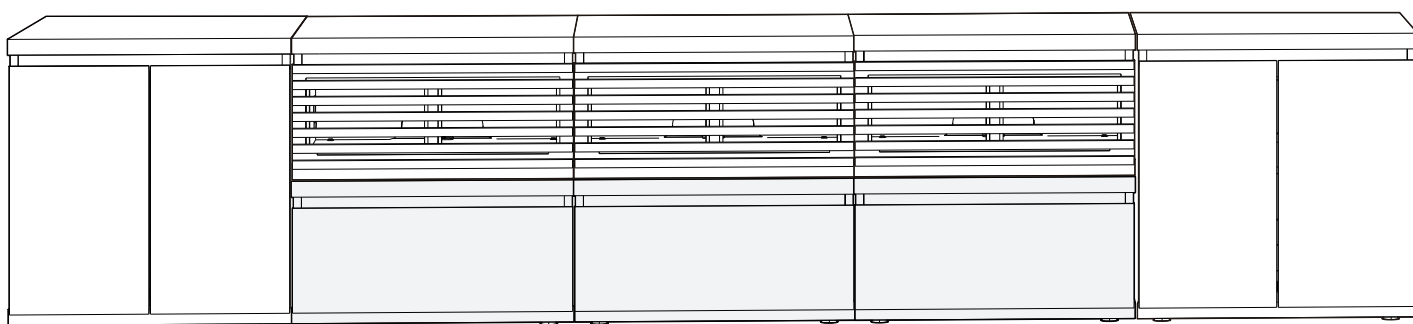

Configuration D



Informations de sécurité importantes

⚠ DANGER : Veuillez lire attentivement toutes les instructions avant de tenter l'installation. Si vous NE COMPRENEZ PAS les instructions ou si vous avez des questions ou des inquiétudes, veuillez appeler le support technique ou envoyer un e-mail au service client.

⚠ ATTENTION : Évitez le risque de blessures personnelles et de dommages matériels !

- NE PAS utiliser ce produit à des fins qui ne sont PAS explicitement spécifiées dans ce manuel. NE PAS dépasser la capacité de poids maximale. Nous ne sommes pas responsables des dommages ou blessures causés par un assemblage incorrect, un montage inapproprié ou une utilisation inadéquate.

- Les informations contenues dans ce manuel NE couvrent PAS toutes les conditions ou variables possibles liées à l'installation de ce produit. Les informations fournies dans ce document sont sujettes à modification sans préavis.

⚠ AVERTISSEMENT: Des enfants ont perdu la vie suite à des renversements de meubles. Afin de réduire les risques de renversement de meubles, veuillez respecter les consignes suivantes :

- TOUJOURS installer le dispositif de fixation anti-renversement fourni.
- NE JAMAIS dépasser la capacité de poids maximale indiquée dans les instructions.
- INTERDIRE formellement aux enfants de se tenir debout, de grimper ou de s'accrocher aux tiroirs, portes ou étagères.
- NE JAMAIS ouvrir plus d'un tiroir à la fois.
- Placez les objets les plus lourds dans les tiroirs, étagères ou armoires les plus bas.
- Ne pas empiler plus de deux unités. Lorsque deux unités sont empilées, fixez-les fermement à l'aide du connecteur d'empilement et des vis à oreilles.
- Ne jamais laisser la hauteur des armoires empilées dépasser 79 cm (31 pouces) du sol.

Spécifications du produit

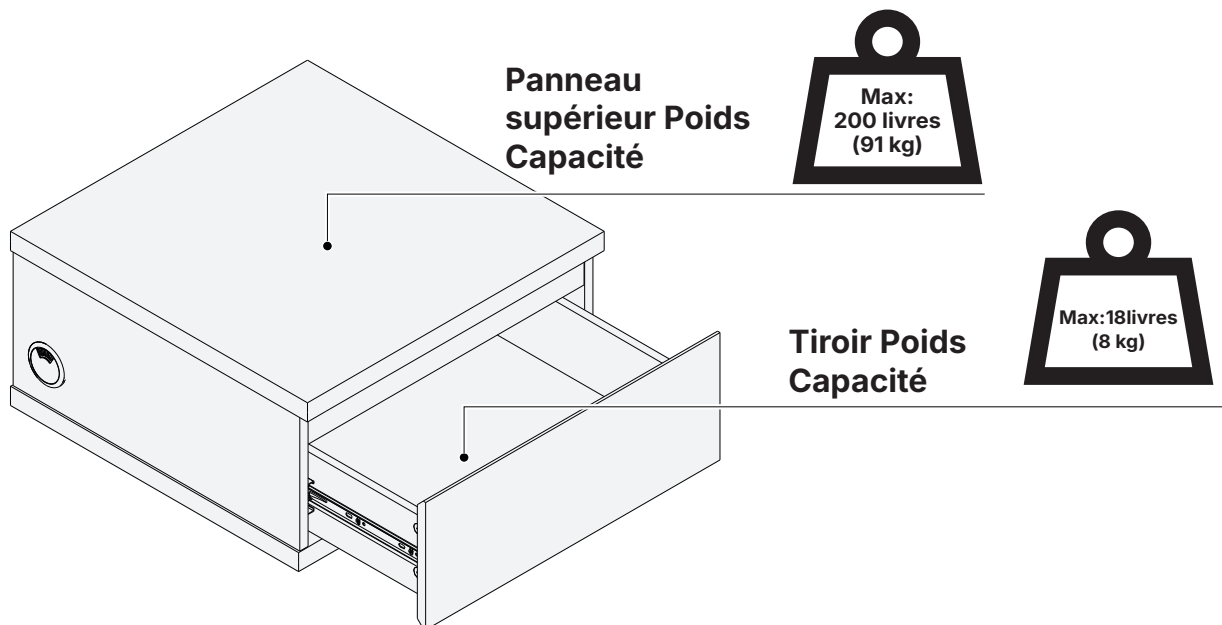

⚠ AVERTISSEMENT

NE PAS dépasser le poids maximum indiqué. Cette armoire est destinée à être utilisée uniquement dans les limites de poids indiquées. L'utilisation avec des produits plus lourds que la limite de poids maximale peut entraîner une défaillance de l'armoire, causant des dommages potentiels et/ou des blessures. NE PAS dépasser les limites de poids spécifiées.

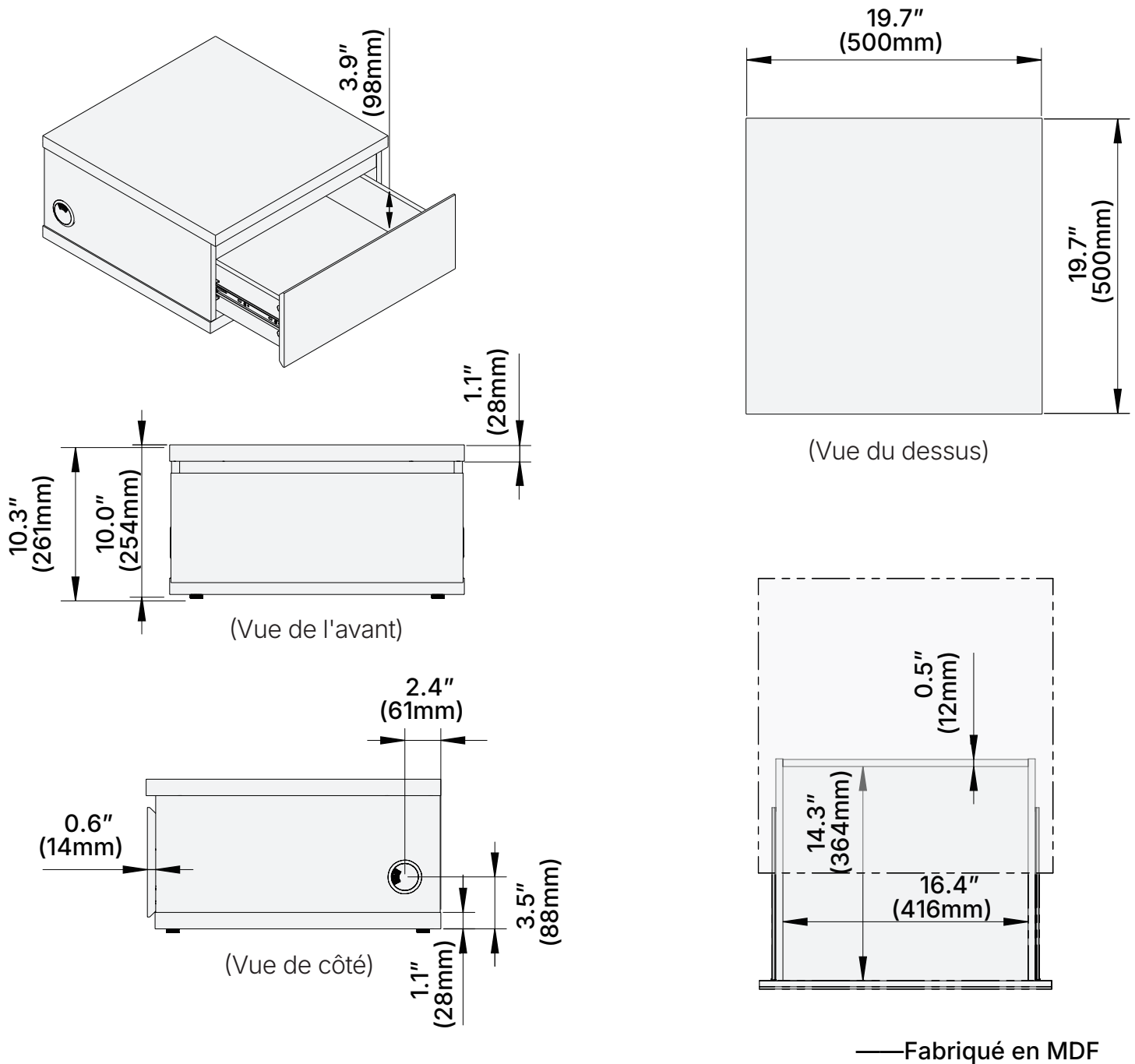

Caractéristique du produit



Mécanisme Fermé-doux

Pousser le tiroir doucement afin qu'il soit fermé. Le mécanisme à fermeture douce va s'engager, permettant au tiroir d'être fermé lentement et silencieusement pendant le mouvement final de fermeture.

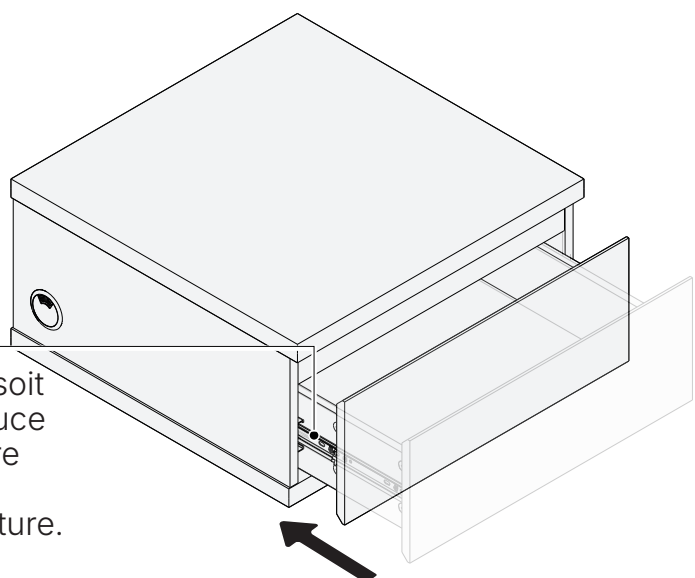

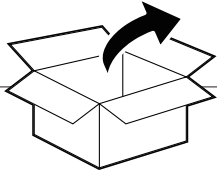
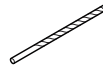
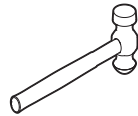
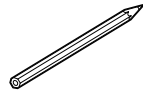
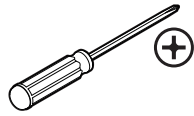
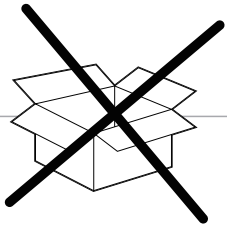

Vis à oreilles
5/32" x 16mm

(A) x 2

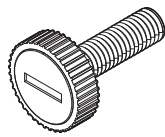

Pied de mise à niveau
M8 x 26mm

(B) x 4

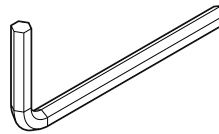

Clé allen

(C) x 1

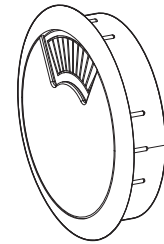

Passe-câble

(D) x 2

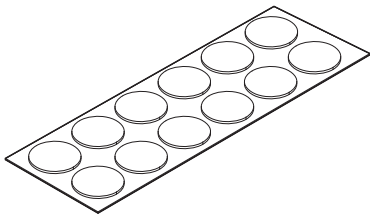

Pad de Pare-chocs

(E) x 12

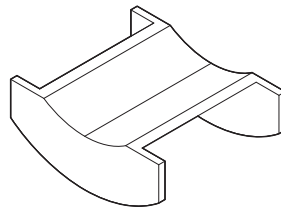

Connecteur latéral

(F) x 1

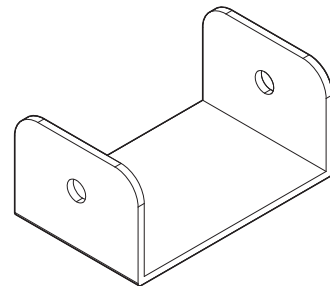

Connecteur d'empilage

(G) x 1



Vis x 1
M4 x 12mm

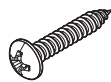

Vis x 1
M4 x 25mm



Rondelle x 2
Ø4,5 x 1 x Ø14 mm

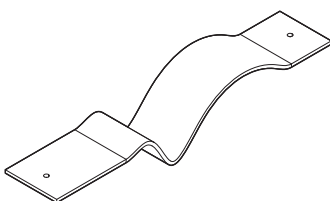

Sangle anti-basculement x 1

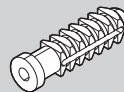

Ancre pour
béton x 1
Ø8 x 30mm

! ATTENTION!

Cet ancrage au mur est uniquement pour le béton. Ne procédez pas à l'utilisation de cet ancrage au mur dans la cloison sèche ou les montants en bois.

1 Installation de Pieds de nivellement ou de Pads de Pare-chocs

1A Si l'unité est en place directement sur le plancher, procédez à l'installation des pieds de nivellement.

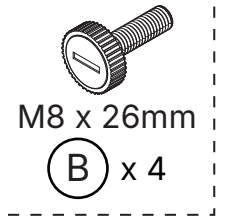
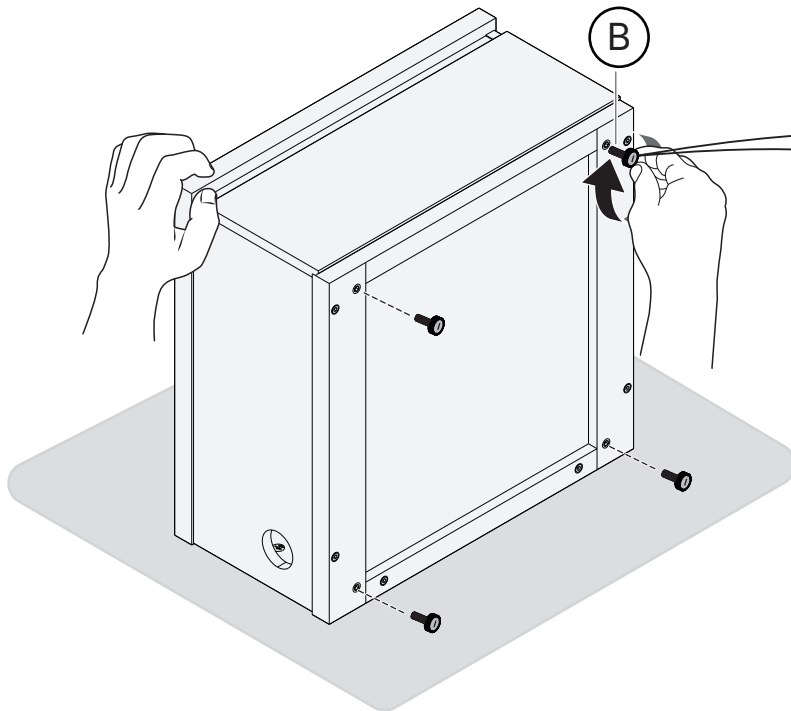

Serrer complètement tous les pieds de nivellement et assurer leur ajustement à la même hauteur.

1B Si la place de l'unité est sur le dessus d'une autre armoire, procédez à l'installation des pads de pare-chocs.

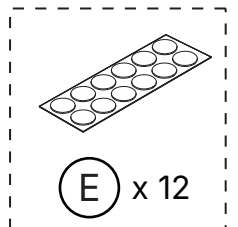
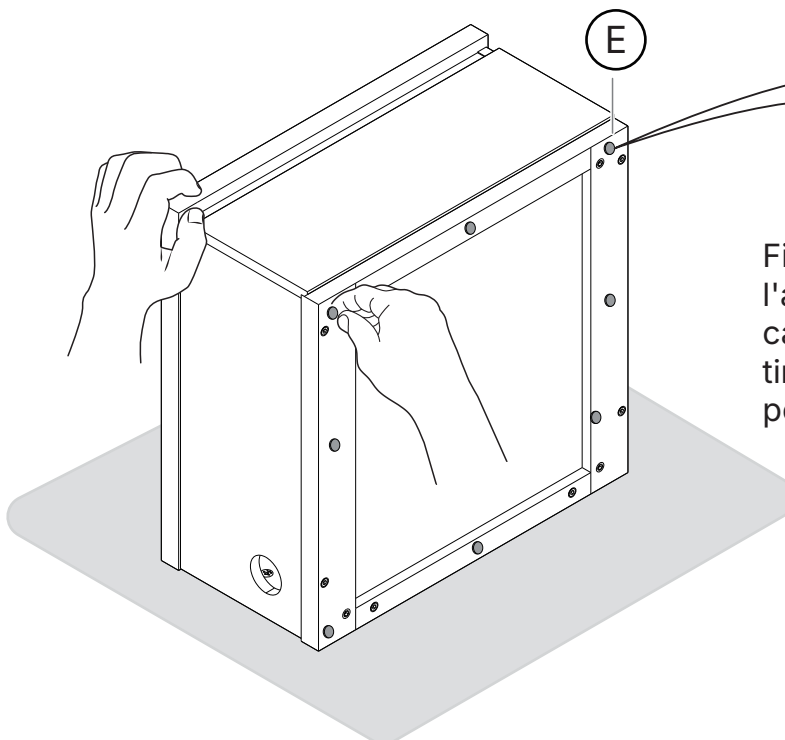

Fixation de 8 pare-chocs pads au fond de l'armoire. Fixation de 2 pare-chocs pads au cadre de l'armoire aux points de contact du tiroir. Conservez la partie restante des pads pour une utilisation future.

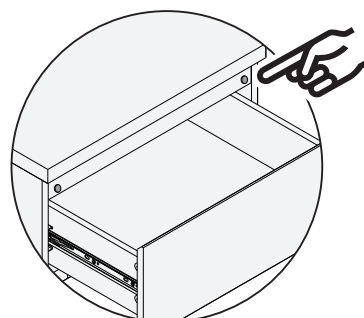

2

Installation du Connecteur latéral pour Installation côte à côte (Optionnel)

Avant d'installer le connecteur latéral, appuyez simultanément sur la languette d'un côté vers le bas et sur la languette de l'autre côté vers le haut pour retirer le tiroir.

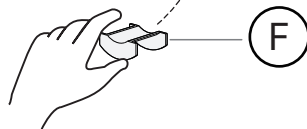
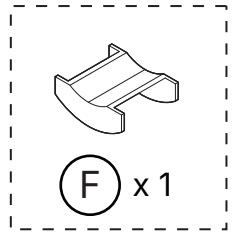
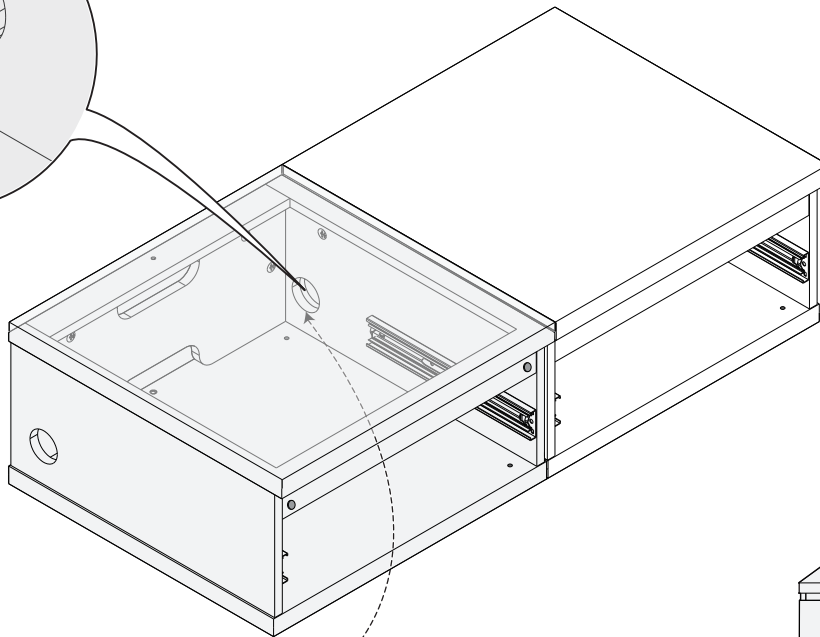
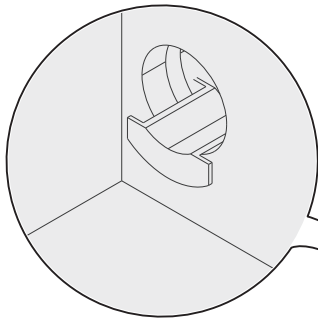
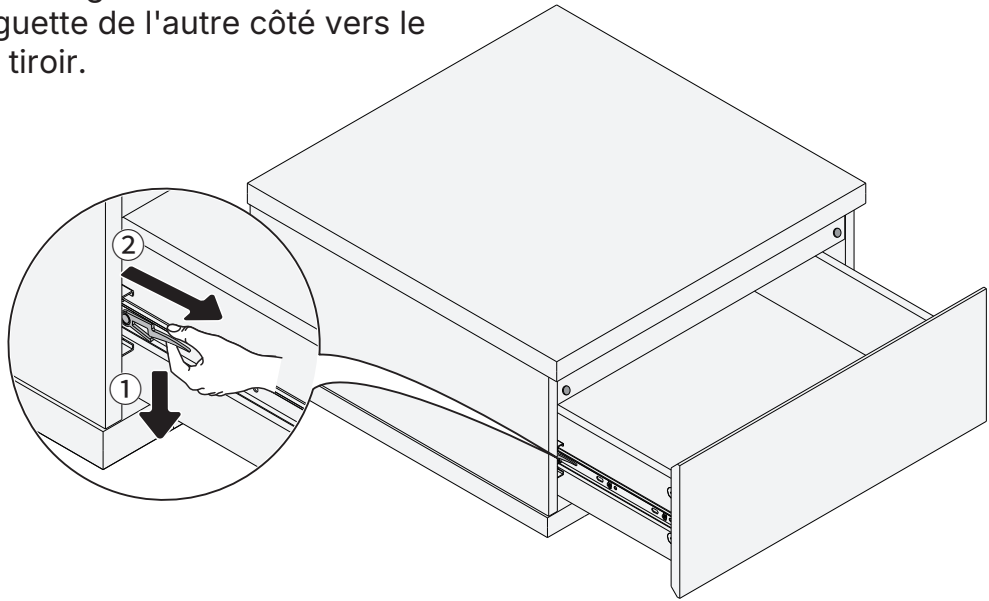

3

Installation du Connecteur d'empilage pour l'Installation d'empilage (Optionnel)

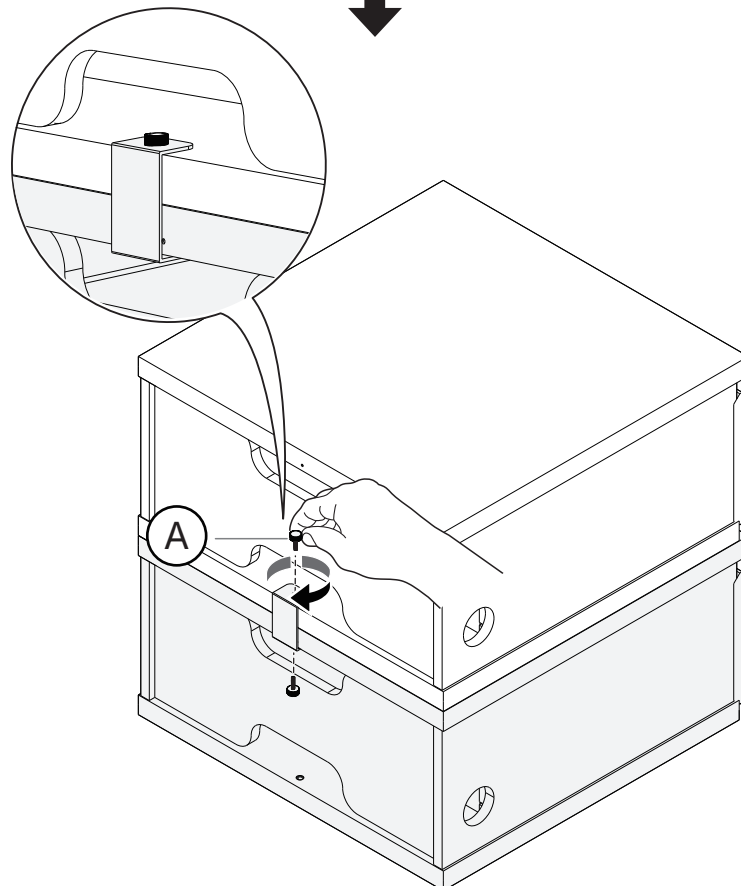
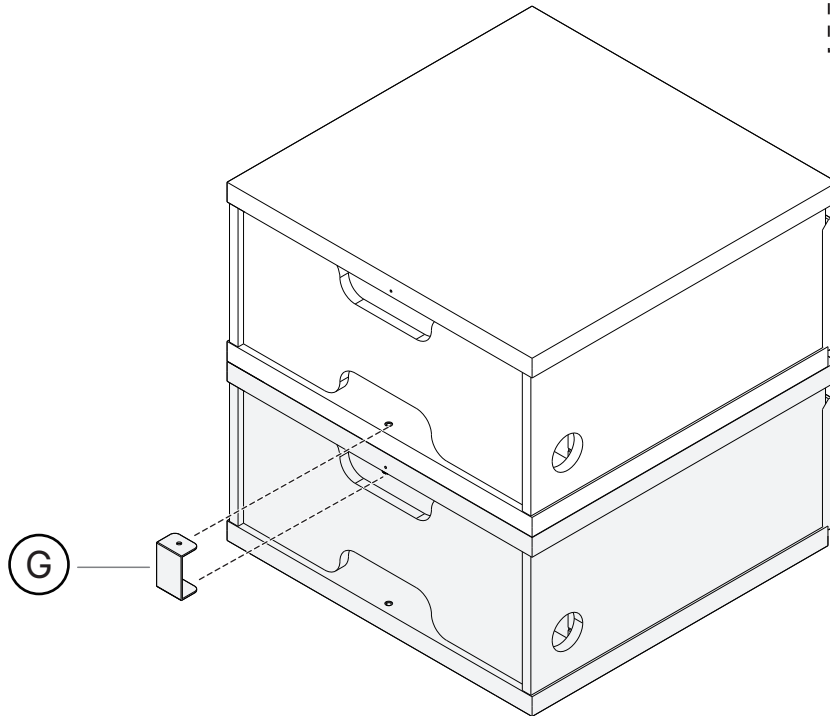
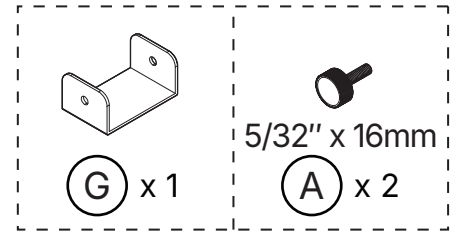

4

Installation de la Sangle anti-basculement

1. Fixez la sangle à l'arrière de l'unité à l'aide d'une vis courte et d'une rondelle.
2. Déterminer où l'unité doit être placée. Si vous avez un mur à montants en bois, localiser un montant à l'aide d'un détecteur de montants et apposer une marque sur la ligne centrale.
3. Perceuse: trous pilotes dans le mur à la hauteur appropriée.
4. Sécuriser la sangle au mur en utilisant une longue vis et une rondelle. Utilisation de l'ancrage au mur pour le béton solide. Ne faites pas l'utilisation de l'ancrage au mur sur des montants en bois.

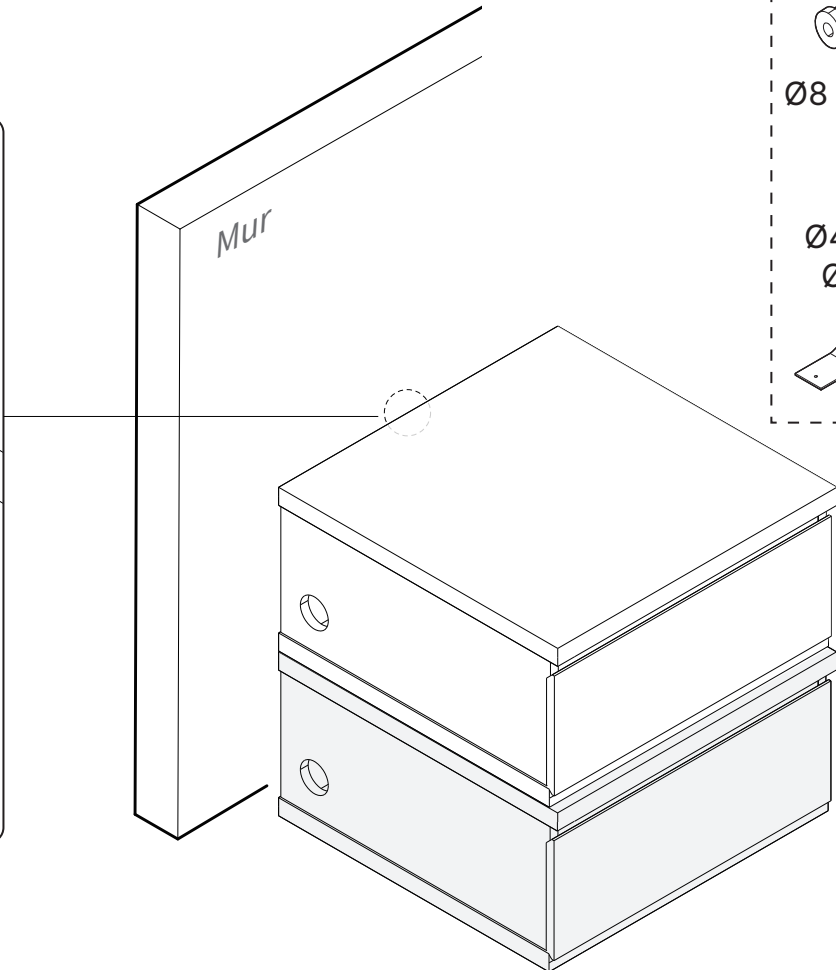
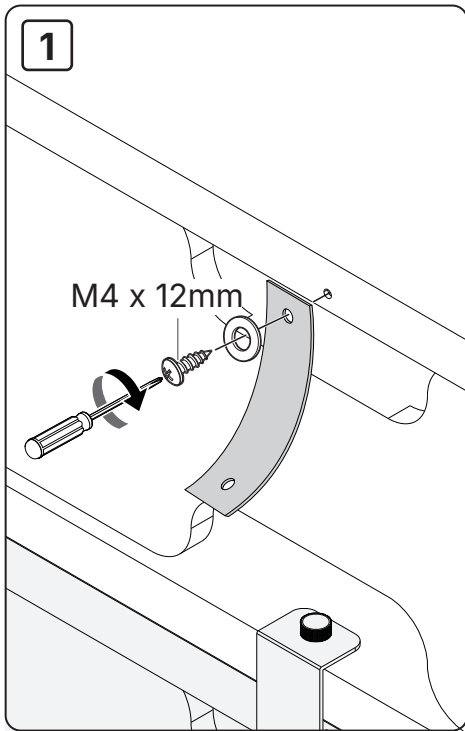
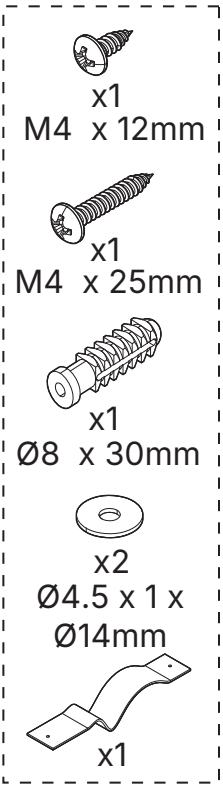

2 **Conseil:** Lors de la marque des trous du mur, essayer de procéder à un alignement des trous du mur sur les trous dans le dessus de l'unité.

A. Montants en bois

M4 x 25mm

B. Béton solide

M4 x 25mm

Installation de passe-câbles (Optionnel)

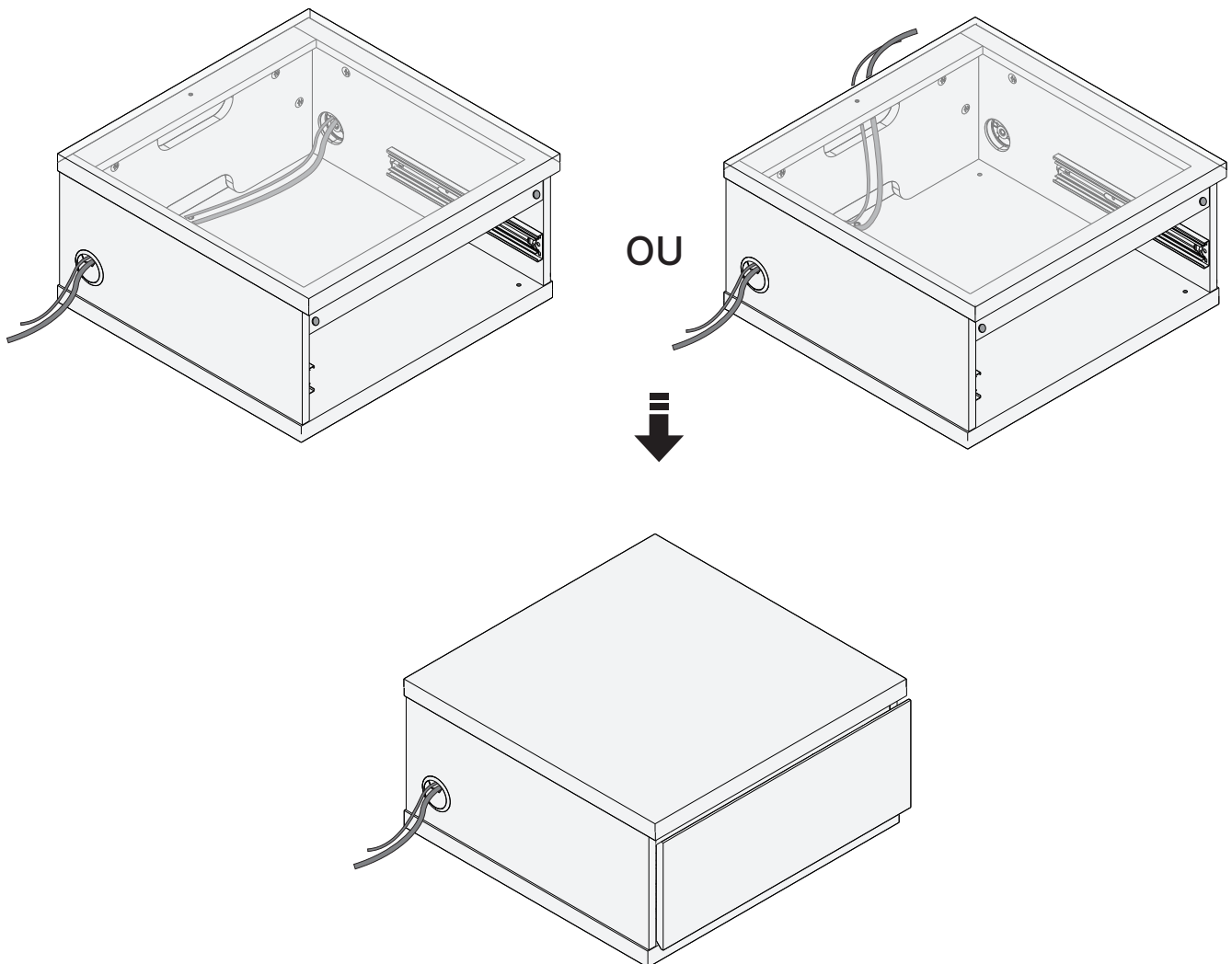
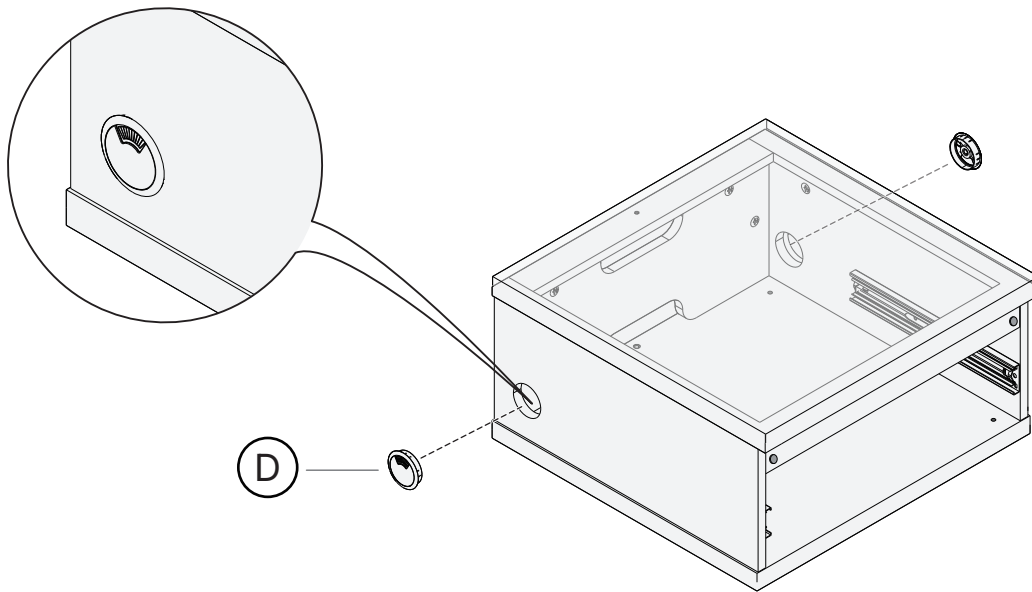

Réglage du niveau

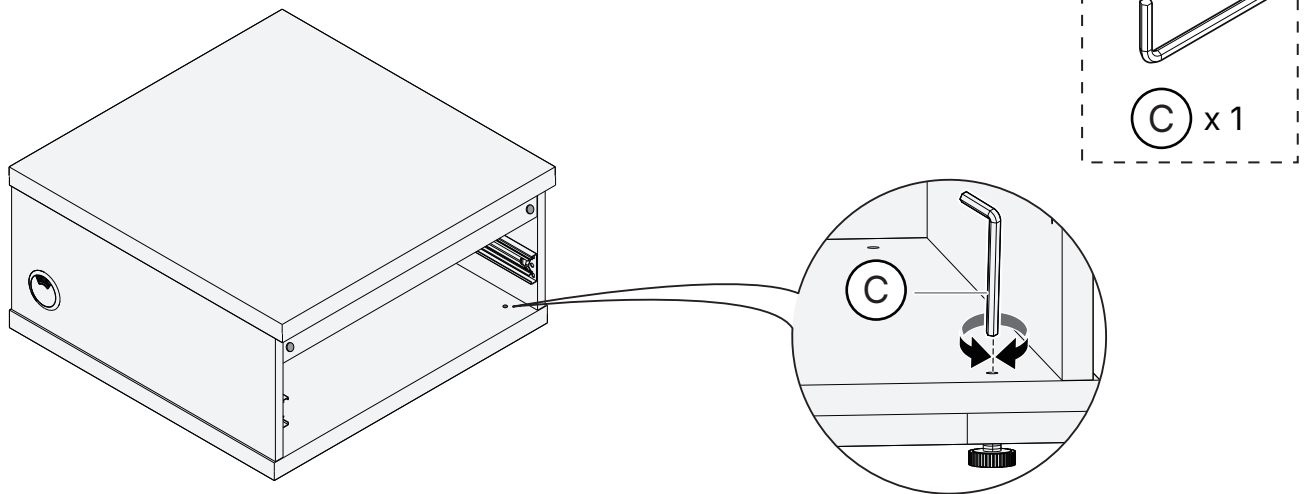

Réglez avec précision la hauteur des pieds réglables jusqu'à ce que l'appareil soit à niveau.

Configurations possibles

Si vous avez des armoires modulaires supplémentaires d'ErgoAV, vous pouvez les combiner dans différents types de configuration comme indiqué ci-dessous.

⚠ AVERTISSEMENT: Des enfants ont perdu la vie suite à des renversements de meubles. Afin de réduire les risques de renversement de meubles, veuillez respecter les consignes suivantes :

- TOUJOURS installer le dispositif de fixation anti-renversement fourni.
- NE JAMAIS dépasser la capacité de poids maximale indiquée dans les instructions.
- INTERDIRE formellement aux enfants de se tenir debout, de grimper ou de s'accrocher aux tiroirs, portes ou étagères.
- NE JAMAIS ouvrir plus d'un tiroir à la fois.
- Placez les objets les plus lourds dans les tiroirs, étagères ou armoires les plus bas.
- Ne pas empiler plus de deux unités. Lorsque deux unités sont empilées, fixez-les fermement à l'aide du connecteur d'empilement et des vis à oreilles.
- Ne jamais laisser la hauteur des armoires empilées dépasser 79 cm (31 pouces) du sol.

Configuration A

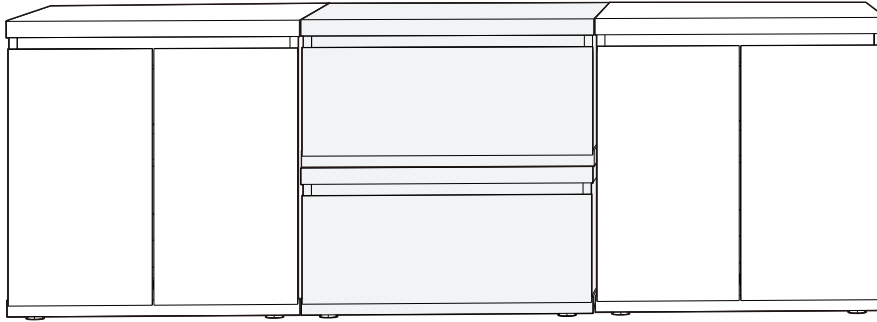

Configuration B

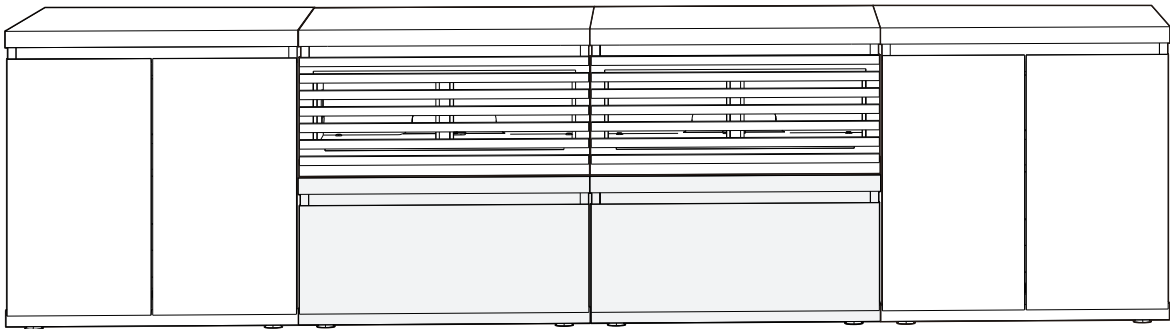

Configuration C

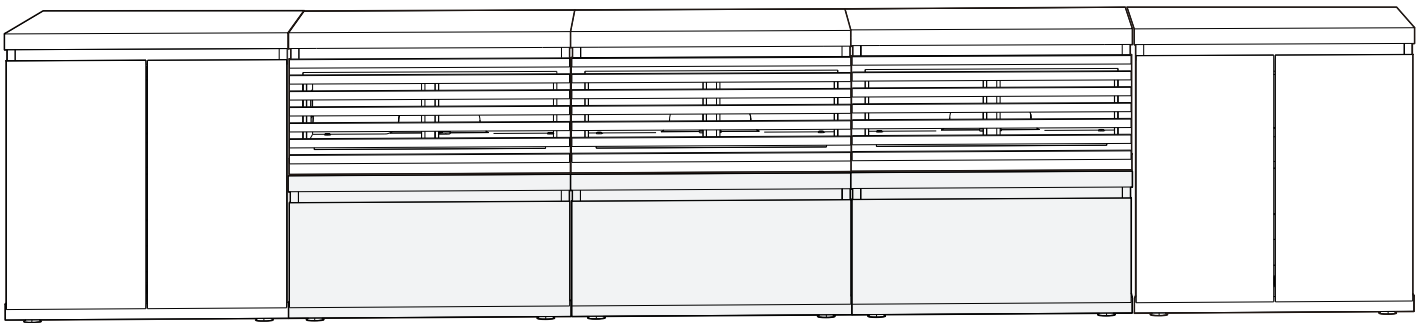

Configuration D

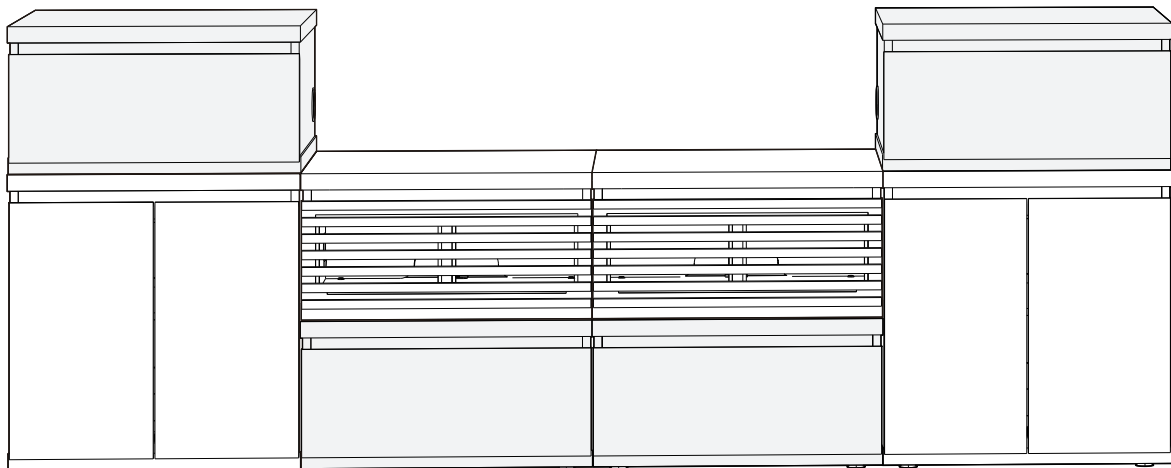

Información de seguridad importante

⚠ PELIGRO: Por favor, lea detenidamente todas las instrucciones antes de intentar la instalación. Si NO entiende las instrucciones o tiene alguna pregunta o inquietud, llame al soporte técnico o envíe un correo electrónico al servicio al cliente.

⚠ PRECAUCIÓN: ¡Evite el riesgo de lesiones personales y daños a la propiedad!

- NO use este producto para ningún propósito que NO esté explícitamente especificado en este manual. NO exceda la capacidad de peso máxima. No nos hacemos responsables de los daños o lesiones causados por un montaje incorrecto, montaje inadecuado o uso inapropiado.
- La información contenida en este manual NO cubre todas las posibles condiciones o variables relacionadas con la instalación de este producto. La información proporcionada en este documento está sujeta a cambios sin previo aviso.

⚠ ADVERTENCIA: Niños han muerto por el vuelco de muebles. Para reducir el riesgo de vuelco de muebles:

- SIEMPRE realice la instalación del anclaje antivuelco que se debe proporcionar.
- NUNCA exceda la capacidad de peso máxima indicada en las instrucciones.
- NUNCA permitir a los niños pararse, trepar o colgar en los cajones, la puerta o los estantes.
- NUNCA abrir más de un cajón en un momento.
- Colocar los artículos más pesados en los cajones, estantes o armarios más bajos.
- No apile más de dos unidades. Cuando se apilen dos unidades, mantenga las unidades firmemente seguras usando el conector de apilado y tornillos de mariposa.
- Nunca permitir que la altura de los gabinetes apilados llegue a superar 31 pulgadas desde el piso.

Especificaciones del producto

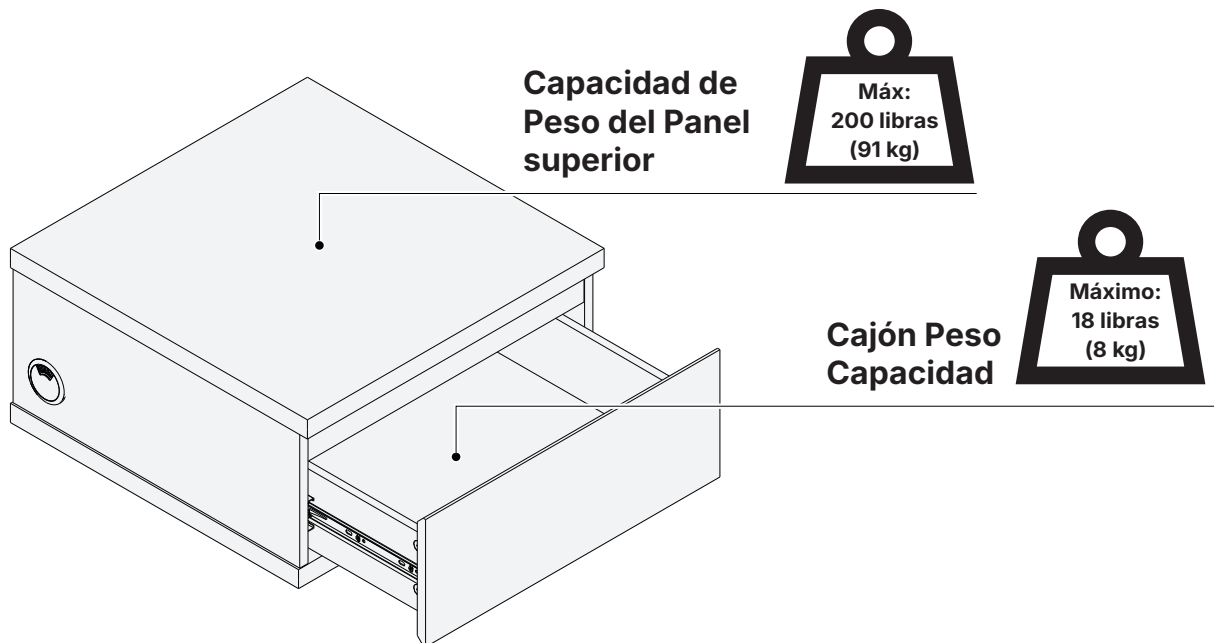

⚠ ADVERTENCIA

NO exceda el peso máximo indicado. Este gabinete está diseñado para ser utilizado solo dentro de los rangos de peso especificados. El uso con productos más pesados que el límite de peso máximo puede provocar el fallo del gabinete, causando posibles daños y/o lesiones. NO exceda los límites de peso especificados.

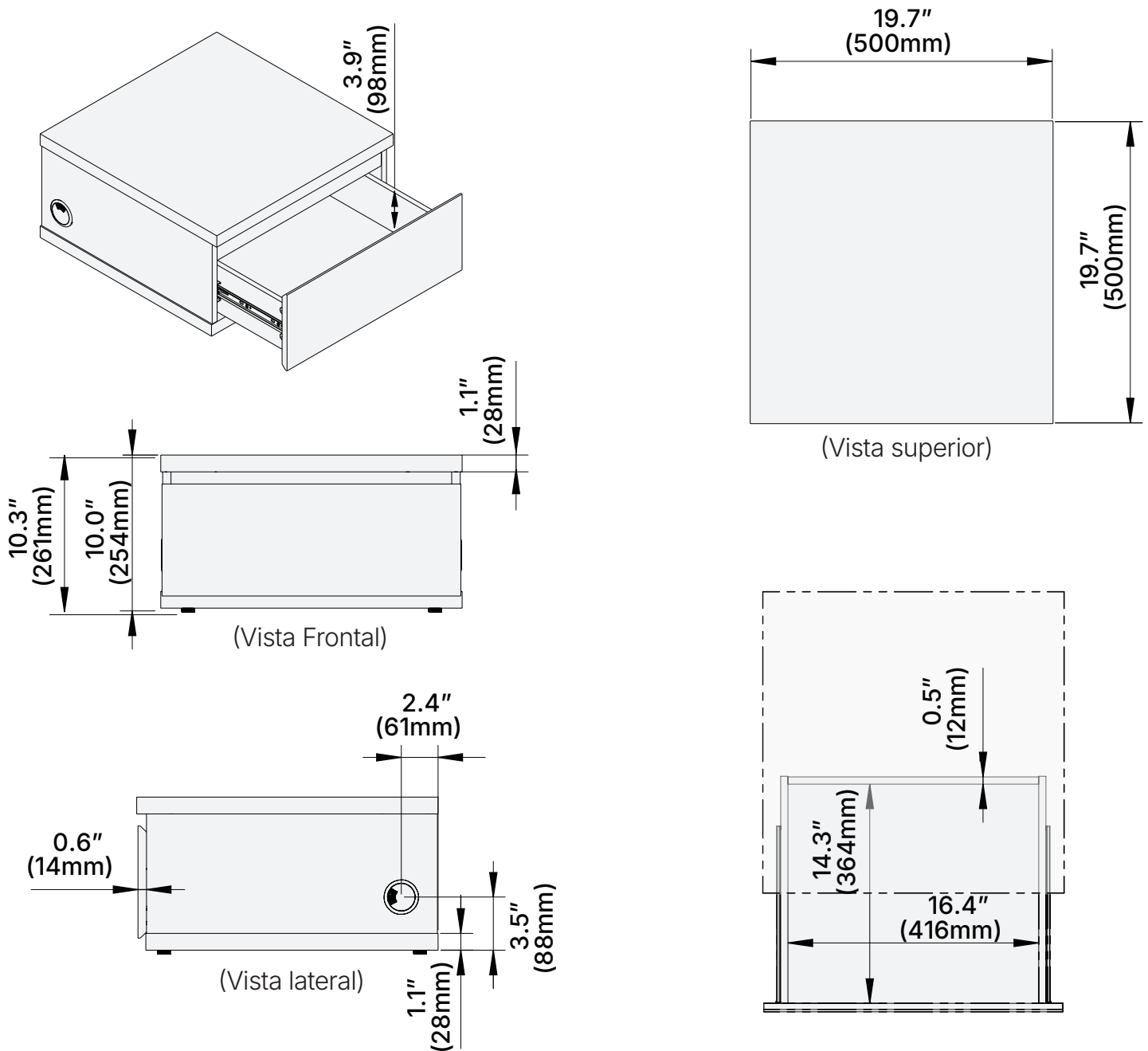

—Hecho de MDF

Característica del producto



Mecanismo de Cerrar Suavemente

Empujar el cajón suavemente para cerrar. El mecanismo de cerrar suavemente se comprometerá, permitiendo cerrar el cajón lentamente y silenciosamente durante el movimiento final de cerrar.

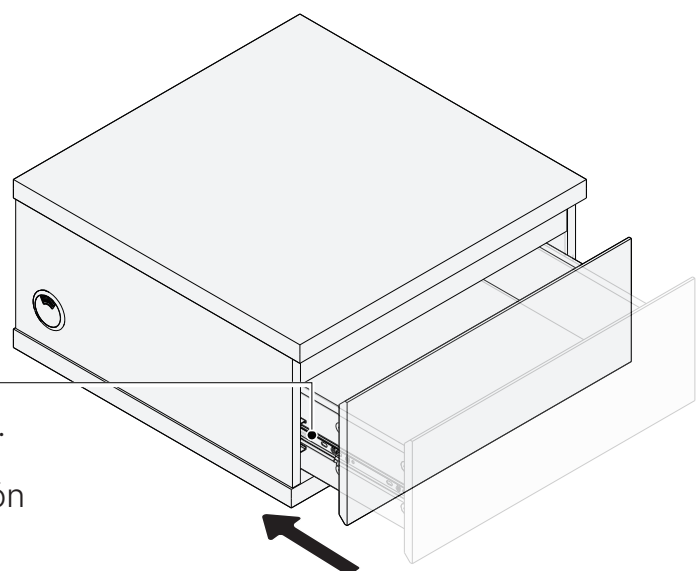

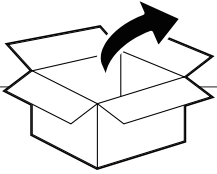
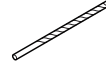
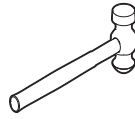
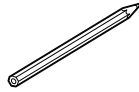
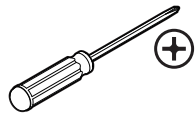
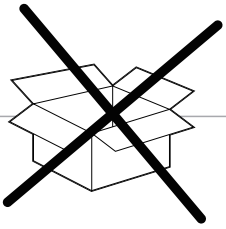

tornillo moleteado
5/32" x 16mm

(A) x 2

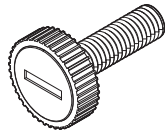

Pata de Nivel
M8 x 26mm

(B) x 4

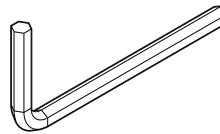

Llave allen

(C) x 1

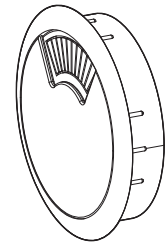

Pasacables

(D) x 2

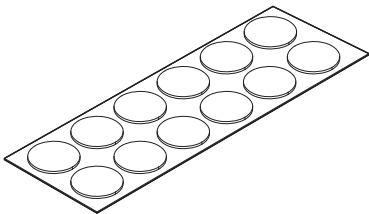

Almohadilla de parachoques

(E) x 12

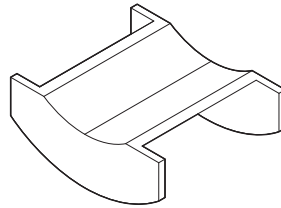

Conector lateral

(F) x 1

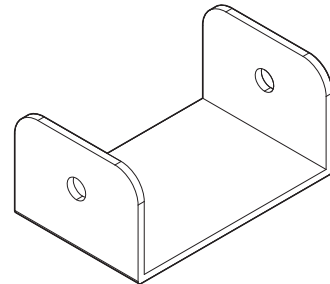

Conector apilable

(G) x 1



Tornillo x 1
M4 x 12mm

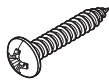

Tornillo x 1
M4 x 25mm



Arandela x 2
Ø4,5 x 1 x Ø14mm

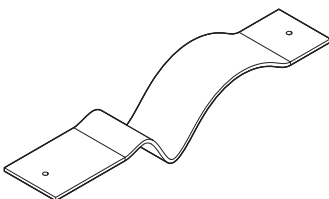

Correa anti-propinas x 1

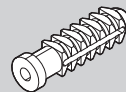

Anclaje para
concreto x 1
Ø8 x 30 mm

¡PRECAUCIÓN!

Este anclaje de pared
es para concreto
ÚNICAMENTE. NO
haga uso de él en
panel de yeso ni en
montantes de
madera.

1 Instalación de patas niveladoras o almohadillas de parachoques

1A Si la unidad se va a colocar directamente sobre el piso, realice la instalación de las patas niveladoras.

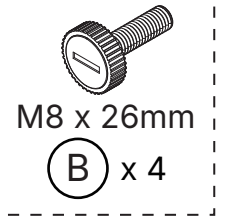
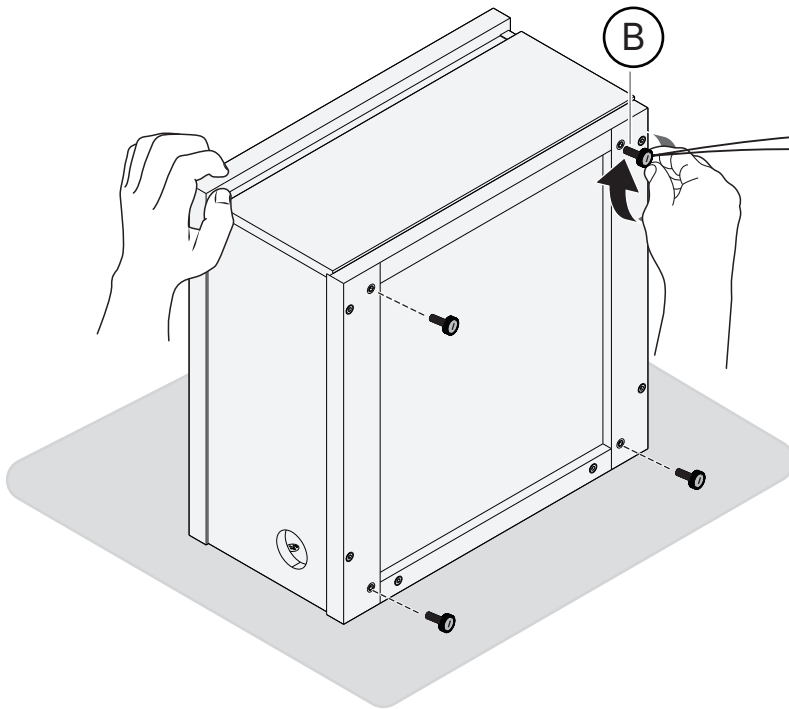

Apriete completamente todas las patas niveladoras y asegure que estén ajustadas a la misma altura.

1B Si la unidad se va a colocar en la parte superior de otro gabinete, realice la instalación de las almohadillas de parachoques.

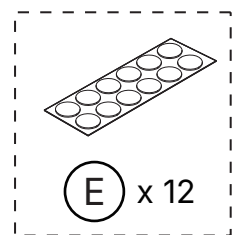
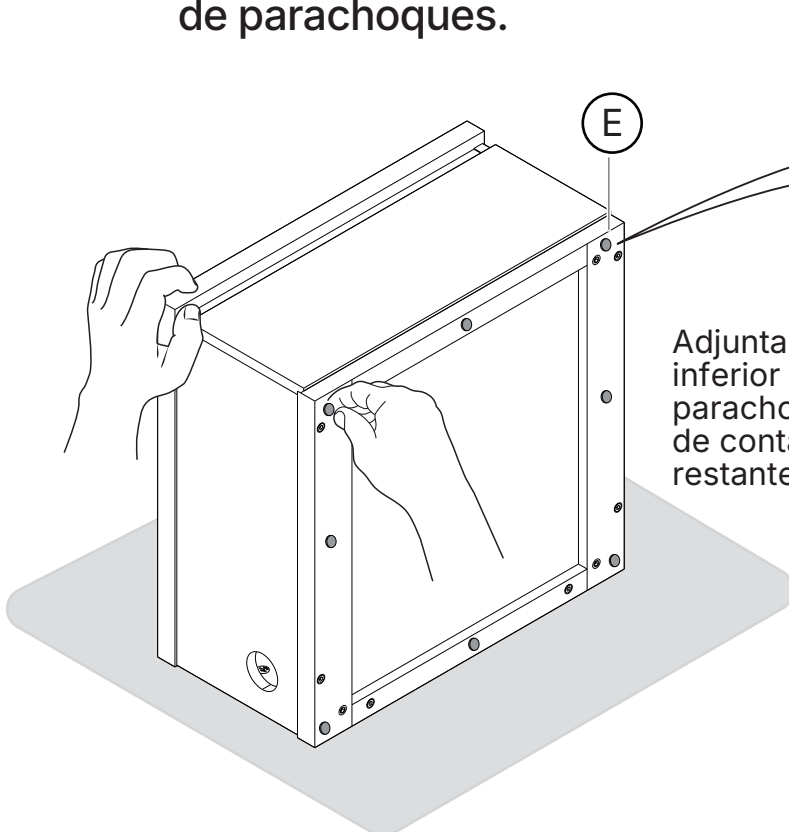

Adjuntar 8 almohadillas de parachoques a la parte inferior del gabinete. Adjuntar 2 almohadillas de parachoques al marco del gabinete en los puntos de contacto del cajón. Guardar las almohadillas restantes para uso futuro.

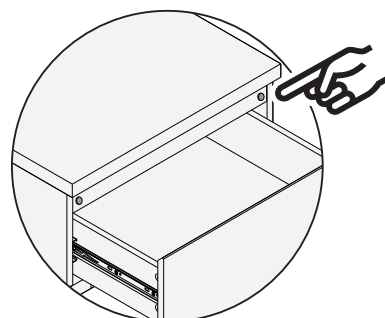

2

Instalación del Conector lateral para Instalación lado a lado (Opcional)

Antes de instalar el conector lateral, presione la pestaña de un lado hacia abajo y la pestaña del otro lado hacia arriba al mismo tiempo para quitar el cajón.

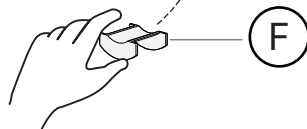
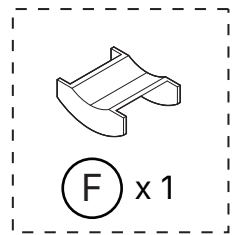
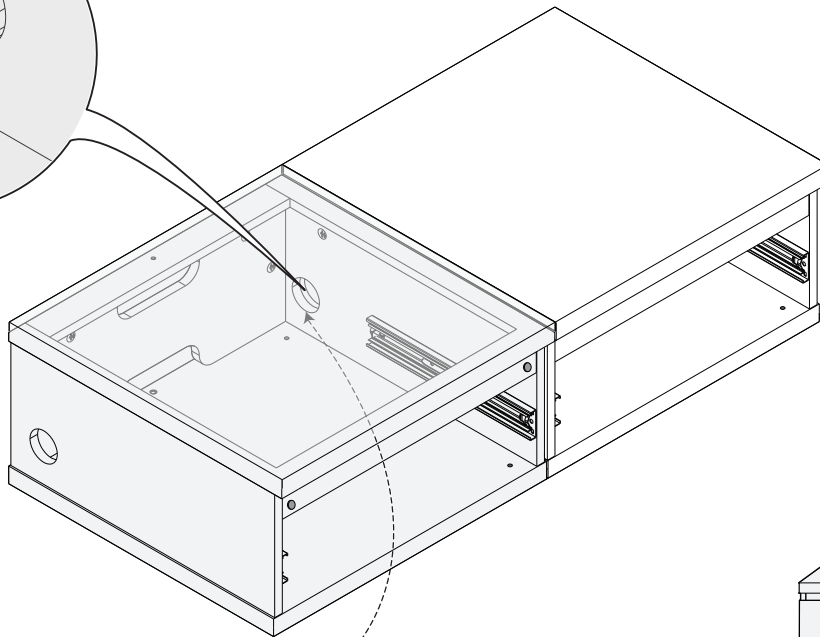
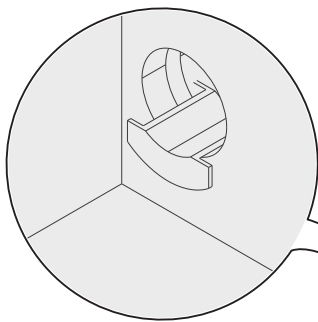
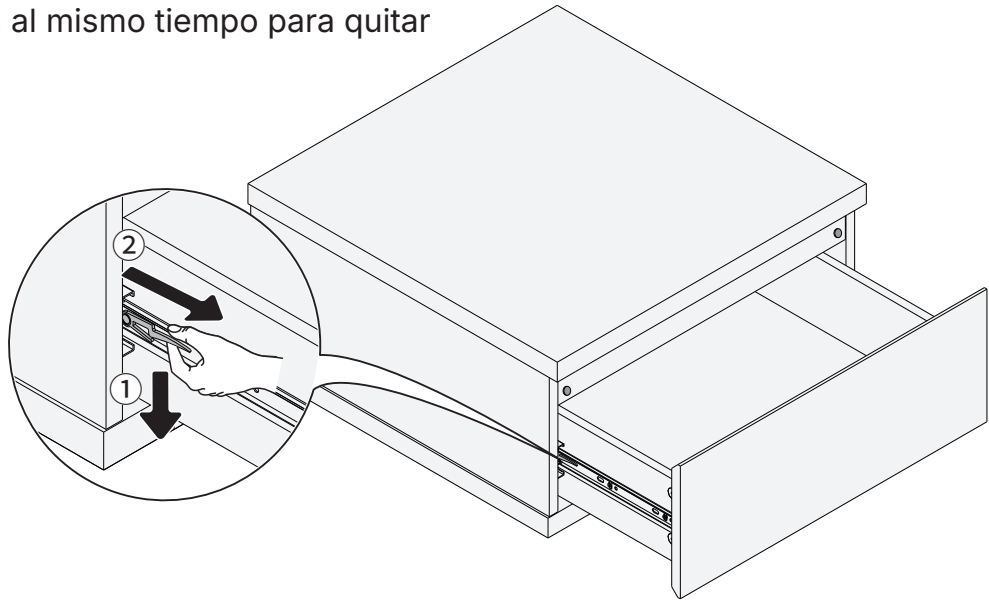

3

Instalación del Conector de apilamiento para la Instalación de apilamiento (Opcional)

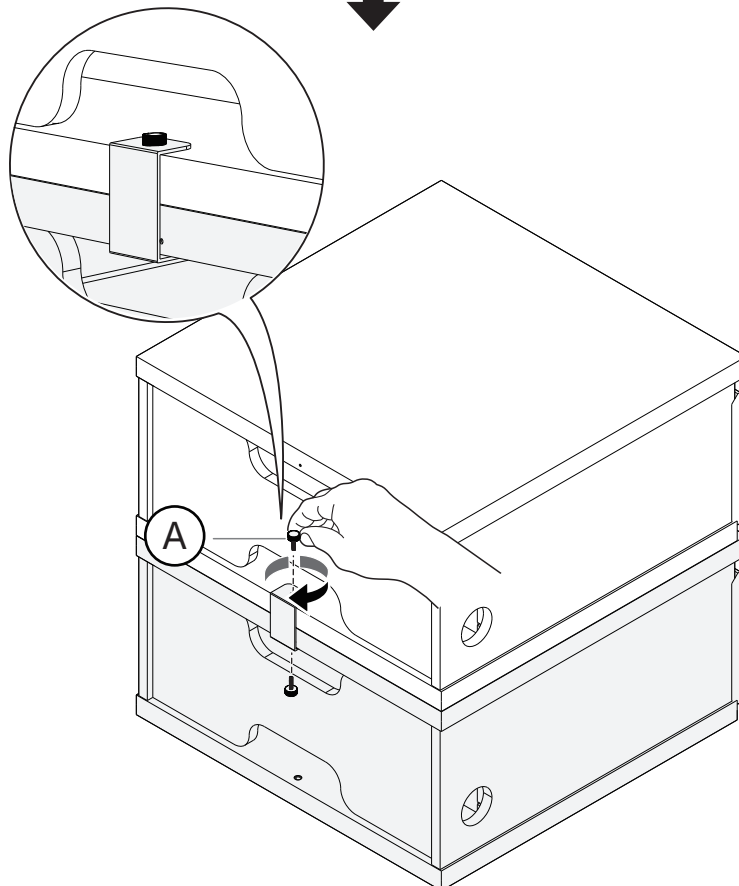
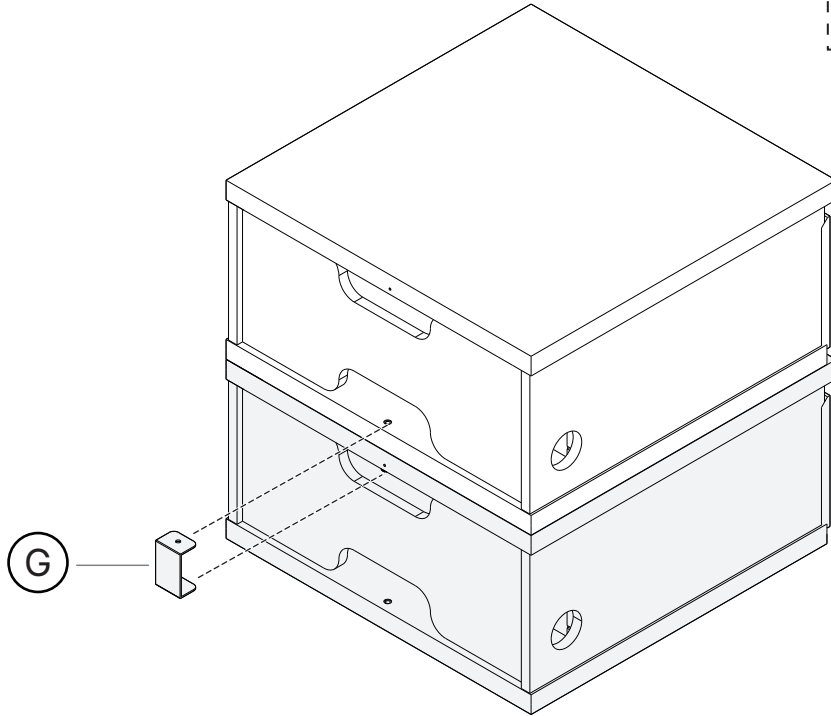
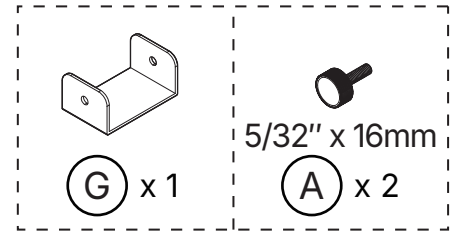

4

Instalación de la Correa Anti-propinas

1. Asegure la correa a la parte posterior de la unidad utilizando un tornillo corto y una arandela.
2. Determinar dónde se va a colocar la unidad. Si tiene una pared de montantes de madera, localizar un montante usando un buscador de montantes y hacer una marca en la línea central.
3. Perforar agujeros piloto en la pared a la altura adecuada.
4. Seguro la correa a la pared usando tornillo largo y arandela. Uso anclaje de pared para concreto sólido. No lo use en montantes de madera.

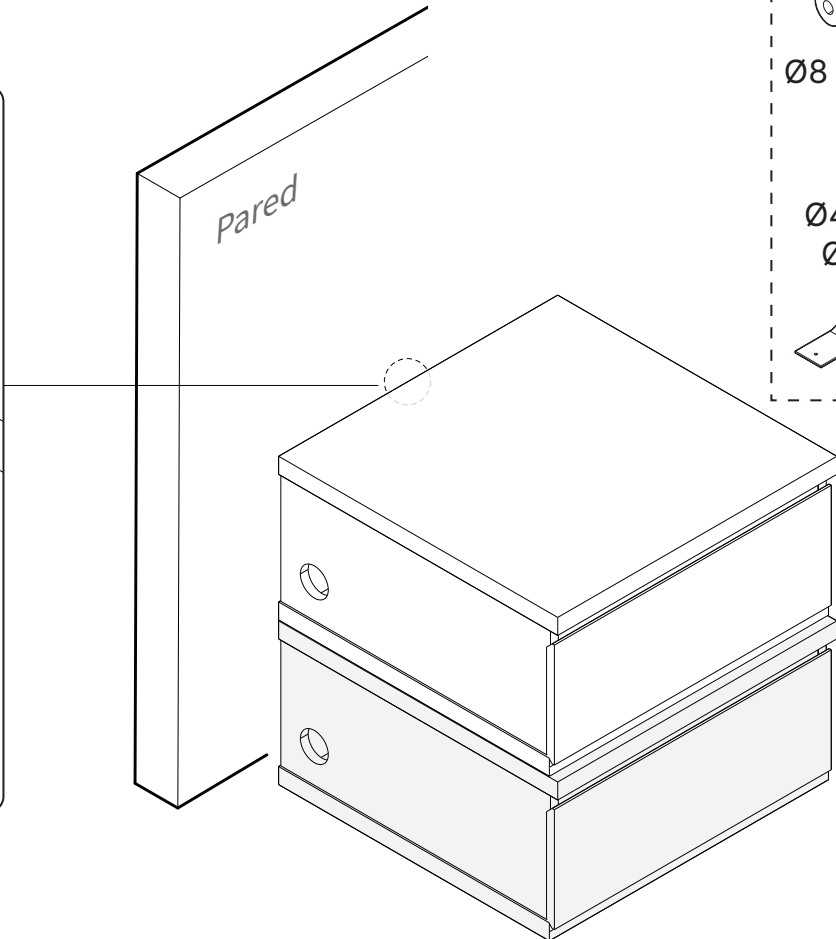
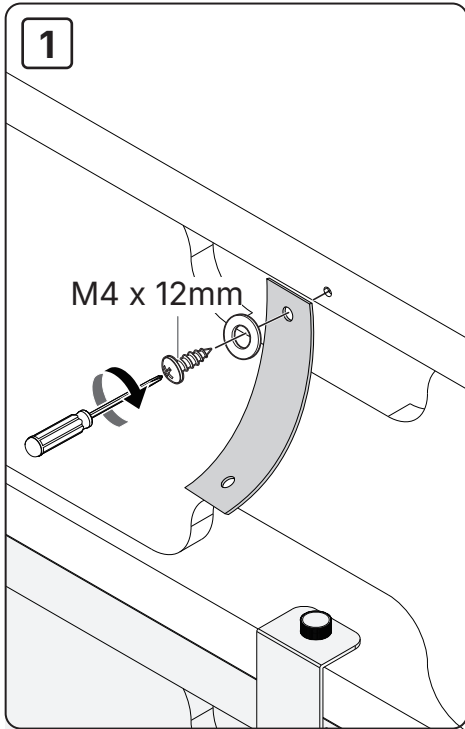
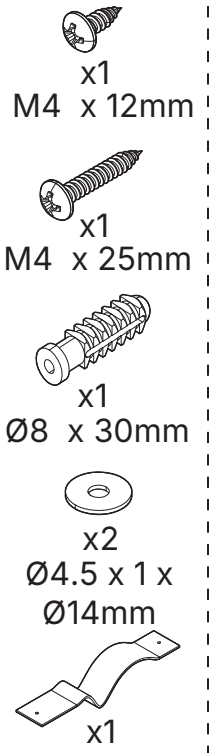

2 **Consejo:** Al realizar la marca de los agujeros en la pared, intentar alinear estos con los agujeros en la parte superior de la unidad.

A. Montantes de madera

M4 x 25mm

B. Concreto sólido

M4 x 25mm

Instalación de pasacables (Opcional)

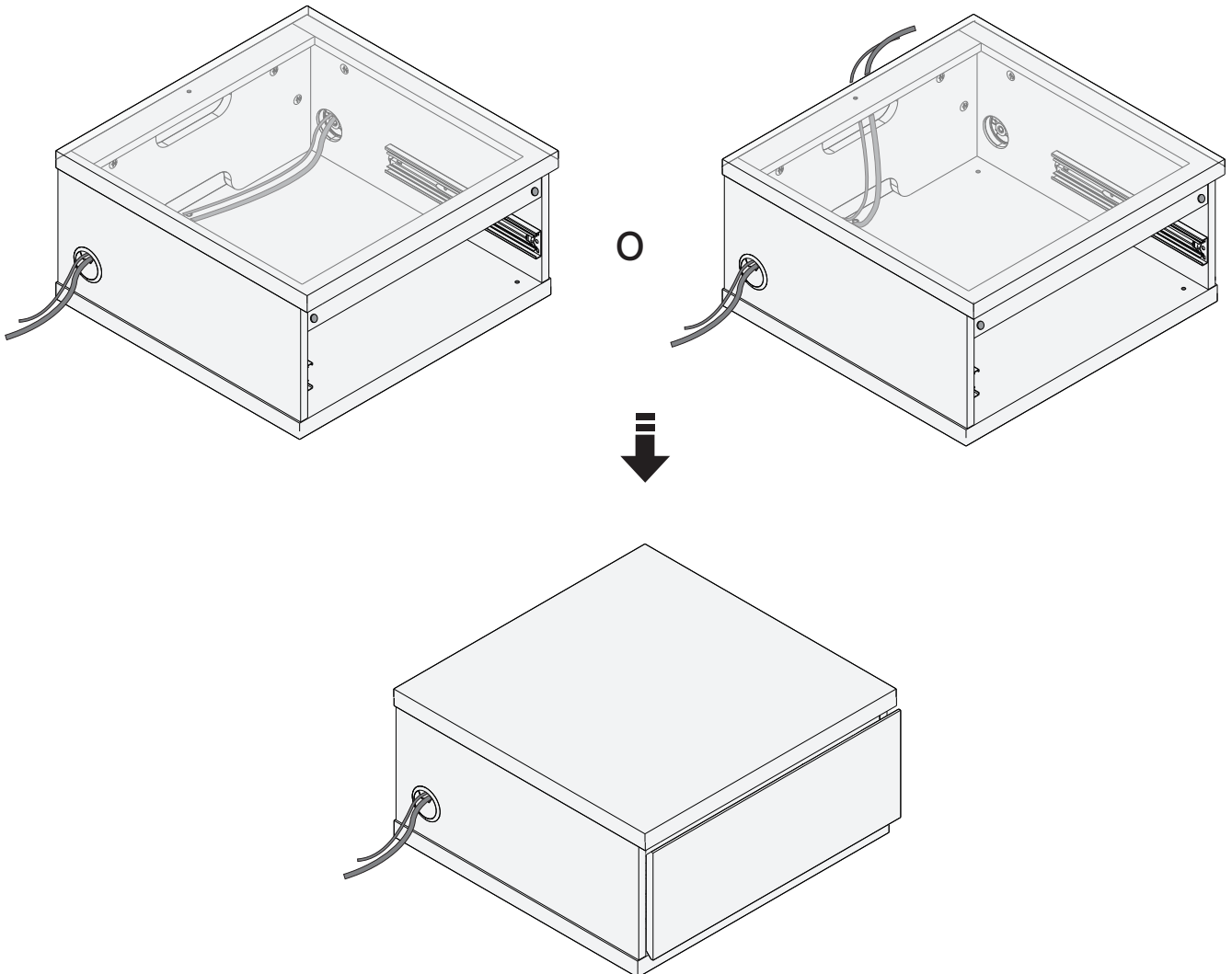
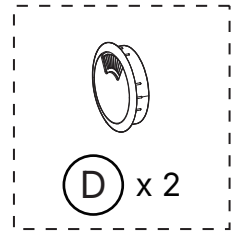
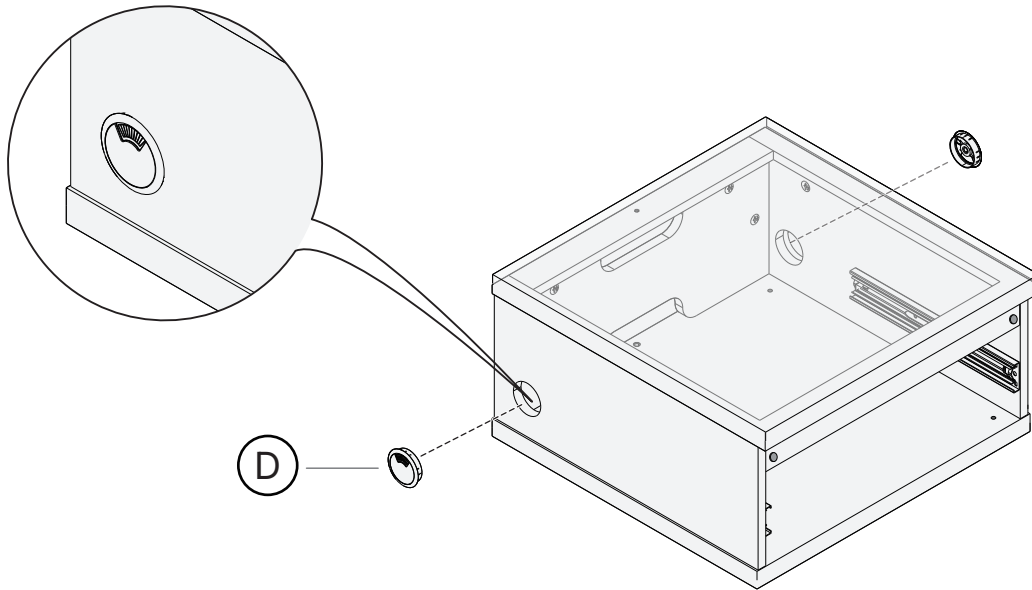

Ajuste de nivel

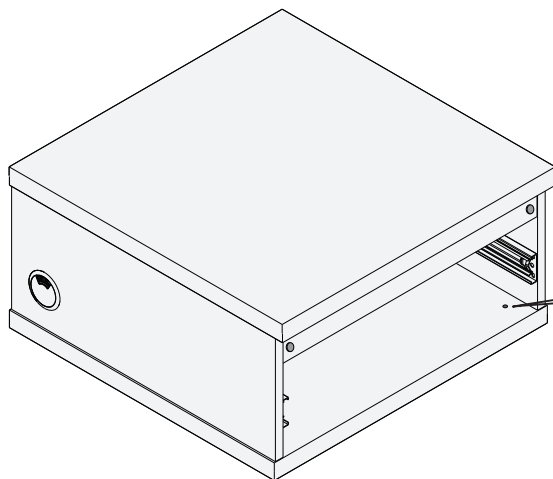

Ajuster con precisión la altura de cualquier ajuste las patas niveladoras hasta que quede nivelado.

Posibles Configuraciones

Si tiene gabinetes modulares adicionales de ErgoAV, puede combinarlos en varias configuraciones, como se muestra a continuación.

⚠ ADVERTENCIA: Niños han muerto por el vuelco de muebles. Para reducir el riesgo de vuelco de muebles:

- SIEMPRE realice la instalación del anclaje antivuelco que se debe proporcionar.
- NUNCA exceda la capacidad de peso máxima indicada en las instrucciones.
- NUNCA permitir a los niños pararse, trepar o colgar en los cajones, la puerta o los estantes.
- NUNCA abrir más de un cajón en un momento.
- Colocar los artículos más pesados en los cajones, estantes o armarios más bajos.
- No apile más de dos unidades. Cuando se apilen dos unidades, mantenga las unidades firmemente seguras usando el conector de apilado y tornillos de mariposa.
- Nunca permitir que la altura de los gabinetes apilados llegue a superar 31 pulgadas desde el piso.

Configuración A

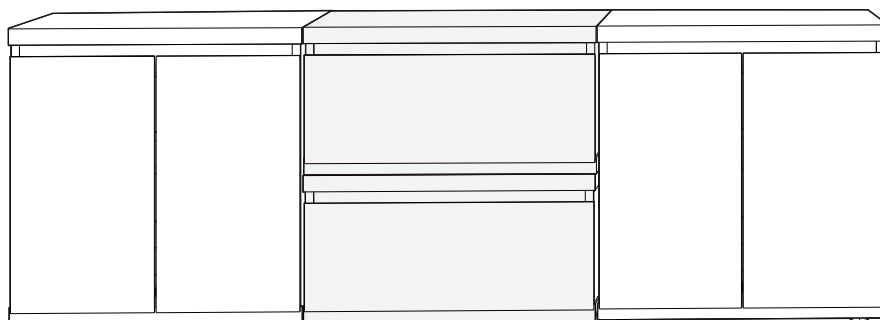

Configuración B

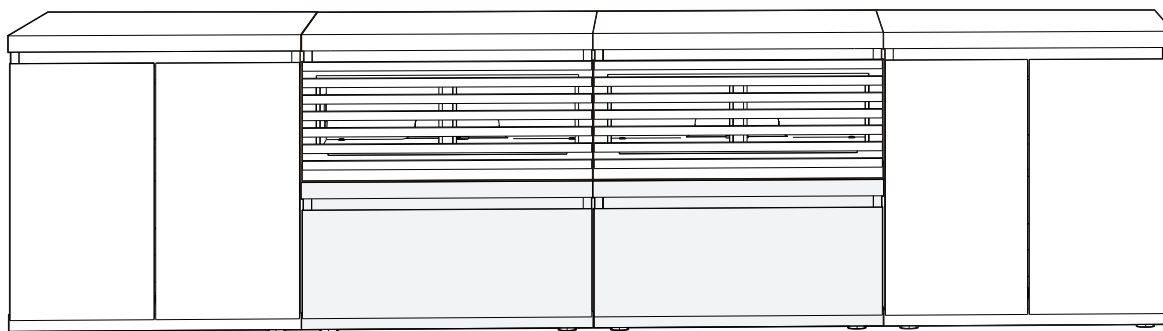

Configuración C

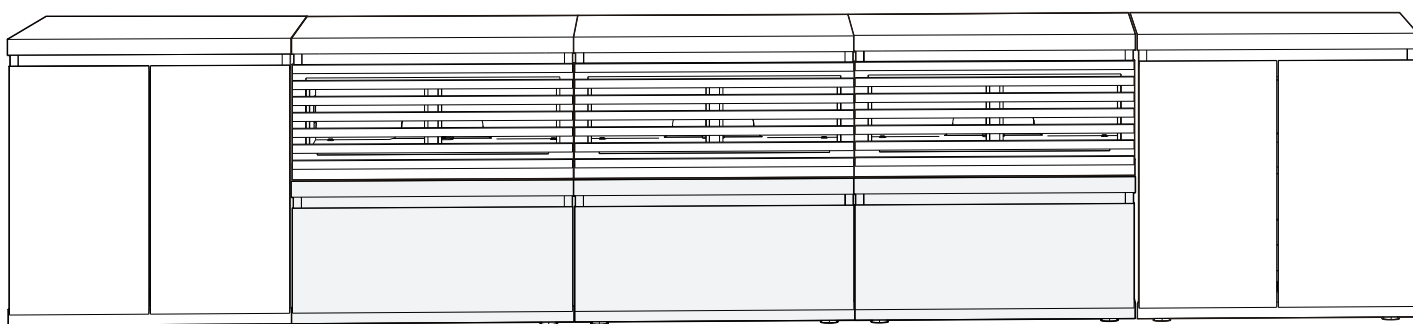

Configuración D



ERGOAV[®]

At ErgoAV, our goal is to provide the high-quality audio video solutions and product support that you need. If you have any questions, concerns, or feedback, please let us know!

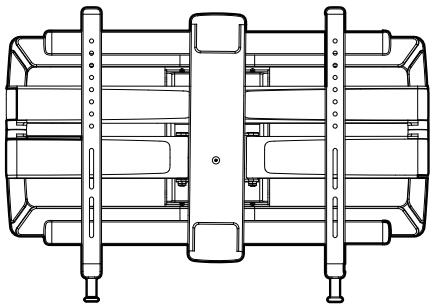

TV Mounts

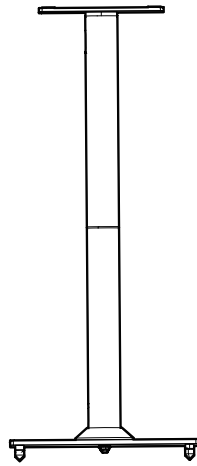

Speaker Stands

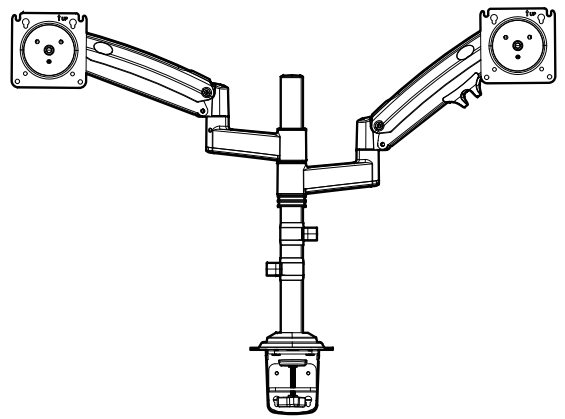

Computer Monitor Mounts

 (877) 419-7832 Mon-Fri 8am - 8pm (CST)

 support@ergoav.com

 www.ergoav.com

 ErgoAV

 9501 Louisiana Ave N, #200, Brooklyn Park, MN 55445